

Aquafil Pulse Junior 1200BF

Drinking Fountain and Bottle Refill Station

SKU: AQ-PJ1200BF

Stainless steel, hygienic and junior-friendly drinking water station with two bottle refill points and a fountain. Customisable, vandal-resistant signage panels allow for educational or brand messages to be featured on the exterior.

Ideal for indoor and outdoor settings, including schools, pre-schools, and other educational facilities.

Key Inclusions

- Two Water Bottle Refill Points (AS1428.2 1992 Compliant)
- Drinking Fountain
- Stainless Steel Construction
- Stainless Steel Buttons
- Custom Art Panels
- UV and Anti-Graffiti Protection

Customisation Options

- Soft or VR Mouthguard
- Filter
- Indoor or Outdoor Remote Chiller
- Water Meter
- Thermal Plumbing Insulation
- Frost Protection Device



Technical Details

Housing Frame	Stainless steel
Housing Unit	Anodised aluminium
Graphic Panels	Stainless steel
Filter Unit Position	Sub-micron or 5 micron
Filter Unit Working Pressure	10-125 psi (0.7-8.5 bar), non-shock
Water Supply Connections	1/2" supply line with 1/2" male BSP connection
Drainage	40mm PVC
Shipping Dimensions	132 x 190 x 70cm
Shipping Weight	45kg

Specification Text

Aquafil Indoor or Outdoor Drinking Water Station - 1205H x 359W x 585D. Complete with a drinking fountain and two AS1428.2 1992 compliant wheelchair-accessible bottle fillers on both sides. Full stainless-steel construction with UV and anti-graffiti protected interchangeable custom graphic panels. Optional filter, chiller, thermal plumbing insulation, frost protection device, installation and maintenance package. Product Code AQ-PJ1200BF.

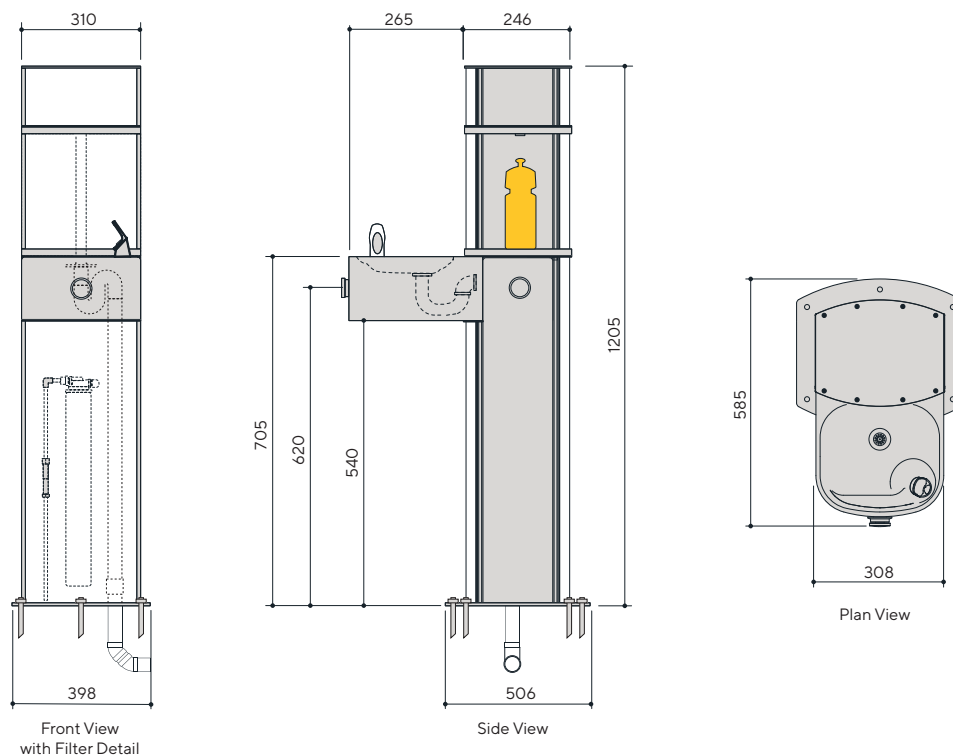

Visit civiq.com.au to access the most recent data, CAD files and installation instructions.