

Company profile

Perfect vision. **Personal touch**





Facts &
figures



A leading innovator

in ophthalmic lens technologies, and a top manufacturer of high quality progressive and single vision lens solutions

~ 2,500

Employees worldwide

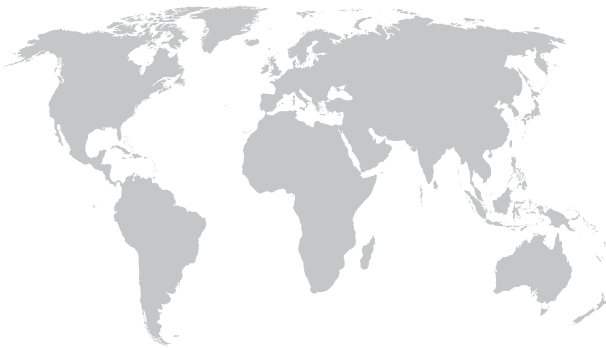

Global reach

Marketing operations in more than 20 countries

Circa

20

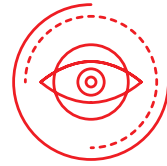

production labs

(including eight InoTime™ processing facilities) globally

284 \$M

globally in sales (2019)





The gift of perfect vision

Sight is by far one the most important human senses, with the majority of our perception conveyed by the eyes, and the brain devoting more space to handling visual input than to all other senses combined.

Many born with perfect vision may take it for granted, yet nearly two thirds of the world's population – that's approximately 4.5 billion people - suffer from some form of vision impairment.

Can you imagine being among those not able to clearly see their loved ones, read critical reporting, or otherwise perform due to poor eyesight?



Perceptiveness,
pioneering spirit and
a panoramic vision
solution offering





At Shamir, we believe everyone is entitled to perfect vision – and that’s exactly what our unparalleled lens technologies and products are designed to deliver.

Established in 1972 to manufacture bifocal lenses, Shamir Optical Industry is a leading producer of advanced single vision and progressive lenses. Over nearly five decades, the company has successfully solidified its global market position as a truly cutting-edge innovator, with the highest of quality assurance standards.

We have built our reputation on our perceptiveness to human vision challenges and pain points, and on our creativity and success in pioneering powerful vision technologies that can help overcome them. We ultimately pride ourselves on our truly panoramic product offering, which harnesses these technologies to address an unparalleled range of human vision needs.

A product of the Israeli “startup nation”, we prioritise and invest heavily in research and development, employ the very best minds in the industry, and have achieved numerous scientific and development breakthroughs that have placed us right at the forefront of optical technology. Our R&D efforts exceed in the development of visual acuity enhancing technologies, and additionally focus on supporting ECPs (Eye Care Professionals) with the products, knowledge, and tools they require to enhance their brand and grow their business.

Shamir is known for revolutionising customer experience with advanced and highly reliable manufacturing techniques, such as our groundbreaking InoTime rapid delivery solution, which enables fulfillment of prescription lenses within mere hours of orders being placed.

We’re here to help both ECPs and consumers find the right Shamir Optical Industry product to suit their needs.



A comprehensive product portfolio

Our goal is to drive our ECP customers' success with industry leading products and innovative optical solutions, all globally backed by the closest personal support.

Our state-of-the-art, worldwide award-winning Autograph Intelligence™ lenses represent a true revolution in intelligent vision design. Incorporating technology leveraging artificial intelligence to accurately model Big Data collected on actual eyeglass wearers' head and eye movements, they are designed to optimally accommodate any age or usage-driven need.

Our deep understanding and desire to address basic human requirements is clearly reflected in our truly diverse range of age and task-specific clear and sunglass lenses, which make reading, computer, and handheld digital device use, sports and urban life, among others, easier and more comfortable than ever.





From groundbreaking optometric measurement solutions, through a broad range of life improvement, fashion, performance sports, and occupational single vision and progressive lenses, and all the way to the most advanced aesthetic and protective coatings – Shamir’s staggering selection of high quality products has you fully covered.



Our technology leadership mission

Shamir prides itself on being at the forefront of optical technology, with our R&D mission dedicated to peerless service, product and technological excellence.



01

Remaining ever perceptive to customers' visual needs

Our primary goal is, and always has been, to resolve vision and related human challenges. We will therefore always listen to, and do our best to fully understand and adapt to continuously evolving consumer and ECP needs.

02

Raising the bar with pioneering spirit

We have a strong passion for innovation, and for leveraging our ingenuity and versatility to continuously come up with the "next big thing". It's in our DNA to challenge the status quo and produce breakthrough technologies that can literally bring about a quantum leap in ophthalmic lens capabilities.

03

Maintaining a truly panoramic portfolio of perfect vision offerings, backed by unparalleled service excellence

We've built our reputation on delivering and continuously expanding the most comprehensive range of industry leading products optimally addressing any and all vision needs.





Groundbreaking technologies

We are the recognised world leader in custom-designed lens technology that ensures both wearer comfort and optimised visual acuity for virtually any prescription, in any shape frame.



Eye-point Technology AI™

Advanced, artificial intelligence and head and eye motion Big Data-based vision modeling technology, enabling production of the most precisely personalised progressive lenses.



Continuous Design Technology™

Technology facilitating development of multi-concept lens designs accommodating twelve unique age ranges, and enabling provision and rapid adaptation of lenses, optimally matched to both the current and evolving needs of eyeglass wearers of any age.



Eye-point Technology III™

Precise measurement, prescription, and simulation-based personalisation technology enabling delivery of lenses with wide, distortion-free viewing fields and the most natural viewing postures, accommodating the increasing use of handheld digital devices.



Visual AI Engine™

Automated and significantly accelerated development and personalisation technology enabling continuous, first-to-market provision, of lenses most precisely tailored to the needs of numerous predefined visual age ranges.



Natural Posture™

Technology enabling delivery of ergonomic lens designs ensuring the most comfortable viewing postures, specifically when reading and viewing nearby objects.



As-worn Quadro™

Technology ensuring measurement and prescription-faithful visual experience in any frame of choice, with greatly reduced sensitivity to frame tilt variations.



Intellicorridor™

Technology facilitating precise power control along the entire eye convergence path, for production of lenses that optimally accommodate intermediate vision-dependent tasks, support digital device users without compromising far vision, and ensure smooth transition among all vision zones.



Close-up™

Lens personalisation technology ensuring maximum visual comfort in near and intermediate zones, via precise accommodation of the physiological properties of individual eyeglass wearers' eyes, and of their natural focusing motions.

Global presence

Our worldwide reach, extending across Europe, America, Asia Pacific, Africa and the Middle East provides the close proximity required to best support ECPs and customers in their own countries. It also grants our entire organisation and ECP customer base a uniquely global perspective. It serves as a basis for beneficial regional cooperations and a truly local focus, both of which make it possible for us to optimally adapt our product offerings to the needs and requirements of specific geographies and – most importantly – individual customers.

- Management and R&D headquarters
- 22 Shamir subsidiaries
- 10 optical labs
- 2 production sites
- 8 InoTime facilities





Local knowledge

When it comes to Australian Made spectacle lenses, Shamir sits at the pinnacle of the industry. Shamir Optical Industry has been a certified Australian Made company since 2014, utilising its internationally renowned technology, research, and design to manufacture industry-leading products from the Shamir Australia Laboratory based in Brisbane.

We are recognised for our high quality products and have helped to enhance the vision of lens wearers Australia wide.



Lenses ▶



Our
partnership



Our message to eye care professionals is loud and clear. We see you, and are here to help you compete and grow your business in an increasingly challenging market landscape.

While excellent products are naturally a must-have, to us, there's unquestionable beauty in the highest quality service, too. We're set to provide every bit of training, education, and support you need to deliver the best possible visual solutions and experiences to your customers.

After all, your business goals are equally ours. We'll share the knowledge and expertise you need to overcome challenges, minimise customer non-adapts and increase sales.

Each and every one of our representatives is personally committed to your vision, and will provide the service and support required to make it happen.





The Shamir Academy's training and educational learning platforms offer commercial training and skills to develop business opportunities, product strategy, and profitability.

Shamir Academy offers technical and commercial training, from product insight to effective dispensing tips, as well as a continued learning cycle designed to help your practice continue to grow.

Tour our Brisbane offices, laboratory, and work facilities. Experience the Shamir manufacturing process. Learn through purpose built presentations and workshops in Shamir's dedicated meeting and training rooms.



Shamir Academy

- Business development programs and benchmarking based on practice data and goals.
- Assisted strategies to increase sales and profitability.
- Information on world leading Shamir lenses and coating technologies.
- Dispensing techniques and troubleshooting.
- Commercial training and skills to develop business opportunities and profitable management.
- Methods to develop staff sales skills.

TECHNOLOGIES

- Eye-point Technology AI™
- Eye-point Technology III™
- Continuous Design Technology™
- Visual AI Engine™
- Natural Posture™
- Intellicorridor™
- As-worn Quadro™
- Close-up™

PROGRESSIVE LENSES

- Shamir Autograph Intelligence™
- Shamir Autograph IIID™
- Shamir Autograph InTouch UX™
- Shamir Autograph Urban™
- Shamir Autograph Spectrum™
- Shamir Autograph Spectrum+™
- Shamir Autograph Driver Intelligence™
- Shamir Attitude III Sport™
- Shamir Attitude III Fashion™

SINGLE VISION LENSES

- Shamir Smart SV III As-worn™
- Shamir Relax™
- Shamir Attitude III SV™

OCCUPATIONAL LENSES

- Shamir Computer™/Workspace™
- Shamir Smart Office™
- Shamir Vocational Digital™

BIFOCAL LENSES

- Shamir Duo™

Technologies

Shamir leads the way with a range of breakthrough technologies enabling design of advanced lenses that ideally address a broad range of human visual needs.

Eye-point Technology AI™

Eye-point Technology III™

Continuous Design Technology™

Visual AI Engine™

Natural Posture™

Intellicorridor™

As-worn Quadro™

Close-up™



Eye-point Technology AI™



Groundbreaking head and eye motion-based vision modeling technology

Eye-point Technology AI™ is Shamir's premium lens design technology. It goes beyond traditional measurements and simulations, and incorporates artificial intelligence to accurately model Big Data collected on actual eyeglass wearers' head and eye movements, as part of the lens design process.

The technology allows Shamir's lens developers to precisely predict and accommodate exactly where and how eyeglass wearers of different ages gaze through their lenses – across both vertical and horizontal meridians – so as to optimally assist them in the diverse tasks they need to perform under varying circumstances.

Main benefit

The ability to produce the most advanced and precisely personalised progressive lenses that deliver an optimal visual experience for any age and usage-driven requirement.





Eye-point Technology III™

Precise measurement and simulation-based lens personalisation technology

Eye-point III™ is technology enabling delivery of personalised lenses with wide, distortion-free viewing fields, standardised for both hyperopic (farsighted) and myopic (nearsighted) eyeglass wearers.

Relying on precise measurements and prescriptions, and on simulation of perceived, real-world viewing fields, the technology enables lens designers to achieve precise power profile control, and apply specific power emphasis at different points and vision zones across lens surfaces.

Main benefit

The ability to produce lenses enabling eyeglass wearers with any prescription and frame choice to achieve a clear and comfortable visual experience, while ensuring the most natural viewing postures and accommodating the increasing use of handheld digital devices.



Continuous Design Technology™

Technology enabling delivery of multi-concept lens designs, improving the vision of eyeglass wearers of any age

Continuous Design Technology™ is Shamir's way of most efficiently and effectively delivering different lens designs that accommodate eyeglass wearers of different ages and visual needs.

Rather than serve eyeglass wearers of all ages and usage patterns with one and the same lens design, the technology enables Shamir designers to deliver a single concept encompassing twelve unique designs, each tailored exactly to the needs of one of twelve pre-established age ranges.

Main benefit

The capability to provide and very rapidly adapt different lenses, optimally matching both current and evolving needs, and ensuring an easy transition to eyeglass wearers' next lenses in line as they age.



Visual AI Engine™

Technology for automation and significant acceleration of personalised lens development

Shamir's Visual AI Engine™ is a Big Data and artificial intelligence-driven lens design technology. Our Continuous Design approach enables Shamir lens designers to establish and deliver twelve unique lens variations within a single concept, all tailored precisely to the needs and usage habits of twelve specific age ranges.

Developing a large number of variants from prototype to final design would normally require a vast amount of time. However, with Visual AI Engine™'s autonomous optimisation of spheres, addition powers, face-form angles, pantoscopic tilts, fitting heights, base curves, indexes and more, and its automated self-checks, our developers are able to dramatically accelerate this process and cut down lens development time by years.

Main benefit

The ability to continuously be first-to-market with the most advanced lenses, designed with the greatest accuracy to match the needs of a range of different visual ages.





Natural Posture™

Technology enabling delivery of ergonomic lens designs for the most comfortable viewing postures

Natural Posture™ is an innovative ergonomic design technology enabling development of lenses that optimally accommodate eyeglass wearers' head posture when reading or focusing on nearby objects.

The technology enables Shamir developers to dynamically position near viewing zones on lens corridors, while precisely adhering to prescribed positive or negative power profiles, so as to optimize vertical head and eye motion and ensure maximum viewing comfort in these zones.

Main benefit

The ability to produce lenses that maximise individual postural comfort when reading and viewing nearby objects, while minimising the need to raise or lower items, or tilt one's head up or down – ideal for anisometropic eyeglass wearers, whose eyes focus unevenly and who require varying accommodative eye support.





Intellicorridor™

Technology allowing precise power control for clear vision along the entire eye convergence path

Intellicorridor™ is technology enabling strict control over power profiles implemented along the eye's visual path across a progressive lens' vertical meridian, or corridor.

The technology grants Shamir lens developers full control in optimally applying variable power emphasis to any number of eye convergence points and vision zones on the lens surface. It additionally enables provision of dedicated support for modern lifestyle near vision tasks, such as frequent use of tablets and smartphones.

Main benefit

The ability to produce lenses that optimally accommodate a range of common intermediate vision-dependent tasks and activities, enable easy adaptation for digital device users without compromising far vision, and ensure smooth transition among all vision zones.



As-worn Quadro™

Technology ensuring optometrist measurement-faithful visual experience in any frame of choice

As-worn Quadro™ technology enables Shamir lens developers to ensure that the exact same visual clarity and comfort eyeglass wearers experience with trial frames on conclusion of optometrist eyesight measurements is maintained when their new lenses are fitted into their frames of choice.

The technology facilitates precision personalisation and customisation of lenses to specific frame shapes and tilt angles, and to their distance from wearers' eyes. It ultimately ensures that the right power corrections established to be required in ECP measurements are maintained without compromising an eyeglass wearers' own frame of choice.

Main benefit

The ability to produce lenses with greatly reduced sensitivity to frame tilt variations, that deliver enhanced visual performance in any chosen frame.



Close-up™

Lens personalisation technology ensuring maximum near and intermediate visual comfort

Shamir's Close-up™ technology allows adjustment and precise correlation of lens reading and intermediate vision zone insets to individual eyeglass wearers' specific eye convergence or divergence, as well as to the distance between their pupils, the length of their arms, their lifestyles, work habits and more. This ultimately enables delivery of the perfect balance between visual clarity and ergonomic comfort.

Main benefit

The ability to deliver lenses that fully accommodate natural eye focusing motions, ensure near and intermediate vision clarity, and maximise viewing comfort by precisely matching the specific physiological properties of individual eyeglass wearers' eyes.



Progressive lenses

Shamir Autograph Intelligence™

Shamir Autograph IIID™

Shamir Autograph InTouch UX™

Shamir Autograph Urban™

Shamir Spectrum™

Shamir Spectrum+™

Shamir Driver Intelligence™

Shamir Attitude III Sport™

Shamir Attitude III Fashion™

Single vision lenses

Shamir SV III As-worn™

Shamir Relax™

Shamir Attitude III SV™

Occupational lenses

Shamir Computer™ / Workspace™

Shamir Smart Office™

Vocational Digital

Bifocal lenses

Shamir Duo™

NEW RELEASE:

DESIGNED TO EVOLVE

The progressive lens that keeps evolving

Shamir's award-winning Autograph Intelligence™ is the first lens design that incorporates elements of Artificial Intelligence, based on big data. This premium design offers a unique solution, based on continuous research which provides an ongoing flow of data to update the lens design to the changing needs of wearers.

The Result? A superior lens that optimally matches a person's visual age with their visual needs.



Optimal user experience

Easy entry and quick adaptation to progressive lenses



New: significantly enhanced digital support

for any virtual application, for eyeglass wearers of any age



Tailored for balanced visual performance

For any visual need with any Visual Age

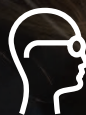

High precision personalisation

Constant input of latest scientific data, with Artificial Intelligence analysis

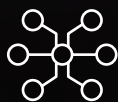

over

500,000

bits of data



from over

6,000

people of varying ages & occupations



Located in

6

different countries

WHAT WE DISCOVERED

Behaviors are changing across the board.

Most importantly, there has been a rapidly growing shift from the physical to the virtual, meaning that now more people, at every age, are spending more time using digital screens.

This tremendously impacts visual behavior and needs, in distinct ways and at specific ages. Work, studies, shopping, and even leisure and sports activities are increasingly moving to digital platforms. Today's progressive lenses must address this issue, with sensitivity to Visual Age.

60%



Increase in Digital Use

(Computer, Tablet, Smartphone)
On average, compared to 2017, cross all age groups, based on Shamir's research.



13+

Hours a Day

Viewing digital screens since the emergence of COVID-19. (Mary Kane, Vision Council 03.2021)

60%

of respondents reported **eye strain**

in a 2020 poll

* Alcon/IPSOS Poll.



Shift-To-Digital

Brings visual & ergonomic challenges - Eye pain and fatigue, headaches, neck and shoulder pain, and more.

The artificial intelligence-driven lens of the future made available today

What it is

The first progressive lens of its kind, optimally tailored to individual eyeglass wearers' needs and visual age (the physiological age of one's eyes) via AI (Artificial Intelligence). Shamir Autograph Intelligence™ achieves this highest precision match via extensive research of consumer preferences and age-specific use of different vision zones, and implementation of innovative Big Data and AI-assisted lens design.

Autograph Intelligence™ overcomes the limitations of traditional progressive lenses, which feature identical concepts for all ages and addition powers, with the most precisely personalised lens designs. It utilises the power of AI to deliver twelve unique and innovative progressive lens concepts, each carefully tailored to the needs of specific visual ages and zone usage profiles.

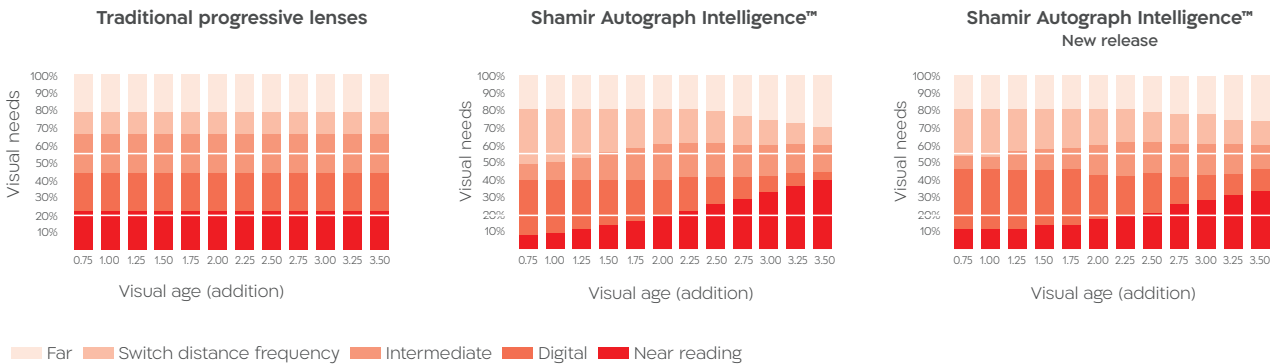

Evolution of digital/virtual application vision zone support, from standard progressives through Autograph Intelligence™ lens generations.





Who it's for

Eyeglass wearers aged 40 and up experiencing increasing difficulty reading small print, suffering from eyestrain and headaches, and demanding the most technologically advanced, most precisely personalised lenses.

Benefits

The most precise fit to age-specific visual needs and habits.

Clear and seamless (single vision lens-like) visual experience.

Seamless transition among vision zones.

Optimal visual experience with any frame of choice.

Maximum postural comfort via significant reduction of undesirable head movements.

Digital (handheld device and computer) viewing zone support.



Shamir
Autograph IIID™

A premium progressive lens for accurate and personalised detailed vision across all vision zones

Developed with the concept of precise measurement of individual prescriptions and simulation of perceived, real-world viewing fields, Shamir Autograph IIID™ delivers sharp, clear vision, with seamless gradation across all vision zones.

It adapts the lens to your customer's prescription so that whether they are near or far-sighted, they see with high visual acuity. This enables them to focus on any task throughout the day: Whether driving, cooking, playing sport, watching TV or relaxing on their laptop just before bed.

Who it's for

Eyeglass wearers with modern lifestyles, who frequently use digital devices and expect the highest visual comfort.



Featured technologies





Benefits

Individual design that maximises the vision potential for pluses and minuses

Sharp detailed vision at all visual distances

Upgraded digital vision zone with visual acuity uniquely adapted to today's needs

Ergonomics for user comfort throughout the day



Shamir
Autograph InTouch UX™

Maximising the digital experience, integrating both vision and comfort

Autograph InTouch UX™ was the first progressive lens specifically designed for digital use, ensuring convenient viewing for 30-70 centimeter digital zones and easy transition among all viewing zones.

Shamir Autograph InTouch UX™ is an upgraded version, designed to improve the total visual experience by providing sharper vision for the digital zones and by maximising individual postural comfort, for a total experience that's perfectly matched for digital devices.

Who it's for

Wearers with modern lifestyles, who frequently use digital devices and expect the highest levels of visual comfort.



Featured technologies





Benefits

Maximising the user experience for digital

Visual experience

The upgraded version improves convergence during near viewing, ensuring better sharpness for digital devices

Ergonomic experience

Maximum postural comfort via a significant reduction in undesirable head and body movements

A dynamic progressive lens for the modern urban lifestyle

What it is

A soft progressive lens that provides optimal visual clarity from the first moment it's worn, and when shifting vision between the near and intermediate vision zones characteristically focused on in fast-paced urban environments, all while fully preserving far vision integrity.

Urban environments constantly confront us with countless visual stimuli, from brightly lit billboards, storefront displays, and all the way to computers and handheld devices. This makes for an unprecedented need to maintain a seamless visual experience at close and medium distances, without compromising the ability to keep a clear view of objects further away.

The solution - Shamir Autograph Urban™, a uniquely flexible and soft lens that ideally accommodates the seamless near-to-mid-range focus shifts required in modern life.

Who it's for

First-time progressive lens eyeglass wearers aged 40 and up, requiring the ability to dynamically yet comfortably focus on objects in multiple nearby, intermediate and far vision zones.





Benefits

Instant focus and seamless transition between close and mid-range vision zones.

Unprecedented support for near zone computer and handheld digital device viewing.

Quick and easy adaptation for first-time progressive lens wearers.

An ergonomic everyday lens

What it is

Shamir Spectrum™ is an ergonomic everyday lens that delivers an improved visual experience in both near and far vision zones. It features Shamir's unique Eyepoint Technology™, which helps to provide a lens with wide, clear, near and intermediate vision.

This technology ensures an accurate design and analysis, and enables the development of sophisticated, tailor-made progressive lenses.

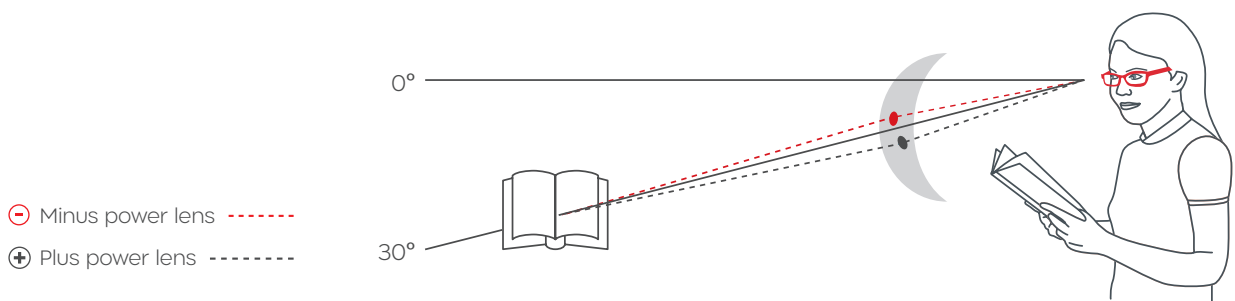

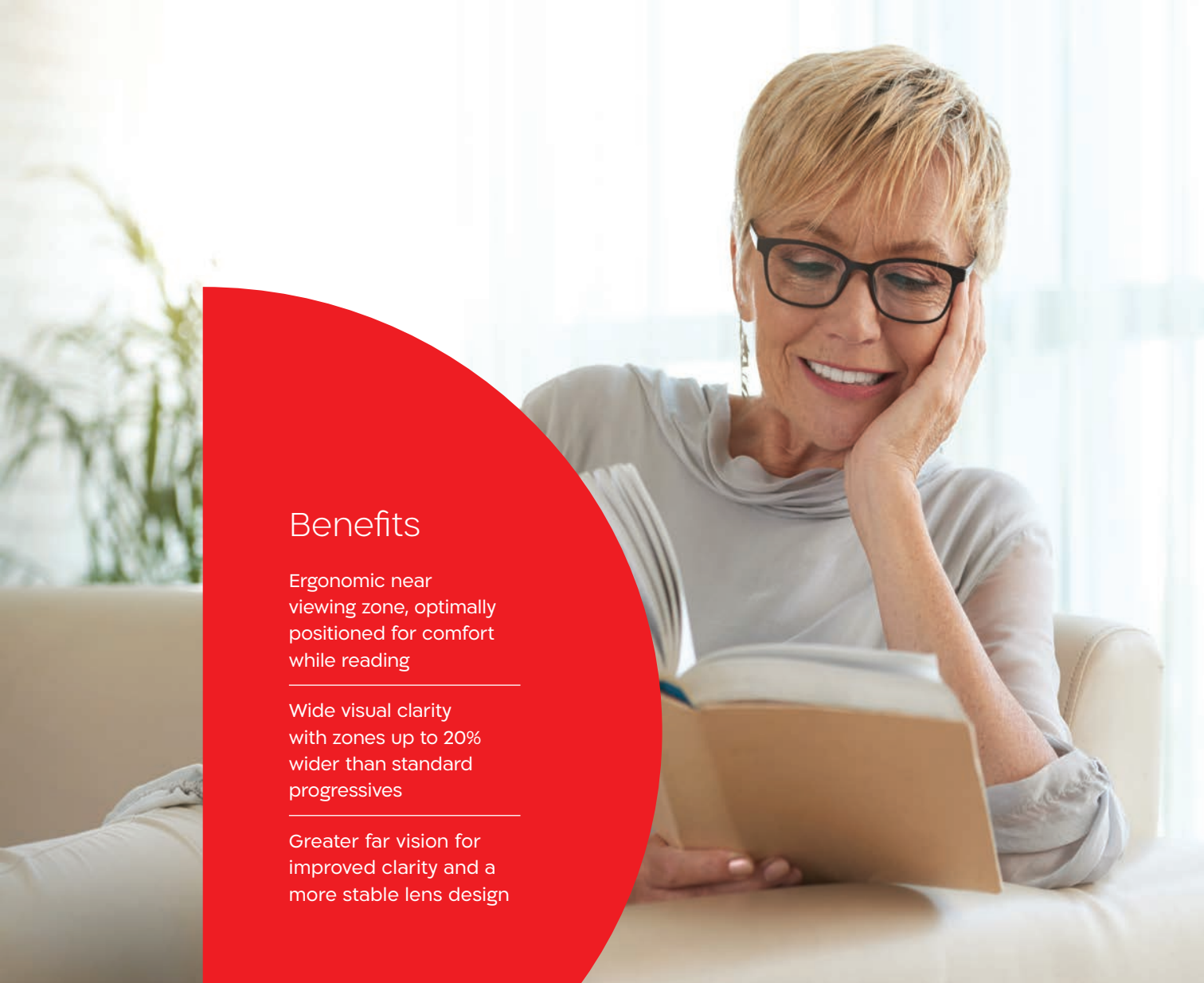

Benefits

Ergonomic near viewing zone, optimally positioned for comfort while reading

Wide visual clarity with zones up to 20% wider than standard progressives

Greater far vision for improved clarity and a more stable lens design

Who it's for

Cost-conscious wearers aged 40 and up requiring visual clarity and comfort across all zones, and specifically when reading books and focusing on nearby objects.

A powerful progressive reading lens

What it is

A progressive lens that delivers sharp and comfortable visual experience, with broad near reading zones, and strong personalisation to customers' individual reading posture.

Shamir Spectrum+™ been improved to feature Shamir's unique Natural Posture Technology™, which dynamically locates the near viewing zone, taking into account the positive or negative power of the prescription.

Any postural discomfort is minimised, sensing a comfortable natural posture for near viewing.

Shamir Spectrum+™ also features EyePoint Technology™, combining lens surface topography data with an advanced algorithm to calculate performance across thousands of locations on the lens surface. The result is a more accurate design for enhanced vision.

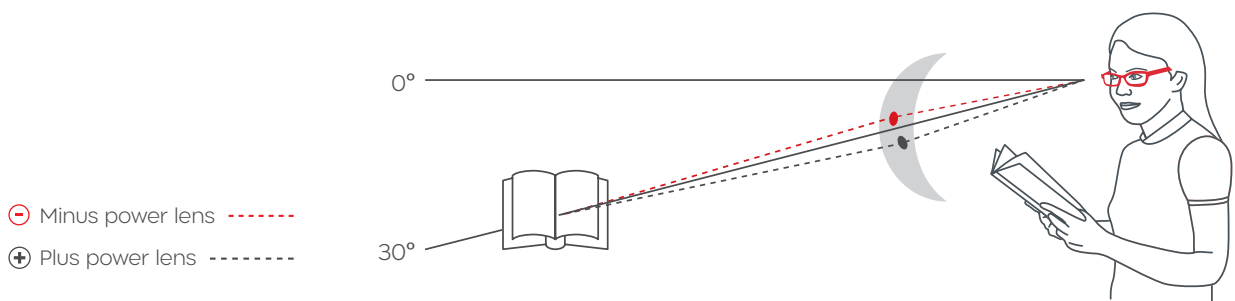

A man with a beard and glasses is shown in profile, reading a book. He is wearing a light blue polo shirt. The background is slightly blurred, showing another person's hand holding a book. A large red semi-circle is overlaid on the left side of the image, containing text.

Benefits

High near vision clarity, with viewing zones 20% broader than those of standard progressives

Unprecedented comfort, with near viewing zone optimally positioned for natural reading posture

Enhanced far vision with lens design stability by far exceeding that of traditional progressive lenses

Who it's for

Wearers requiring a general purpose lens, with enhanced support for reading and focusing on nearby objects.

A full solution for optimised driving vision lifestyles

What it is

Whether embarking on a long journey, commuting to work, or driving on the job, Shamir's Driver Intelligence™ lenses provide the clarity and comfort that drivers need, elevating the driving performance.

Shamir Driver Intelligence™ offers a set of two pairs of driving-dedicated, premium, progressive or single vision lenses - Sun for daylight driving, Moon for low-light and nighttime conditions.

Shamir Driver Intelligence™ integrates Shamir's proven lens technology and design methodology with extensive insights from pro drivers of BWT Alpine F1® Team.

The result: Groundbreaking lenses that deliver the clearest, sharpest vision, with enhanced colour contrast, enabling confident and safe driving performance.

Who it's for

All drivers who are also eyeglass wearers, including Greater Passionate and everyday drivers. Whether embarking on a long journey, commuting to work, or driving on the job, they want to experience the joy of driving with clear, sharp vision.

Featured technologies



The background of the entire page is a futuristic cityscape at night, with numerous skyscrapers illuminated with blue and white lights. Overlaid on this cityscape are several glowing blue lines and dots that form a complex, abstract pattern, resembling a network or a data visualization. In the upper right portion of the image, a large, dark, lens-like object is shown in a perspective view, appearing to float in the air. The overall color palette is dominated by deep blues, purples, and reds, creating a high-tech, digital atmosphere.

Benefits

Propelling a better driving experience*

Increased Road awareness due to higher attention

Lower cognitive load for improved visual processing

Optimal physical comfort enabling a more pleasant drive with less effort

Greater confidence under varied conditions

Faster reaction times for improved performance

* Based on research, samples, pilot analyses and actual lens design measurements conducted by Shamir

A progressive sunglass lens for sports and active lifestyles

What it is

A progressive performance sunglass lens prescription-tailored to deliver clear undistorted vision, specifically in the zones characteristically focused on by people engaged in sports or in active lifestyles.

Shamir Attitude III Sport™ delivers a distortion-free visual experience, specifically in vision zones crucial to sports and active lifestyles, while maintaining full clarity and stability even when performing sharp, rapid motions. It features an outstanding soft design and incorporates moderate power increases to ensure clear and stable vision in crucial zones, both above and below the horizon line.

The lens ultimately enables clear vision anywhere – from the near zone used to view fitness bands and smartwatches, the 1-to-5 meter “safety zone” athletes focus on to plan their next moves, and all the way to the expanded peripheral zones of curved sunglass frames.

Who it's for

Sunglass wearers aged 40 and up, who expect the best possible visual experience in sports and outdoor activities, even with curved eyeglass frames.

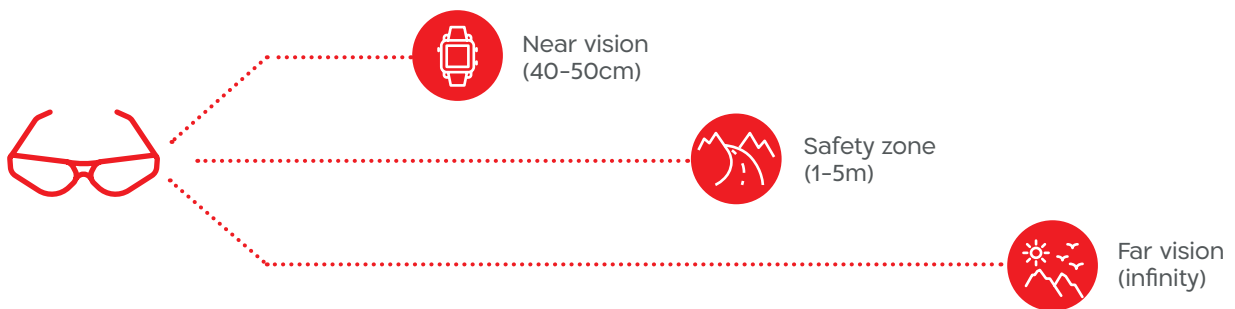

Featured technologies



Benefits

Optimal visual experience
with curved sunglass frames.

Instant focus and clear vision
in intermediate (safety), far
and peripheral vision zones,
with dedicated support for
near zone use of fitness
bands and smartwatches.

Seamless transition among
vision zones.



A progressive sunglass lens for any fashion frame

What it is

A progressive sunglass lens precisely tailored to the individual prescriptions and dynamic vision zones of customers engaged in a modern lifestyle, ensuring clear, undistorted visual experience outdoors in sunglass frames of any size and curvature.

Shamir Attitude III Fashion™ delivers a clear and distortion-free, prescription-personalised visual experience, specifically in far vision zones with an expanded peripheral viewing field across even the largest of curved frames. The lens additionally covers the intermediate vision zones required in modern lifestyles involving frequent use of digital devices, and helps reduce the need to tilt one's head forward or back, or lower or raise nearby objects to achieve convenient viewing.

Who it's for

Sunglass wearers aged 40 and up, wishing to enjoy the widest and most distortion-free vision outdoors, even with large and curved sunglass frames.

Featured technologies





Benefits

Optimal visual experience, even with large and curved fashion sunglass frame designs.

Instant focus and clear vision in intermediate, far and peripheral vision zones, with dedicated support for near zone use of handheld digital devices.

Seamless transition among vision zones.

Progressive lenses

Shamir Autograph Intelligence™

Shamir Autograph IIID™

Shamir Autograph InTouch UX™

Shamir Autograph Urban™

Shamir Spectrum™

Shamir Spectrum+™

Shamir Driver Intelligence™

Shamir Attitude III Sport™

Shamir Attitude III Fashion™

Single vision lenses

Shamir SV III As-worn™

Shamir Relax™

Shamir Attitude III SV™

Occupational lenses

Shamir Computer™ / Workspace™

Shamir Smart Office™

Vocational Digital

Bifocal lenses

Shamir Duo™

A highly personalised single vision lens

What it is

A single vision lens incorporating power corrections based on precise measurement of customers' individual prescriptions, and simulation of their perceived viewing fields.

Shamir Smart SV III As-worn™ offers single vision eyeglass wearers the sharpest and most comfortable eyesight. It does so thanks to breakthrough features, such as the highest degree of personalisation to individual prescriptions, and the most precise matching of viewing experience with specific choices of frame. Eye Point Technology™ embedded in Shamir Smart SV III As-worn™ ensures the lens provide the widest fields of clear vision, with As-Worn Quadro™ technology additionally guaranteeing that visual comfort and acuity precisely match the optimal viewing experience determined in optometrist measurements.

Who it's for

Eyeglass wearers of all ages requiring the most advanced prescription-compliant vision improvement in near or far zones.

Benefits

High personalisation, with lenses custom-designed to individual prescriptions.

Optimal visual experience with any frame of choice.

The broadest possible fields of clear vision.





A highly personalised single vision lens for the digital lifestyle

What it is

An advanced single vision lens available in three variants precisely personalised to the eyesight requirements of specific eyeglass wearer age ranges, and featuring an extra bit of power in its lower surface area for added visual comfort in the 40-to-70-centimeter digital display viewing zones.

Personalised for one of three distinct age ranges, Shamir Relax™ provides single vision eyeglass wearers – including those not specifically requiring corrective lenses – with a bit of extra power in its lower area. The lens makes close and intermediate viewing tasks easier, and specifically helps overcome the vision and constant focusing challenges typical to continuous use of digital displays. As its name implies, Shamir Relax™ provides relief and helps eyeglass wearers do exactly that – relax, and enjoy greatly minimised eye dryness and fatigue, tearing, headaches and blurry vision at the end of long days in front of computer and digital device screens.

Who it's for

Eyeglass wearers aged 18 to 45, requiring clear vision with age-specific personalisation, and dedicated support for frequent use of personal computers and handheld digital devices.

Relax™ +0.50	Relax™ +0.65	Relax™ +0.80
Ages 18-29	Ages 30-39	Ages 40-45





Benefits

High personalisation, with lenses customised to eyeglass wearers' age-driven visual requirements.

The broadest possible fields of clear vision.

Unprecedented support for comfortable digital handheld device and computer viewing.

Greatly reduced eye strain and fatigue.

A personalised single vision lens for sunglasses

What it is

A highly personalised single vision sunglass lens ensuring clear, undistorted vision across its entire surface, even when fitted to large, curved frames.

Shamir Attitude III SV™ offers single vision sunglass wearers sharp and distortion-free, prescription-personalised vision. It provides full clarity and an expanded peripheral viewing field across even the largest of curved frames, with As-Worn Quadro Technology™ additionally guaranteeing that visual comfort and acuity precisely match the desired viewing experience established in optometrist measurements.

Who it's for

Outdoor sunglass wearers of any age requiring clear vision and prescription-specific personalisation.





Benefits

High personalisation, with lenses custom-designed as per individual prescriptions.

Optimal visual experience with any frame of choice, including even the most unusual fashion and performance sunglass frame designs.

The broadest possible fields of clear vision.

Progressive lenses

Shamir Autograph Intelligence™

Shamir Autograph IIID™

Shamir Autograph InTouch UX™

Shamir Autograph Urban™

Shamir Spectrum™

Shamir Spectrum+™

Shamir Driver Intelligence™

Shamir Attitude III Sport™

Shamir Attitude III Fashion™

Single vision lenses

Shamir SV III As-worn™

Shamir Relax™

Shamir Attitude III SV™

Occupational lenses

Shamir Computer™ / Workspace™

Shamir Smart Office™

Vocational Digital

Bifocal lenses

Shamir Duo™

Lenses providing an optimal visual experience in desktop computing and workspace environments

What it is

Lenses designed to significantly improve visual clarity and comfort in the 35 centimeter to 1.5 or 3 meter range.

Shamir Computer™ and Workspace™ lenses feature power profiles uniquely optimised for near vision zones. Suitable for small, closed workspaces, Shamir Computer™ provides visual clarity and comfort in the 35 centimeter to 1.5 meter range typically required for convenient reading and computer usage.

Shamir Workspace™ offers similar functionality, while extending visual reach for larger offices open spaces, and delivering visual comfort at even greater distances ranging up to 3 meters. Both lenses accommodate the most natural and ergonomic viewing postures, helping to reduce the need to tilt one's head forward or back, or lower or raise objects to achieve convenient viewing

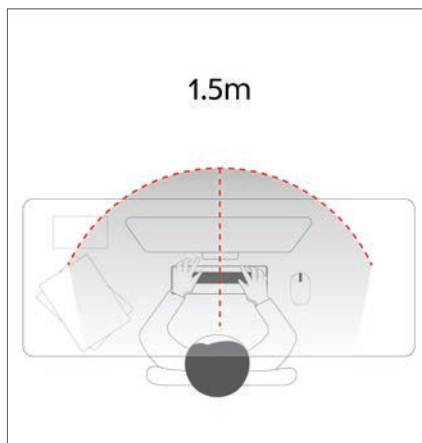

Enhanced 35cm-to-1.5m viewing field provided by Shamir Computer™ lens

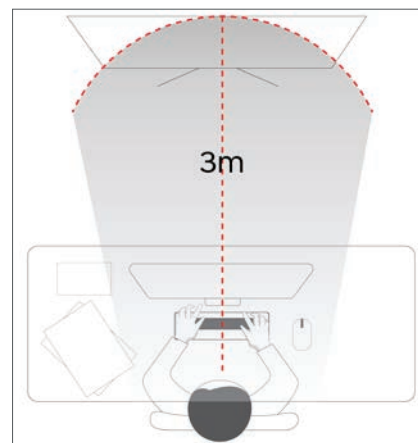

Enhanced 35cm-to-3m viewing field provided by Shamir Workspace™ lens



A woman with dark, curly hair and glasses is looking at a smartphone. She is wearing a dark, patterned shirt. The background is a light blue wall. A large red semi-circle is overlaid on the left side of the image, containing text.

Benefits

Unprecedented near zone visual comfort when using computers and performing desktop activities.

Wide, comfortable viewing field for reading.

Natural and ergonomic viewing postures.

Reduced eye strain and fatigue.

Who it's for

Reading, bifocal or progressive eyeglass wearers aged 40 and up, requiring vision improvement in near vision zones when spending the majority of their workday at their desk and in front of computers.

A lens offering an optimal visual experience in office environments

What it is

A dynamic workspace-dedicated lens designed to significantly improve visual clarity and comfort in the 35 centimeter to 4 meter range.

Shamir Smart Office™ features a dynamic power profile uniquely optimized for near to intermediate vision zones. It specifically provides visual clarity and comfort in the 35 centimeter to 4 meter range required for convenient reading, computer usage and a range of additional activities in and around office environments. Shamir Smart Office™ accommodates the most natural and ergonomic viewing postures, reducing the need to tilt one's head forward or back, or lower or raise objects to achieve convenient viewing.

Who it's for

Eyeglass wearers aged 40 and up, requiring near and intermediate zone vision improvement, and the greatest visual comfort when reading, using computers or performing other office activities.



Single vision viewing posture

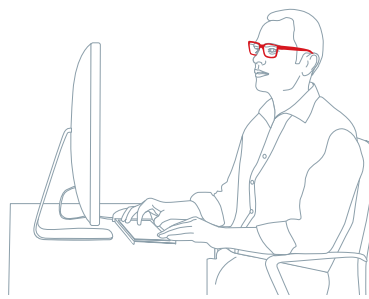

Progressive/bifocal viewing posture

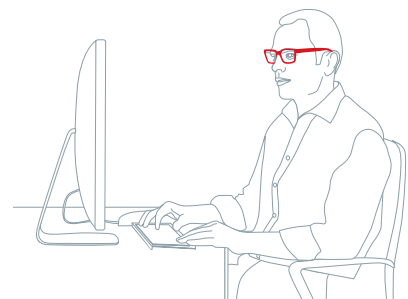

Shamir Smart Office™ natural head posture

Featured technologies





Benefits

Unprecedented, dynamic support for near and intermediate zone office activities.

Wide, comfortable viewing field for reading.

Natural and ergonomic viewing postures.

Reduced eye strain and fatigue.

An improved occupational lens, now in digital-freeform

What it is

Shamir Vocational Digital answers the needs of a wide range of professionals and is specifically designed for the work environment. As an ideal alternative to reading glasses, Shamir Vocational Digital is the solution for those looking for perfect focus for near and mid-distance work.

Vocational Digital provides wearers requiring near and mid-distance zone vision improvement the greatest visual comfort when reading, using digital devices or performing other office activities.

Lenses providing an enhanced visual experience for desktop and dynamic working environments

Shamir Vocational Digital is a dynamic workspace-dedicated lens designed specifically to significantly improve visual clarity and comfort in digital workspaces.

- Clearer vision.
- Available in clear, Transitions (index 1.5, 1.53 and 1.6), or Shamir Blue Zero™ (index 1.5 and 1.6).
- Available in 1.5, and 1.6 index.
- A more affordable option to traditional occupational lenses.

Shamir Vocational Digital answers the needs of a wide range of professionals and is specifically designed for the work environment. As an ideal alternative to reading glasses, Shamir Vocational Digital is the solution for those looking for perfect focus for near and mid-distance work.

Who it's for

- People looking for a better solution to traditional reading glasses.
- People with a need to focus on near and mid-distance work.



Progressive lenses

Shamir Autograph Intelligence™

Shamir Autograph IIID™

Shamir Autograph InTouch UX™

Shamir Autograph Urban™

Shamir Spectrum™

Shamir Spectrum+™

Shamir Driver Intelligence™

Shamir Attitude III Sport™

Shamir Attitude III Fashion™

Single vision lenses

Shamir SV III As-worn™

Shamir Relax™

Shamir Attitude III SV™

Occupational lenses

Shamir Computer™ / Workspace™

Shamir Smart Office™

Vocational Digital

Bifocal lenses

Shamir Duo™

An advanced bifocal lens combining clear vision with maximum aesthetics

What it is

A bifocal freeform lens that aesthetically conceals the line separating its upper and lower vision segments, while ensuring the smoothest transition between near and far vision zones.

Shamir Duo™ is designed to address the limitations of traditional bifocal lenses – namely their negative aesthetic association with elderly people, and the jarring temporary loss of sight experienced when shifting one's eyes between their near and far vision zones.

Duo™ overcomes these challenges by effectively eliminating the highly visible upper and lower lens segment separation line, while continuing to ensure a smooth transition between near and far vision zones. The lens ultimately allows customers to enjoy many of the benefits of progressive lenses – including compatibility with a range of materials, tints and coatings – in a bifocal format ideally tailored to both visual needs and aesthetic preferences.





Benefits

Instant focus on and smooth transition between near and far vision zones.

Flawless, youthful appearance.

Full compatibility with tinted, photochromic and polarised sunglass applications, as well as with a range of advanced coatings.

Availability in a broad selection of materials, including high index for thin, aesthetic lenses.

Who it's for

Aesthetic-conscious eyeglass wearers aged 40 and up, requiring near and far vision improvement, yet reluctant or otherwise unable to adapt to progressive lenses.



COATINGS.....

- SHAMIR GLACIER™ PLUS™ UV
- SHAMIR GLACIER EXPRESSION™
- SHAMIR GLACIER™ SUN™ UV
- SHAMIR POWER MIRRORS™
- SHAMIR GLACIER™ BLUE-SHIELD UV™

SPECIAL MATERIALS.....

- SHAMIR BLUE ZERO™
- SHAMIR TRIBRID™ MATERIAL
- SHAMIR TRIVEX® BLUE ZERO™
- SHAMIR LENS MATERIAL OPTIONS

Coatings

Shamir's specialised coatings are designed to enhance the appearance, performance, and durability of the Shamir spectacle lens.

Shamir Glacier™ Plus™ UV

Shamir Glacier Expression™

Shamir Glacier™ Sun™ UV

Shamir Power Mirrors™

Shamir Glacier™ Blue-Shield™ UV



Coatings. The invisible protectors.



Lens coatings can enhance eyeglass aesthetic appearance, durability, and performance, and Shamir's high quality coatings are among the world's very best.

Protection for your glasses

Coatings are so inconspicuous, yet so effective at making glasses better, whether as a hardened layer safeguarding lenses against scratching or a premium anti-reflective add-on reducing annoying glare and reflections. They improve visual comfort, make eyeglasses easy to clean, and even ensure that they last longer.

Protection for your eyes

The broad wavebands of sunlight and artificial lighting carry some often overlooked threats, coatings can be truly indispensable in protecting the eyes against these hidden potential hazards. They can help block ultraviolet light to avoid the risk of damage to the cornea and retina over time. Coatings can also filter out the eye fatigue and headache-inducing blue light eyeglass wearers may be exposed to when working with computers and other backlit digital displays, or when out and about in the sun.

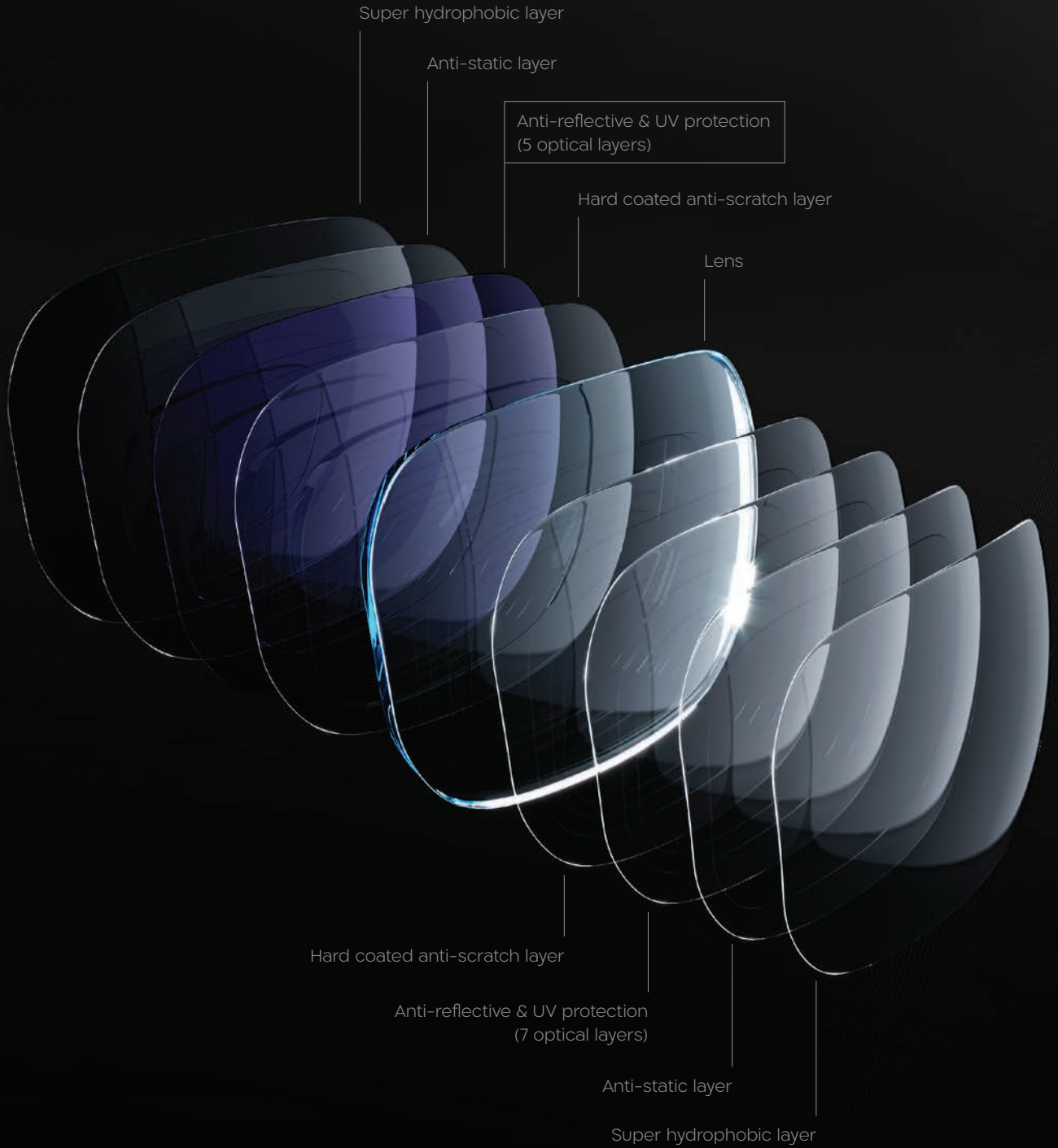

Powerful UV protection for the eyes

The Shamir Glacier™ Plus UV coating provides comprehensive protection for the eyes against ultraviolet rays. In high index lenses (1.53 and up), it will even ward off UV rays in both incoming light and light reflected off rear lens surfaces.

This advanced coating is built to last. It won't wear off or scratch, makes lenses easy to clean, and keeps them constantly clear of distracting reflections.

Its anti-reflective properties significantly increase light transmission, contributing to a greatly improved visual experience.

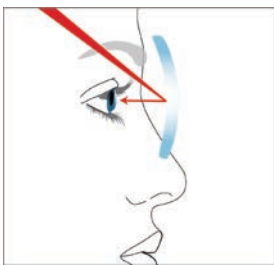

Standard AR coating:
high reflection



Shamir Glacier Plus UV:
low reflection

Recommended for:

Eyeglass and sunglass wearers of any age.

Benefits

Comprehensive ultraviolet protection (blocks UV in both incoming light and light reflected off rear lens surfaces in high indexes of 1.53 and up).

Minimised glare for maximum visual clarity and comfort.

Enhanced durability and scratch-resistance.

Anti-static, hydrophobic and oleophobic, keeping lenses clean of dust and fingerprints.

The new anti-reflective coating that lets you truly express yourself

The product of extensive research and development, Shamir Glacier Expression raises the bar by utilizing a greater number of layers than those implemented in traditional coatings, while retaining a similar thickness and durability level. This enables it to specifically regulate those light wavelengths that the human eye is most sensitive to, and achieve enhanced control over reflectance. **The result** – letting your patients look, see and feel better.

When eyeglass lenses reflect screen glare and other light sources, this not only reduces visual clarity but also obscures others' view of our eyes.

Shamir Glacier Expression – our new, innovative lens coating is designed to effectively overcome this, reducing reflections to enable clear, detailed vision.

Recommended for:

Eyeglass wearers of all ages, any time, every day.

THE CLEAR WINNER
96% overall satisfaction

* Based on research with over a hundred eye care professionals around the world



Glacier Expression
Powerful anti-reflective properties

Standard Premium coating

LOOK BETTER
Improved aesthetics
up to 70% less reflections

SEE BETTER
Visual clarity & detail **+25% improvement** in contrast sensitivity

FEEL BETTER
99% of ECPs reported on increased comfort & visual acuity

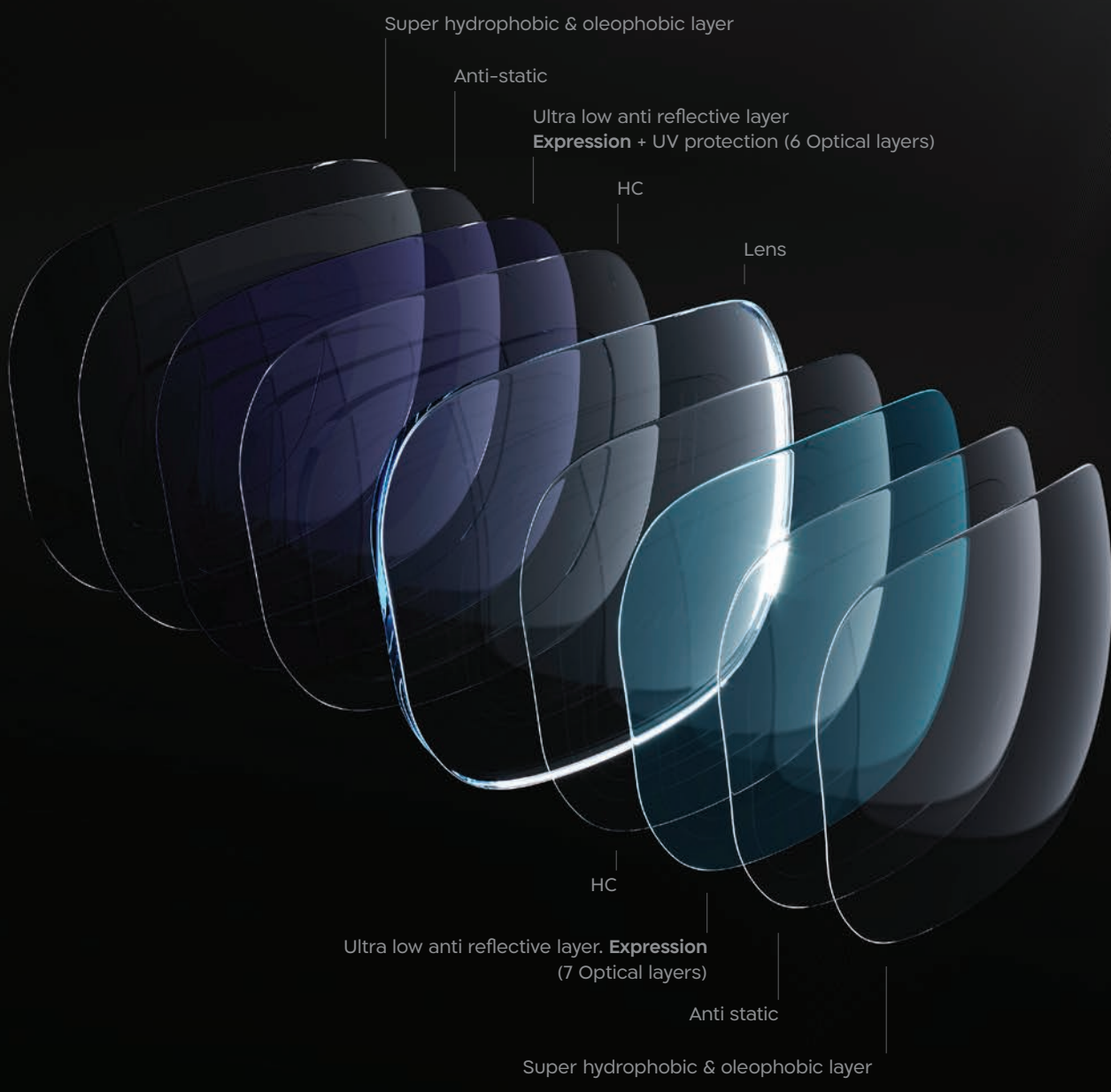

Super hydrophobic & oleophobic layer

Anti-static

Ultra low anti reflective layer
Expression + UV protection (6 Optical layers)

HC

Lens

HC

Ultra low anti reflective layer. **Expression**
(7 Optical layers)

Anti static

Super hydrophobic & oleophobic layer

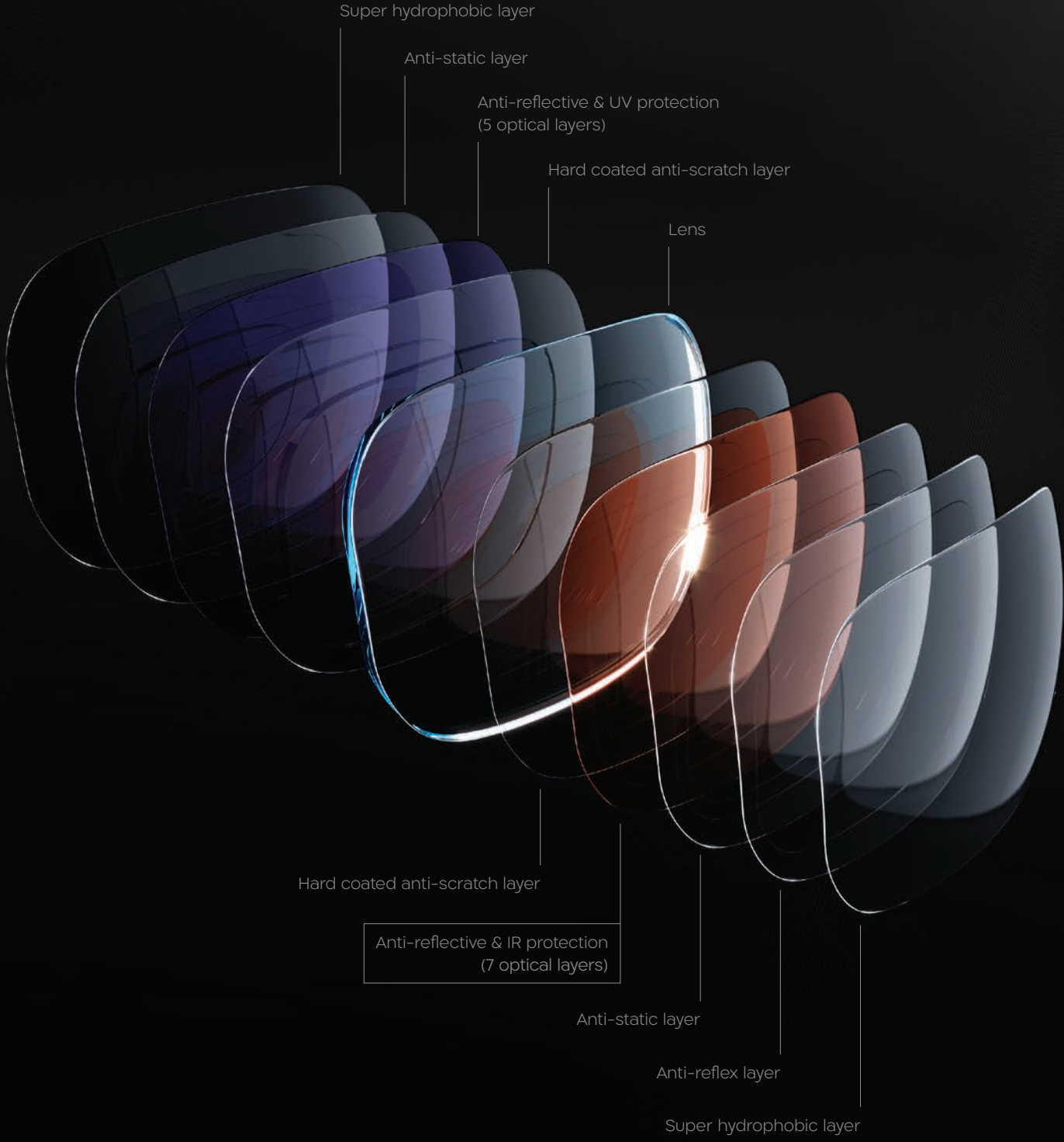

A lens coating designed for sunwear.

Glacier™ Sun™ UV accommodates a wide range of fashion preferences, lifestyles, and activities, while providing maximum sun protection and visual comfort.

This advanced coating is fully clear, protecting from the lens from colour fade without changing the lens tint. In addition to UV protection, Shamir Glacier™ Sun™ UV prevents reflected sunlight from bouncing from the rear surface of the lens by absorbing harmful UV and UVA rays into the lens, providing extra protection from damaging reflected light.



Standard AR coating:
high reflection



Shamir Glacier™ sun™ UV:
low reflection

Recommended for:

Eyeglass and sunglass wearers of any age.

Benefits

The only anti-reflective coating designed for prescription sunglasses. Ideal for all tinted & polarised lenses.

Eliminates internal reflections as the anti-reflective coating lets light pass through.

Offers full UV protection with front and back UV coating.

Anti-static, oleo & Hydro-phobic for easy cleaning, durability, scratch resistance.



Shamir
Power Mirrors™

Discover the new mirrored treatment.

Shamir Power Mirrors™ is a state-of-the-art treatment that comes in a range of high-density, highly reflective colours.

Not only are Power Mirrors™ a popular fashion add-on, they're highly functional and ideal for sports and fashion sunglasses to create a fun and edgy look.

The outer layer of the Power Mirrors™ coating features advanced hydrophobic and oleophobic properties, so they're easy to clean and resistant to water stains and marking.

Important: The intensity of the Power Mirror finish will be reliant on the colour depth of the lens. Darker colour lenses will result in a more intense finish.

Colours Options:

Silver | Gold | Rose Gold | Green | Blue | Red | Orange



Benefits

Unique aesthetic appeal via high-density, highly reflective colours

Easy to clean, with high resistance to water, stains, grease and fingerprints



Effective blue light protection for the eyes

Life in the modern world has us under constant exposure to artificial light from a broad range of sources, including computer monitors, tablets, smartphone screens, televisions, and more. The key cause for concern stems from the HEV (High Energy Visible) light they emit, also referred to as blue light, which over time, can damage our retinas.

Shamir Glacier™ Blue-shield™ UV is an innovative lens coating designed to address exactly this threat.

Deflecting up to five times as much blue light as traditional lens coatings, it significantly improves light transmission and contrast, reduces eye strain and fatigue, and ultimately helps maintain visual health.

Recommended for:

Eyeglass wearers of any age, who spend significant amounts of time indoors, and are continuously exposed to blue-violet screen light.

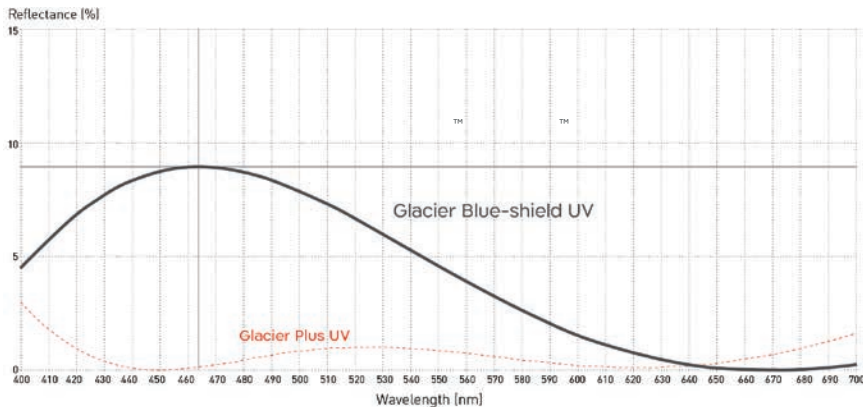

Reflectance comparison - Shamir Glacier™ Blue-shield™ UV vs. Shamir Glacier™ Plus™ UV

Special Materials

Shamir's broad range of lens materials cover a wide variety of needs, from high-index prescriptions to improved comfort and aesthetics.

Shamir Blue Zero™

Shamir Tribrid™ Material

Shamir Trivex® Blue Zero™

Shamir Lens Material Options



Benefits

Powerful blue light protection greatly reduces retinal HEV light exposure.

Improved light transmission for enhanced visual clarity.

Reduced eye strain and fatigue.

Rear lens anti-reflective properties for comprehensive UV protection.



Shamir
Blue Zero™

Lens-embedded blue light protection

Prolonged exposure to the UV and blue light emitted by the sun and artificial sources is a well-known threat to ocular health. It is also the potential cause of a range of other general health disorders, including disruption of natural sleep cycles.

To address this threat, Shamir has developed Blue Zero™, a unique polymer formula-based lens material featuring built-in blue light protection, which effectively absorbs UV and HEV (High Energy Visible) light. In addition to blocking just the right amount of blue light to keep eyes healthy. Shamir Blue Zero™ lenses maintain contrast sensitivity, ensuring high visual clarity and colour perception.

Recommended for:

Prescription or plano lens wearers of any age.

Benefits

Embedded ultraviolet and blue light protection greatly reduces retinal HEV light exposure and maintains visual health.

Improved light transmission for enhanced visual clarity and comfort.

High contrast sensitivity and colour perception.

Reduced eye strain and fatigue.

Integrated UV protection.



Shamir Tribrid™
Material

Clear, light, thin, strong

For patients with stronger prescriptions, the hybrid Shamir Tribrid™ material combines the best attributes of Hi-Index lenses with the comfort, strength, and durability of Trivex® material.

Excellent for rimless, nylon, and inline fits and patients who want lightweight eyewear that doesn't sacrifice on strength.

Benefits

Available in most Shamir FreeForm Lenses.

- Spectrum™
- Intouch™
- Autograph II™
- FreeFrame™
- First Pal™
- Autograph Attitude™
- Smart Attitude™
- Smart SV™
- Relax™
- Ski™
- Run™
- Standard Grind
- Smart Office™
- Smart Computer™
- Smart Workspace™

Redefining Hi-Index

A revolutionary lens technology that combines the best lens properties to provide your patients with enhanced all-around performance for their prescription requirements.

Optical Clarity

With every prescription, clear vision is always important. Tribrid™ lenses feature precision optics to optimise prescriptions and meet your patients' needs for clear vision at all time.

Thin & Light

The perfect balance of performance and comfort with the aesthetics and beauty of a thin lens. The lightest high index material available provides all-day comfort.

Strong & Durable

Tribrid™ lenses provide a stronger lens for your patients and that means enhanced safety, durability and confidence in every lens.

Right for Everyone

Tribrid™ lenses offer more benefits and overall performance that is right for every patient. Perfect for children, active adults, seniors and those with an eye towards fashion...and they're compatible with all frame styles and designs.



Shamir
Trivex® Blue-Zero™

Lightweight and impact resistant for extraordinary performance.

Shamir's optical expertise has now combined Blue Zero™ with scientifically advanced Trivex® material. The result is Shamir Trivex® Blue Zero™, the latest line of lenses offering extraordinary performance characteristics.

By combining Trivex® with Shamir's industry leading Blue Zero™ material offers the best eye protection available. It's ideal for engaging in sports, working in hazardous environments, or for general everyday protection against life's surprises.

Recommended for:

Children, sports, work in hazardous environments.

Benefits

Embedded ultraviolet and blue light protection greatly reduces retinal HEV light exposure and maintains visual health.

Strong and lightweight protection.

Improved light transmission for enhanced visual clarity and comfort.

Reduced eye strain and fatigue.

High performance for indoor and outdoor use.



Materials to match every lifestyle need

Shamir lens material options

At Shamir, we believe that materials matter. That's why we offer a broad range of lens materials for a wide variety of needs. A strong prescription can result in thick plastic lenses. We therefore

manufacture our lenses from high-index plastics or polycarbonates, which reduce lens thickness, and ultimately improve comfort and overall aesthetics.

Lens thickness comparison Minus lenses

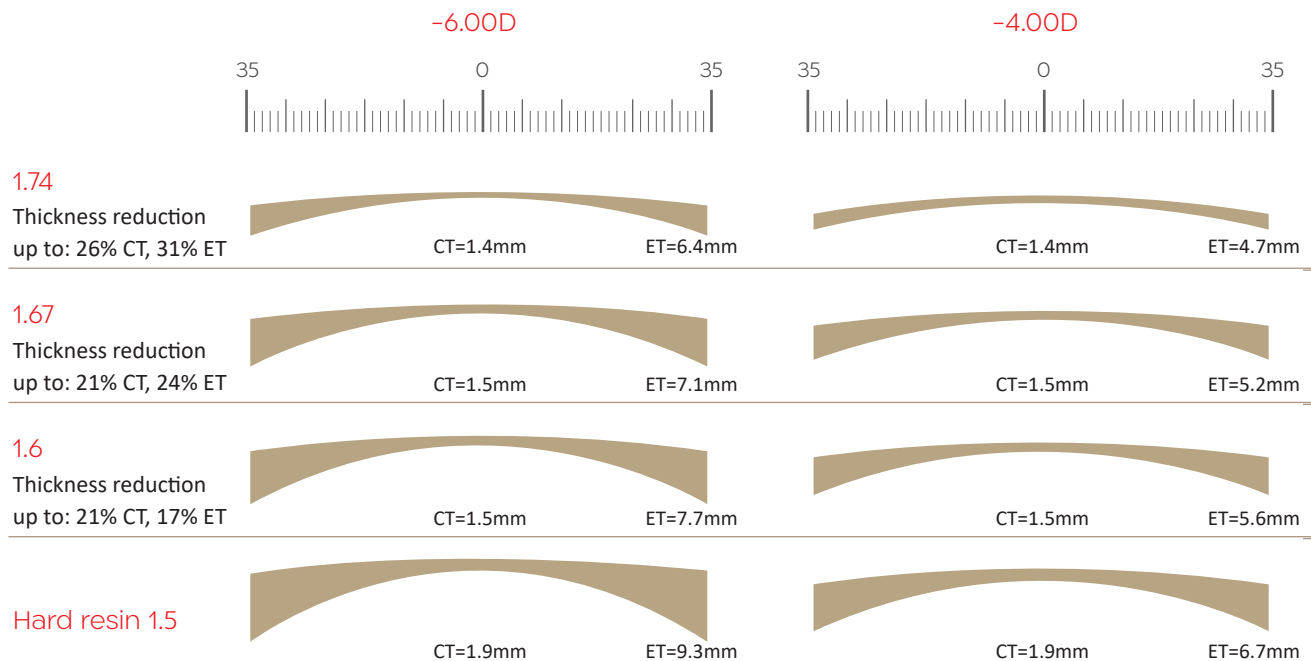

CT= Centre thickness
 ET= Edge thickness
 Thickness reduction vs index 1.5



Lens thickness comparison

Plus lenses

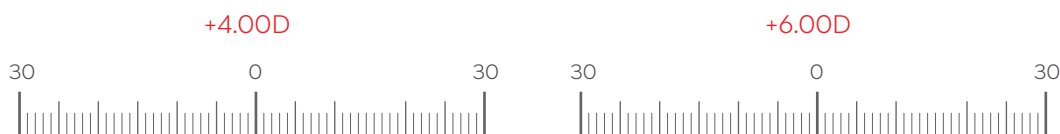

1.74

Thickness reduction
up to: 31% CT, 20% ET



1.67

Thickness reduction
up to: 25% CT, 20% ET



1.6

Thickness reduction
up to: 18% CT, 20% ET



Hard resin 1.5

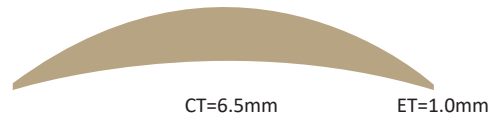

CT= Centre thickness

ET= Edge thickness

Thickness reduction vs index 1.5

* Pictures are for illustration purposes only.

PICK THE PERFECT LENS DESIGN

- SHAMIR ATTITUDE III FASHION™
- SHAMIR ATTITUDE III SPORT™
- SHAMIR ATTITUDE III SV™

CHOOSE YOUR PERFECT LOOK

- SHAMIR SUN COLOURS™
- SHAMIR POWER MIRRORS™

ENJOY PERFECT PROTECTION

- SHAMIR POLARIZED LENSES
- SHAMIR GLACIER SUN UV™
- SHAMIR GLACIER ANTI-FOG™
- NUPOLAR® GRADIENT™
- NUPOLAR® INFINITE™
- NUPOLAR® MIRRORS™
- TRANSITIONS® LIGHT INTELLIGENT LENSES™
- TRANSITIONS® SIGNATURE® GEN 8™
- TRANSITIONS® STYLE COLORS® LENSES
- TRANSITIONS® XTRACTIVE® LENSES
- TRANSITIONS® DRIVEWEAR® SUN LENSES



PICK THE PERFECT
LENS
DESIGN



Shamir
Attitude III Fashion™

A progressive sun lens for any fashion frame

Shamir Attitude III Fashion™ is precisely tailored to the individual prescriptions and dynamic vision zones of customers engaged in a modern lifestyle. It ensures a clear, undistorted visual experience outdoors in sunglass frames of any size and curvature.



Benefits

Optimal visual experience, even with large and curved fashion sunglass frame designs.

Instant focus and clear vision in intermediate, far, and peripheral vision zones, with dedicated support for near zone use of handheld digital devices.

Seamless transition among vision zones.

Featured technologies





Shamir
Attitude III Sport™

A progressive sun lens for sports and active lifestyles

Shamir Attitude III Sport™ is prescription-tailored to deliver clear, undistorted vision, specifically in the zones characteristically focused on by people engaged in sports and in active lifestyles.



Benefits

Optimal visual experience with curved sunglass frames.

Instant focus and clear vision in intermediate, far, and peripheral vision zones, with dedicated support for near zone use of fitness bands and smartwatches.

Seamless transition among vision zones.

Featured technologies





Benefits

High personalisation, with lenses custom-designed as per individual prescriptions.

Optimal visual experience with any frame of choice, including even the most unusual fashion and performance sunglass frame designs.

Exceptionally broad fields of clear vision.



Shamir
Attitude III SV™

A personalised single vision lens for sunglasses

Shamir Attitude III SV™ is a highly personalised single vision sun lens that helps ensure clear, undistorted vision across its entire surface, even when fitted to large, curved frames.

Featured technologies





CHOOSE YOUR
PERFECT
LOOK



Shamir
Colours



New shades of performance

Shamir offer tinted lens solutions for a range of aesthetic and performance requirements.

More than just a fashion statement, lens tints are widely recognised today for their visual performance enhancement capabilities during activities in indoor and outdoor environments. Shamir Colours brings you beautiful lenses that improve visual performance and comfort.

Shamir Color



Benefits

Maximum visual comfort through reduced brightness and glare.

Enhanced outdoor visual acuity.

Powerful UV protection for the eyes.



Shamir
Power Mirrors™

Innovative reflections of beauty

Shamir Power Mirrors™ is a state-of-the-art, highly reflective lens treatment available in a range of high-density colours, including silver, gold, green, blue, red, orange, and rose gold. With outer layers featuring advanced hydrophobic and oleophobic properties, Power Mirrors™ treated lenses repel water and grease, making them resistant to fingerprints and water marking, easy to clean, and the perfect match for sport and fashion sunglasses.

Benefits

Unique aesthetic appeal via high-density, highly reflective colours.

Easy to clean, with high resistance to water, stains, grease and fingerprints.







ENJOY

PERFECT
PROTECTION



Shamir Polarised Lenses

Effective glare neutralisation

Coated with a special film that effectively neutralises sunlight glare, Shamir's polarised lenses deliver clear vision, while improving contrast, preventing distortion of natural colours and even protecting against potentially harmful UV light. They're the ideal choice for all eyeglass wearers, delivering safety and performance benefits for drivers, as well as sports and outdoor activity enthusiasts.



Benefits

Improved visual comfort and acuity via reduced glare.

Undistorted view of natural colours.

Increased contrast perception.

Reduced eye strain and fatigue.

Protection of the eyes against UV rays.

Perfectly clear vision in the sun

An advanced achromatic coating, Shamir Glacier™ Sun™ UV ensures high sunglass protection and visual comfort. Its UV and AR (anti-reflective) properties help deliver perfectly clear, bloom-free vision, and keep reflected sunlight from bouncing off rear lens surfaces into the eyes. Shamir Glacier™ Sun™ UV does not interfere with sun lenses chosen hue, and helps prevent their colour from fading.

Its antistatic, hydrophobic and oleophobic properties make it easy to keep lenses clean and ensures extraordinary scratch resistance and durability.



Shamir achromatic
AR coating

Standard
AR coating

Benefits

Lens colour maintenance and fade-proofing.

Enhanced UV protection.

Minimised glare.

High durability and scratch resistance.

Easy to clean, with high resistance to water, stains, grease and fingerprints.



Shamir
Glacier™ Anti-fog™

Fog-free lenses for athletes and active lifestyle enthusiasts

Shamir's Glacier™ Anti-fog™ is an innovative, ultra-thin lens coating that prevents rear lens surfaces from fogging. It effectively helps eyeglass wearers maintain performance-critical clear vision, especially during sports or other fast-paced activities. This unique technology completes Shamir's comprehensive vision solution – for enhanced sports performance.

Benefits

Fog-free rear lens surfaces for continuous clear vision.

Ready-to-use.

No activation needed.

EN-166 standard compliant.

Can be applied to any frame.





YOU'VE

NEVER

SEEN

BETTER

NUPOLAR[®]

polarized lenses



The world's #1 RX polarised lens.

Not all polarised lenses are created equal in quality and performance. NuPolar® has perfected its technology in design and development for decades to become a true and accepted global standard in polarised lenses.

As one of the world's leading brands of polarised prescription lenses, NuPolar® sets the benchmark for stringent performance characteristics of optics, polarised film technology, colour consistency, material sciences, and more.

Blocks Blinding Everyday Light

When light hits reflective smooth surfaces such as roads, water, car bonnets, snow, buildings, wet surfaces or even the bright chrome of the car in front, the light becomes polarised. The polarised light creates blinding glare that seriously inhibits vision and compromises safety. NuPolar® polarised lenses block out dangerous blinding glare that reflect from these surfaces.

True Colours, Comfort & Improved Contrast

In addition to blocking blinding glare, NuPolar® polarised lenses also help wearers see better by improving contrast and visual comfort.

NuPolar® Outperforms All Other Polarised Lenses

Tests prove no other polarised lens on the market come close to NuPolar® lenses in overall performance. When performance factors such as optics, polarising efficiency, colour consistency, heat stability and other critical factors are taken into consideration, NuPolar® comes #1.

Benefits

Always designed to ensure a thin lens for better cosmetics for wearers.

Excellent film adhesion, eliminating delamination.

Designed to be FreeForm friendly.

Long lasting durability and quality wearer satisfaction.





Look good and see more

Gradient lenses are coveted by the fashion-conscious. To create the on-trend look, the lenses are darker at the top and gradually fade to light at the bottom.

Prescription lens wearers need never compromise on fashion and sophistication; now, with the new gradient, they can have the look they want with the prescription and polarisation they need.



Benefits

On-trend gradient tint with world leading technology.

Encapsulated gradient preventing fading over time.

100% UV blockage.

Consistent matching so the right and left lenses always match perfectly.



NUPOLAR[®]
infinite



Adapt to your adventure

NuPolar® Infinite™ is a polarised photochromatic lens that automatically changes from light grey to dark grey to suit a wearers' current light conditions.

Always polarised, the photochromatic technology quickly reacts to UV light to darken or lighten as each light condition warrants, enabling wearers to seamlessly enjoy comfortable and optimal vision in any outdoor daytime condition.

NuPolar® Infinite™ is available in static tints in solid, gradient, and mirror styles.

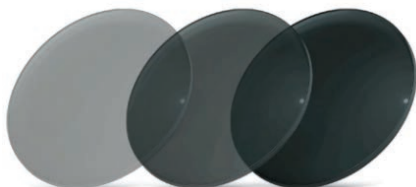

Lightest state - Light Grey

60% Tint

Darkest state - Dark Grey

91% Tint

UV Blockage

100%

Benefits

Darkens or lightens to suit conditions in seconds.

Optimal daytime vision from dawn until sunset.

More vibrant, brilliant, and comfortable vision.

Maximum eye protection with 100% UV blockage and glare protection.

Transitions®

Shamir offers a broad range of Transitions® light responsive lenses to cover a range of needs.

Transitions® Light Intelligent Lenses™

Transitions® Signature® GEN 8™

Transitions® XTRActive® Lenses

Transitions® Drivewear® Sun Lenses



Transitions® Light Intelligent Lenses™ automatically adapt to changing light conditions

Responding to the light around you, they intelligently change from clear to dark when you go outdoors and back to clear when you return inside.

By optimising the amount of light your eyes receive, *Transitions® lenses* also help reduce glare, eye fatigue and strain, for more effortless sight.

Transitions® offer a choice of products tailored to your eyecare needs and are available in a wide range of stylish lens colours so you can express your personal style.



Light Intelligent
Automatically adapting to changing light conditions.

Everyday Eyecare
Blocks 100% UV rays. Plus helps protect against harmful blue light indoors & outdoors.

Hassle Free
Make everyday life simpler.

Free Style
Whatever the frames you love, pick your favourite colour. Choose your style.



Take control of
your light and
enjoy hassle-
free protection
anytime, anywhere
on any device -
indoors and out!





NEW Technology NEW Frontier of performance

The perfect lens for everyday life. Constantly adapts to all light situations for better vision, comfort and protection.



Grey



Brown



Graphite green



Sapphire



Amethyst

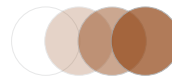

Amber



Emerald

Benefits

Fully clear indoors.

Darkens outdoors in seconds.

Returns to clear faster than ever.

Protects your eyes indoors & outdoors.



Benefits

Extra dark outdoors,
even in hot
temperatures.

Ultimate protection
in the brightest sun /
Activates in the car.

Clear indoors, with
a hint of protective
tint.



 **XTRACTIVE**[®]
NEW GENERATION

Best xtra darkness, best xtra
light protection**

Transitions[®] XTRACTive[®] new generation lenses are especially designed to deliver the best extra darkness and the best extra light protection* that very light sensitive eyeglass wearers and people who are exposed to intense bright light expect. They utilize the most advanced, cutting-edge technology to achieve an evolutionary leap in clear-to-extra dark performance.



Grey



Brown



Graphite green



Benefits

Extra dark outdoors, even in hot temperatures.

Ultimate protection in the brightest sun / Activates in the car.

Clear indoors, with a hint of protective tint.

 **Transitions**
XTRACTIVE[®]
POLARIZED[™]

The only and best ever polarised photochromic lenses*

Transitions XTRActive Polarized lenses are designed for wearers who want extra protection in high-glare situations. Indoors they are clear with a hint of tint and outside they achieve a polarisation efficiency of up to 90%1, which is similar to polarised sunglasses.



Grey



Frames by Ici Berlin - Lenses Transitions® Brown



Better vision behind the wheel

The only polarised sun lenses that are designed to activate both behind the windscreen and outdoors responding to UV and visible light.



Benefits

Continuously adapting to reduce glare and optimise colour contrast.

Better manage changing daylight and weather conditions for a safer drive.

Block 100% UV rays.

SHAMIR AUTOGRAPH INTELLIGENCE™

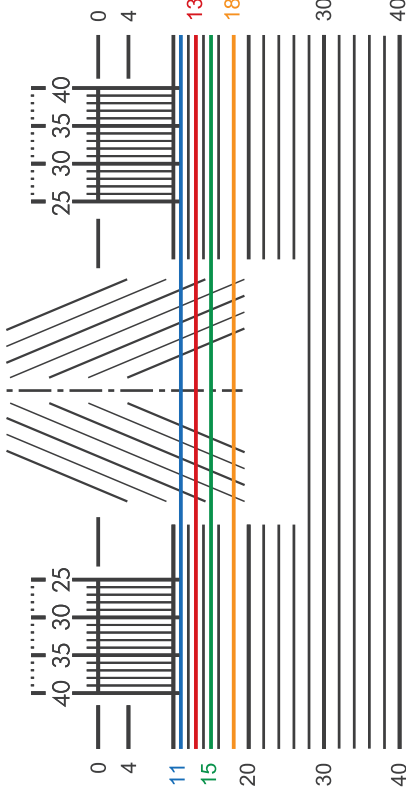
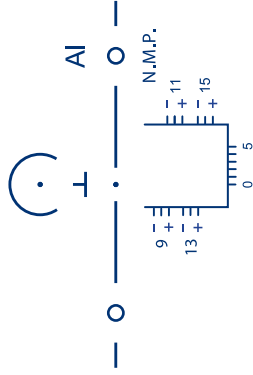

Minimum Fitting Heights: 13mm, 15mm, 18mm

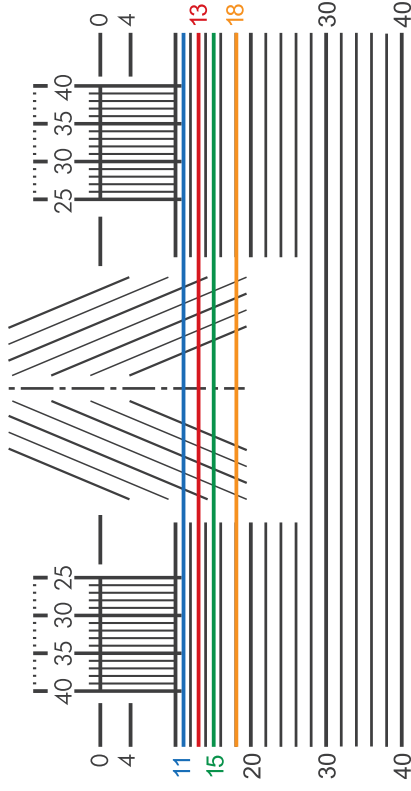
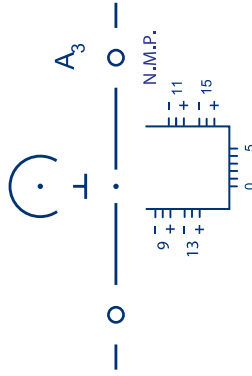

Minimum Fitting Heights: 13mm, 15mm, 18mm

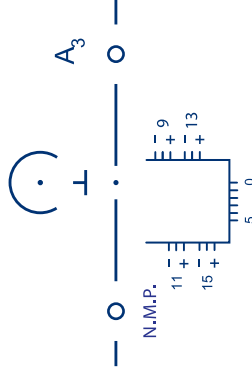
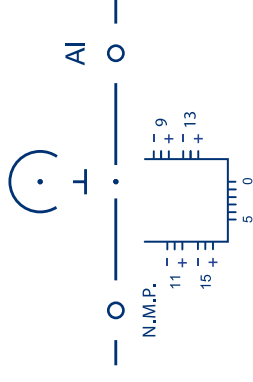

SHAMIR AUTOGRAPH INTOUCH UX™

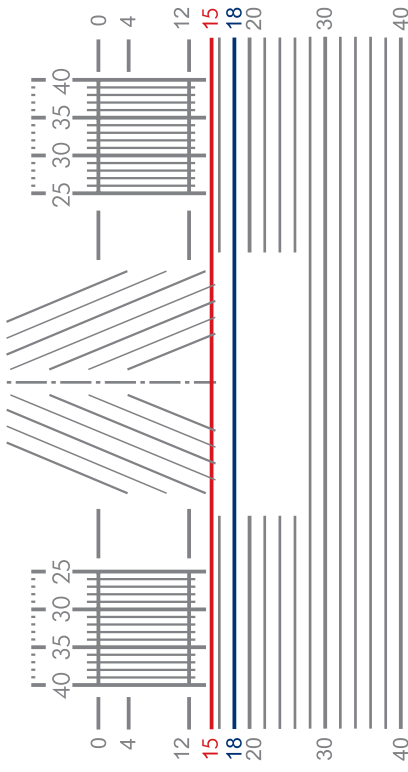
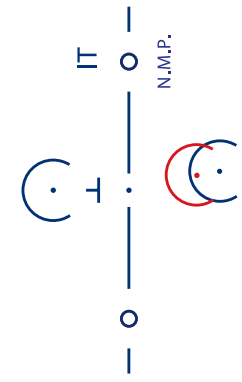

Minimum Fitting Heights: 15mm, 18mm

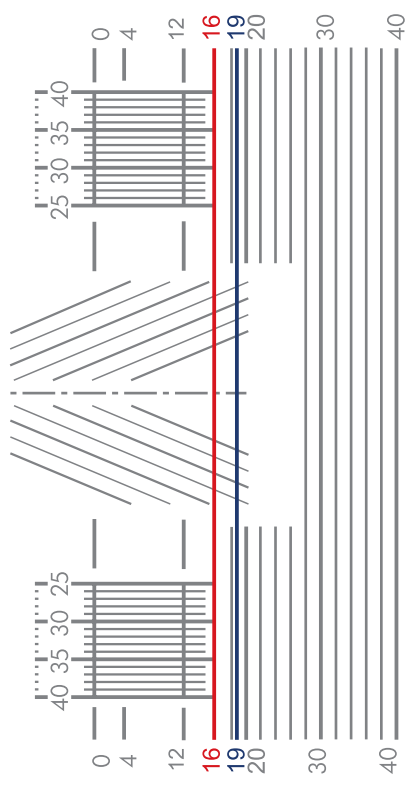
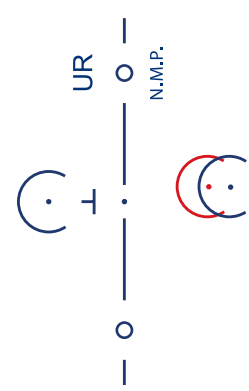

Minimum Fitting Heights: 16mm, 19mm

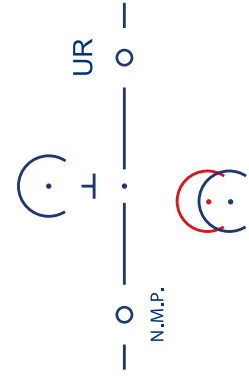
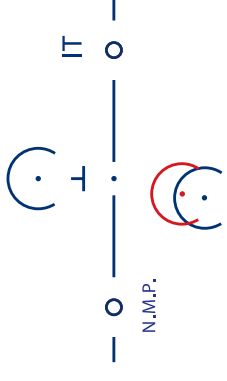

SHAMIR SPECTRUM+™

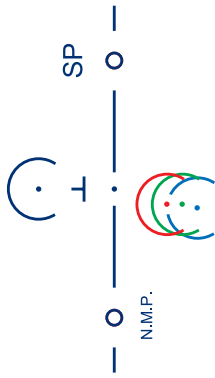
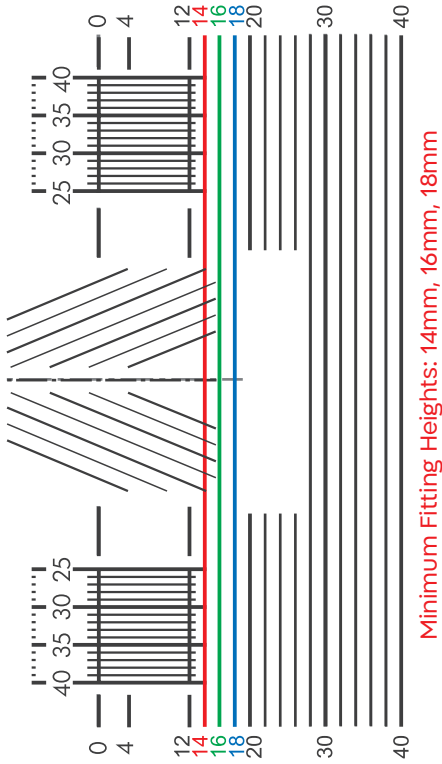

SHAMIR ATTITUDE™ III SPORT

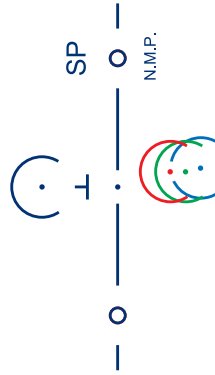
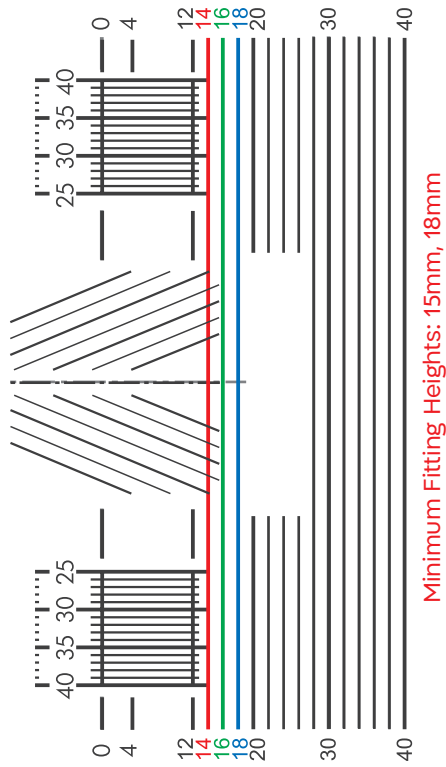

SHAMIR ATTITUDE™ III FASHION

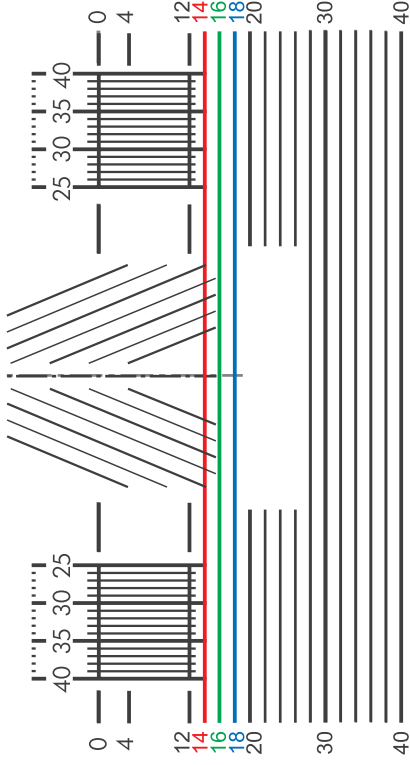
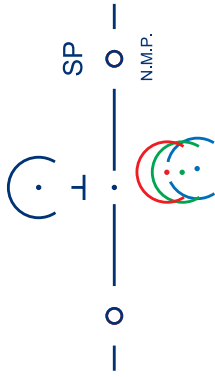

Minimum Fitting Heights: 15mm, 18mm

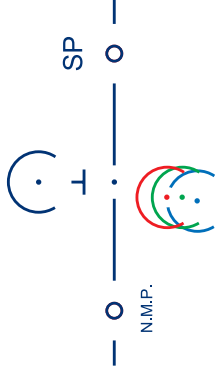

SHAMIR SMART OFFICE™

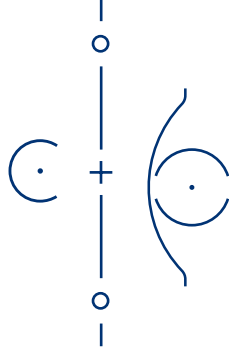
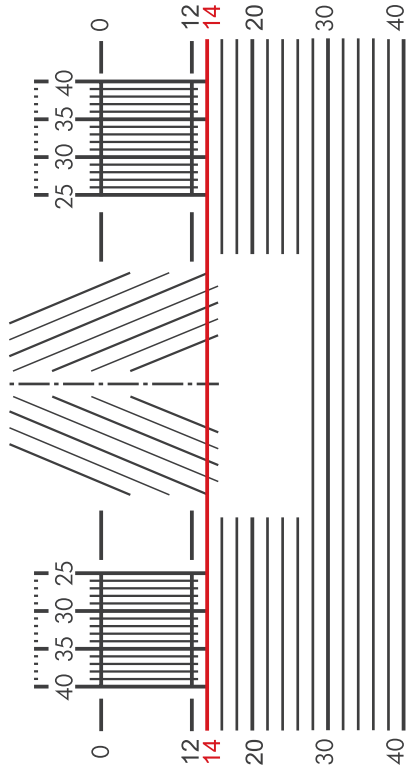
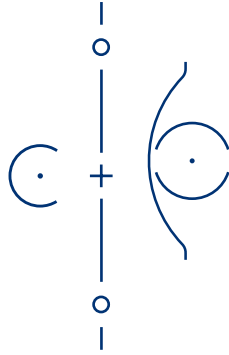

SHAMIR COMPUTER™

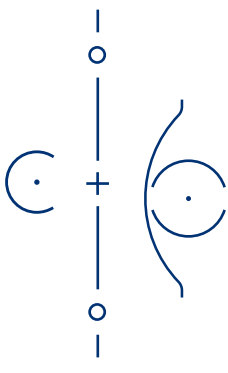
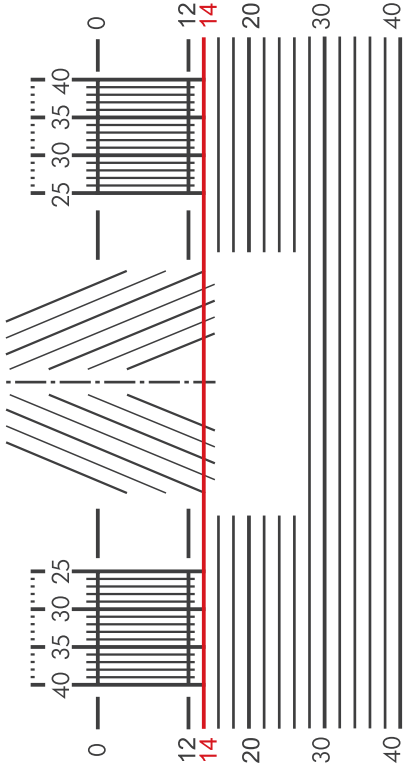
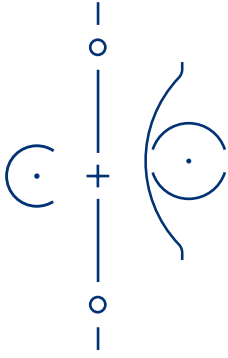

SHAMIR WORKSPACE™

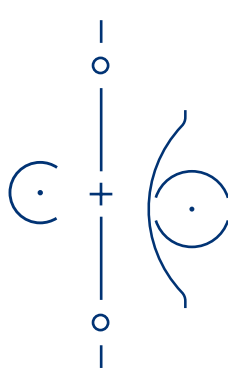
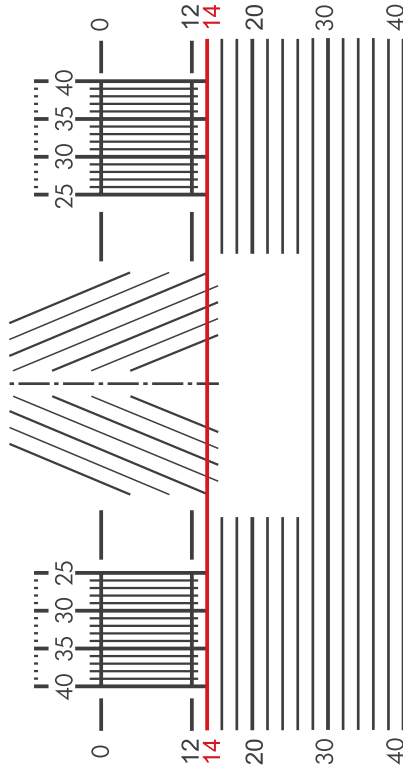
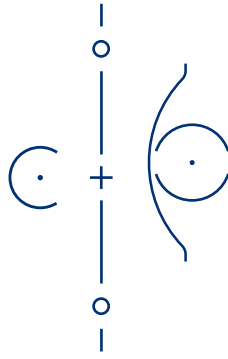

SHAMIR ATTITUDE™ III SV

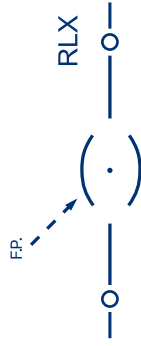
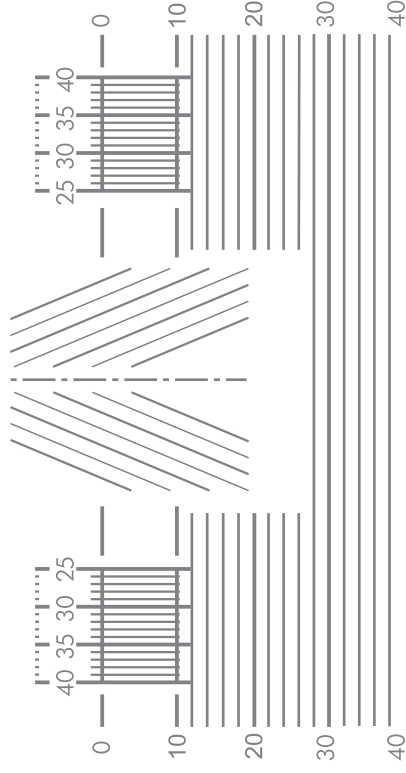
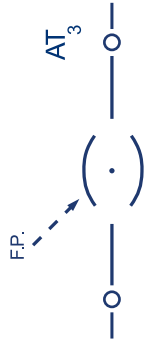

SHAMIR RELAX™

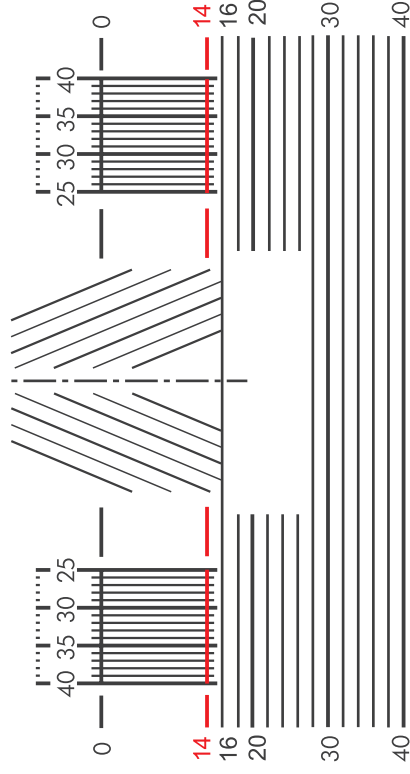

Minimum Fitting Heights: 16mm

SHAMIR SV III AS-WORN™

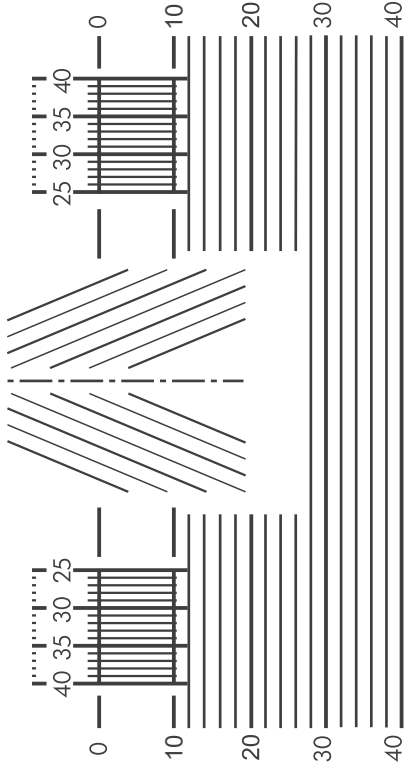
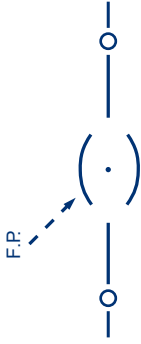

SHAMIR DUO™

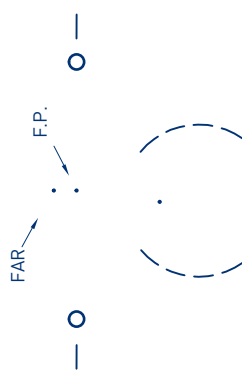
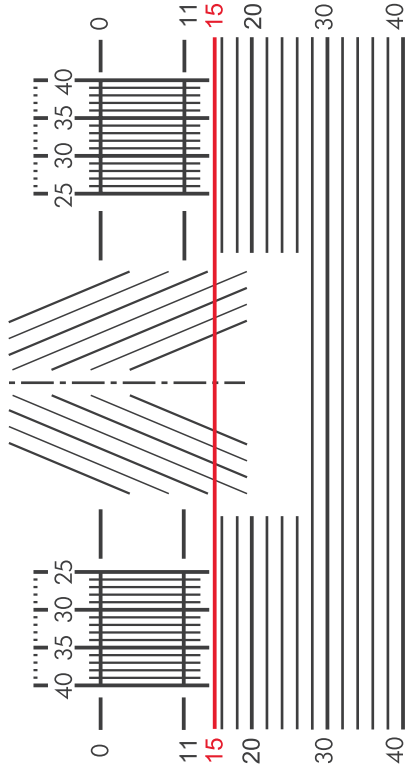
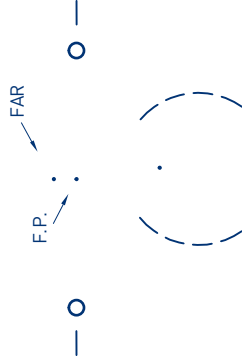

Minimum Fitting Heights: 15mm

Shamir Warranties & Policies

Credits are issued for the following reasons according to our Warranties and policies which are included in the back of the price list and on our website. All credits will be accessed by the Lab to determine if it is a Shamir fault.

The benefits given to you under our express warranty are in addition to other rights and remedies you have under the Australian Consumer Law and other laws. That is, our goods come with guarantees that cannot be excluded under the Australian Consumer Law.

Cancelled Job Policy

- Jobs cancelled prior to surfacing will not be invoiced.
- Cancellation/ credit will not apply to orders that have been processed by Laboratory.

Progressive Lens Warranty

- Warranty claims are accepted for non-adaption, PD adjustment, and heights.
- This warranty does not include power changes.
- This warranty is valid for (3) months from the original invoice date.
- Original lenses will be replaced with an alternative product and a Credit Note will be issued on the lower priced invoiced lenses.
- Credit claims must be accompanied with the appropriate Credit Request Form and original order or copy detailing invoice number, client reference, type of lens, and reason for credit.
- This warranty is applicable for all progressive lenses supplied by Shamir Australia.
- Progressive Lens Warranty does not cover Shamir Vocational Lenses.

Glacier™ Multi-Coat Warranty

- Shamir Australia will replace any Glacier™ Multi-Coat lens product that is deemed faulty by our Quality Control Department.
- This warranty is valid for (2) years from the date of the original invoice.
- Coating of client's own lenses is done on a 'Client's Own Risk' basis.
- Lenses must be returned, accompanied with the appropriate Credit Request Form and original order or copy detailing invoice number, client reference, type of lens, and reason for credit.
- This warranty does not include the mistreatment of lenses.
- If approved, replacement lenses will be supplied in the same prescription, design, index, coating, and frame.

Glacier Plus™ Multi-Coat Warranty

- Shamir Australia will replace any Glacier™ Plus™ Multi-Coat lens products that are deemed faulty by our Quality Control Department.
- This warranty is valid for the lifetime of the lenses from the date of original invoice.
- Coating of client's own lenses is done on a 'Client's Own Risk' basis.
- Lenses must be returned, accompanied with the appropriate Credit Request Form and original order or copy detailing invoice number, client reference, type of lens, and reason for credit.
- This warranty does not include the mistreatment of lenses.
- If approved, replacement lenses will be supplied in the same prescription, design, index, coating, and frame.

Stock Lens Policy

- Shamir Australia will issue a full credit for uncut stock lenses that are returned in original packaging, and in a saleable condition.
- Stock lenses that have been specifically ordered will not be credited.
- Credit Claims must be returned, accompanied with the appropriate Credit Request Form and original order or copy detailing invoice number, client reference, type of lens, and reason for credit.

Grind Lens Policy

- All claims are subject to inspection by our Quality Control Department and credits will only be approved for those products that are deemed to be outside of Australian Standards.
- Credit Claims must be returned, accompanied with the appropriate Credit Request Form and original order or copy detailing invoice number, client reference, type of lens, and reason for credit.
- Grind requests of client's own lenses is done on a 'Client's Own Risk' basis.

Faulty Frames Policy

- Faulty frames detected by our Laboratory will need to be replaced under warranty by the frame manufacturer. Faults include dry solder, screws that are unable to be removed, damaged coating prior to Laboratory handling, etc.
- A frame damaged by Shamir Australia will be replaced on supply of a copy of the frame invoice to the Credit Department.
- Client's own frames are processed on a 'Client's Own Risk' basis.

Rimless Recommendations

- Shamir Australia recommends Tribid® 1.60, DLC Trivec™, 1.60 & 1.67 materials for rimless and nylon rimmed frames.

Tinting Policy

- Shamir Australia will not accept responsibility for matching single lens tints when lenses are being Glacier™ or Glacier Plus™ Multi-Coated.
 - Tinting of client's own lenses are processed on a 'Client's Own Risk' basis.
- ### Edging Policy
- Edging of client's own lenses are processed on a 'Client's Own Risk' basis.

Transitions® Signature™ VII Policy

- Shamir Australia can not guarantee an exact match, if replacing a lens that is not a current generation of Transitions® Signature™ VII.

Transitions® Optical Love Them or Exchange Them

- If your patient does not love their Transitions® lenses, they can be replaced under the Love Them or Exchange Them Guarantee.
- The replacement lenses confirmed under this guarantee varies according to the original pair of Transitions® brand lenses ordered.
- Exchange Transitions® Signature™ VII or Transitions® XTRActive lenses for clear lenses.
- Exchange Transitions® Vantage™ for either Transitions® Signature™ VII or clear lenses.
- Exchange Transitions® Drivewear® for NuPolar® polarised sun lenses.
- For all of the above, ensure exchange is in the same prescription, design, index, coating, and frame within 30 days of receipt of purchase.
- Ensure to write the date of collection on the products corresponding Shamir Transitions® Certificate of Authenticity and provide this to the patient.
- When returning Transitions® lenses, ensure to include a Credit Request Form and original order or copy detailing invoice number, client reference, type of lens, proof of purchase, collections date, and reason for credit.
- To process a return under the Love Them or Exchange Them policy, the customer must return the glasses to the place of purchase and they will receive a replacement static pair in the same prescription, design, index, coating, and frame.

Freight

- A freight charge will apply to all standard deliveries.
- Special deliveries at the customer's request will attract an additional charge.
- Goods being delivered to, or damage occurring during delivery to Shamir Australia, are the senders responsibility.
- Goods being dispatched by Shamir Australia are the responsibility of Shamir Australia.
- This applies to all frames, lenses, and all other products.

Trading Terms

- Payment of invoices are due and payable nett (30) days from end of month, unless otherwise arranged with Shamir Australia Management.
- Failure to meet these payment terms will result in withdrawal of rebates, suspension of supply, and possible initiation of debt collection procedures.
- Credit card payments are strictly (14) days after the receipts of Statement and are free for Visa and Master Card.
- AMEX automatically incurs a 1.25% fee.
- Shamir Australia does not accept Diners Card.
- Payment after (14) days for credit cards will incur all applicable bank charges.

ECP Staff Discounts & Promotional Lenses

Please understand that while we want to ensure our ECP's and their customers have every opportunity to understand our products prior to purchasing them, we enlist these guidelines to ensure fairness for both ECP's, their staff, and for Shamir Australia.

The purpose of this offer is to allow our distribution customers to trial our product and discuss the Shamir lens benefits with customers.

The Shamir Australia Staff Discounts and Complimentary Lens Policy offers:

- Practice owners (1) pair of complimentary lenses per annum including fitting.
- Practice Staff are entitled to a 50% discount on (1) pair of lenses per annum including fitting.

In order to apply for this promotion, ECPs and their staff must return the Promotional Lens Request Form to their corresponding representative for approval prior to making an order.

Approval of these requests are at the discretion of Shamir Australia and their Representatives.

The Shamir Australia ECP Staff Discounts and Complimentary Lens Policy excludes the following items:

- Tinted and polarised sunglasses.
- SV reading glasses.
- Glass Lenses.
- Wrap eyewear.
- Power Mirrors.