



The Aquafil Hydrofil is our largest wall-mounted bottle filling station.

The product features four anti-bacterial bottle refill points with optional inbuilt filters. The station can be used as a stand-alone bottle filling unit or can be installed on top of an existing trough. Its durability and function make the Aquafil Hydrofil an ideal solution for school campuses and busy sporting complexes.

Product Features

- Four anti-bacterial bottle filling points
- HDPE safety edge end panels
- Vandal-resistant stainless steel buttons
- Heavy duty stainless steel housing construction
- Heavy duty vandal-resistant stainless steel refill nozzles



WaterMark Certified (Certificate number: 023305)

The WaterMark Certification Scheme (Scheme) is a mandatory certification scheme for plumbing and drainage products to ensure they are fit for purpose and appropriately authorised for use in plumbing and drainage installations.

Technical Details

Housing frame	Stainless steel
Housing unit	Stainless steel
End panels	Light grey HDPE
Filter unit option	Sub micron or 5 micron (2 per unit)
Filter unit working pressure	Minimum 100kpa
Water supply connection	Water supply inlet 1/2" BSP male
Drainage	This product does not come with drainage
Weight	30kg
Flow rate	Minimum 12 litres per minute

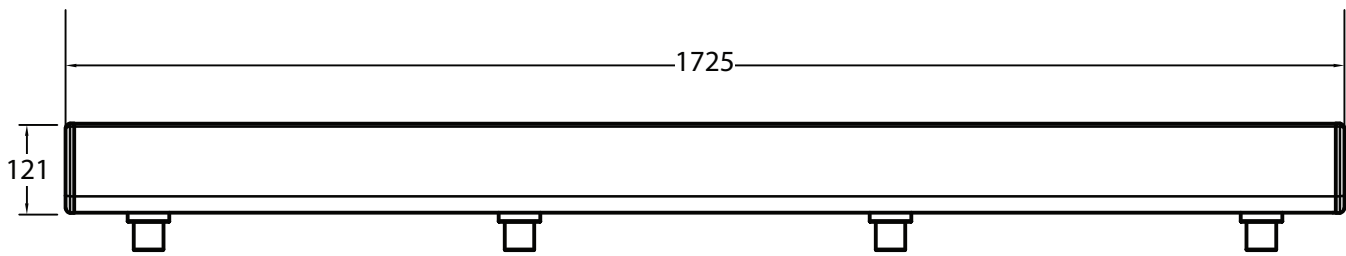
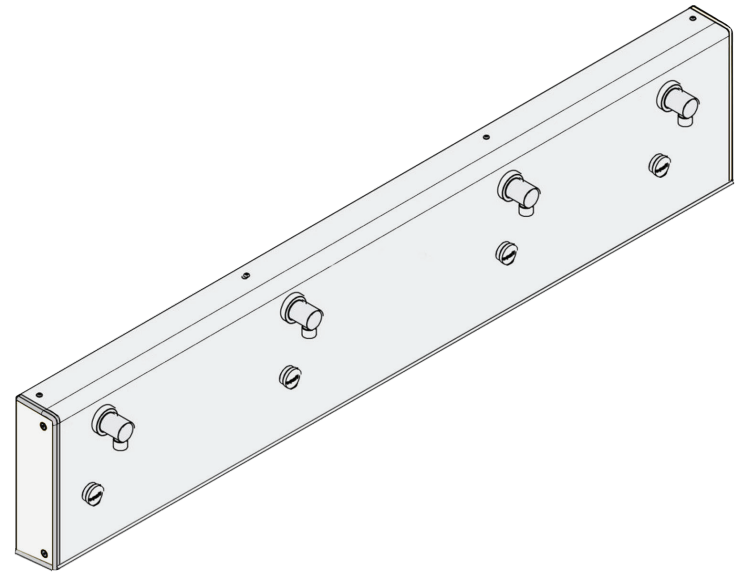

Top View

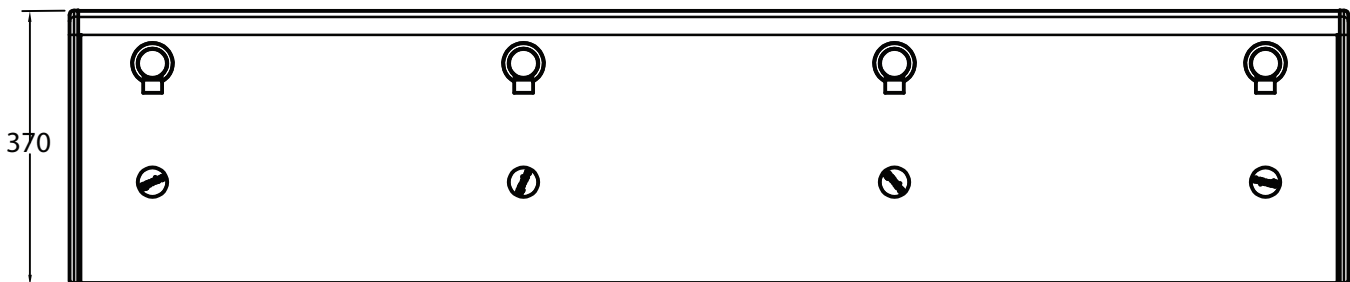

Front View