



Pictured: Aquafil Pulse Senior 1400BF, Melbourne Sports and Aquatic Centre (VIC)

The Aquafil Pulse Senior drinking fountain and bottle refill station is a robust, economical solution especially popular in senior schools.

The station features two anti-bacterial bottle refill nozzles and a stainless steel drinking fountain, with the added option of an inbuilt filter. Customisable, vandal-resistant signage panels allow for educational artwork to be featured on the exterior, making the station an attractive element in school landscapes.

Product features

- 1400mm height
- Two anti-bacterial bottle refill points
- Internal drainage, allowing for indoor or outdoor installation
- DDA-compliant wheelchair-accessible design
- Soft mouth guard fitted to drinking fountain
- Customisable graphic panels with anti-graffiti protection
- Removable panel for easy filter replacement
- Two year warranty*

Additional options

- Optional inbuilt water filter
- Optional inbuilt water meter
- Optional remote water chiller

Technical Details

Housing frame	Stainless steel
Housing unit	Anodised aluminium
Graphic panels	Stainless steel
Filter unit	Sub-micron or 5 micron
Filter unit working pressure	10-125 psi (0.7-8.5 bar), non-shock
Water supply connection	1/2 inch supply line with 1/2 inch Male BSP connection
Drainage	50mm PVC

*Please refer to the Aquafil® Product Warranty for full terms and conditions

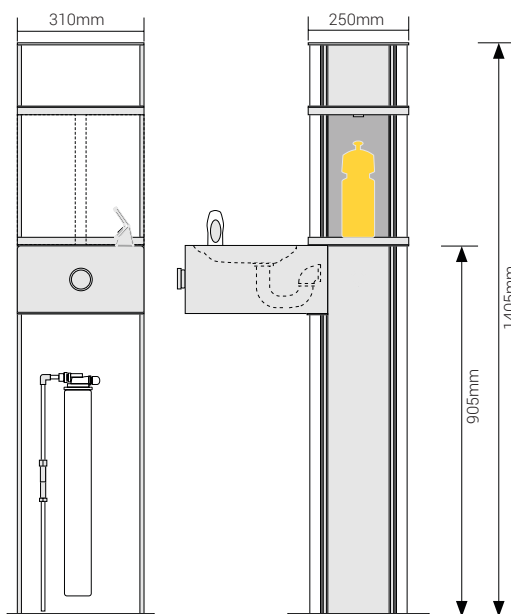
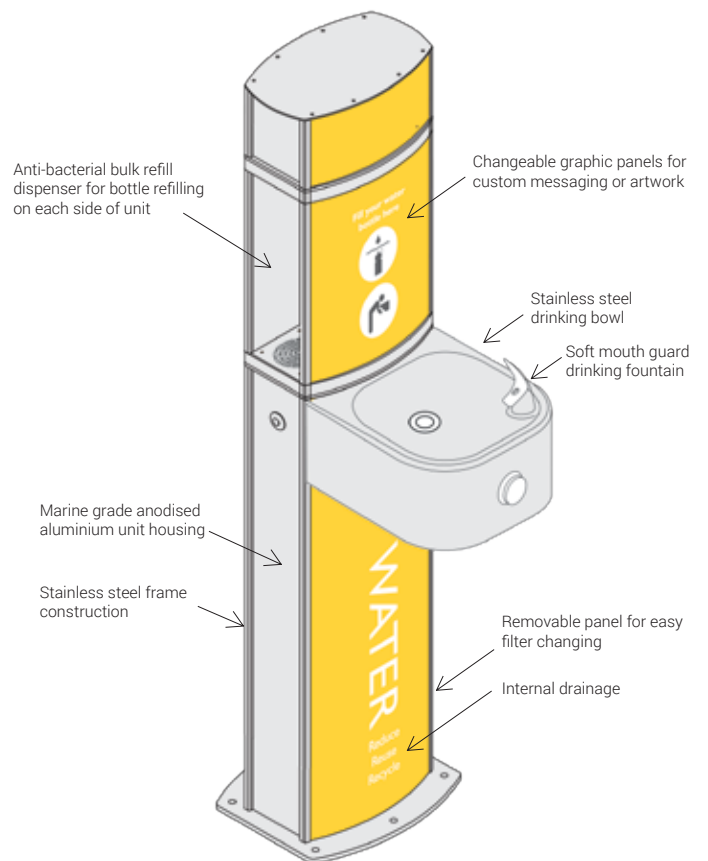

Front & Side view with filter detail

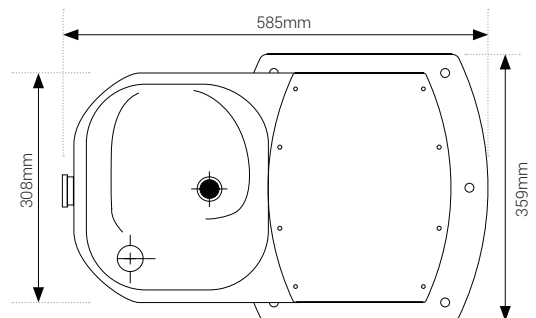

Top View