

Where is the Kotzur difference?	KEOGH AG250/13.7m/415V	KBSH300/13.7m/415V
Unloading TPH (Tonnes per Hour)	80—100	150
Sweep drive permanently wired and switched from outside (No need to carry a power lead in to operate sweep)	✗	✓
Sweep pivots on a machined turntable	✗	✓
Sweep drive features an underfloor motor, heavy duty Flexible Jaw Coupling and a Bevel Helical Gearbox	✗	✓
Inlets	One in the centre plus two intermediates over top	One in centre plus two over-sized intermediates offset
Underfloor 50mm pipe Access to the main outlet	✗	✓
Grain inlets to under floor auger have controlled pitched flight	✗	✓
Inlet gates move on ball bearings to allow for easy operation	✗	✓
Slide gate operation via large diameter, rack and pinion hand Wheel	✗	✓
Unique design to eliminate opening of intermediate gates until centre gate is fully open	✗	✓
Oscillating drive to sweep wheel—positive traction	✗	✓
Non-slip wheel to minimize tyre wear / damage to silo floor	✓	✓
Spring controlled forward speed automatically adjusts to regulate grain volume	✗	✓
Weighted to provide consistent traction	✗	✓
All external components hot dipped galvanised for durability	✓	✓
Adjustable height sweep	✓	✓
Flexible wiper to minimise remaining grain	✗	✓
Suitable for Gas Sealed Silos	✓	✓
Sight glass at incline transition	✓	✓
Lockable with a padlock	✓	✓
Freight ex-Qld manufacturing site to Walla(trailer load)	4	3
Price ex-Walla	\$22,725	\$33,478



KOTZUR

SILO UNLOADER OPTIONS

KBSH 300/13.7m/415V

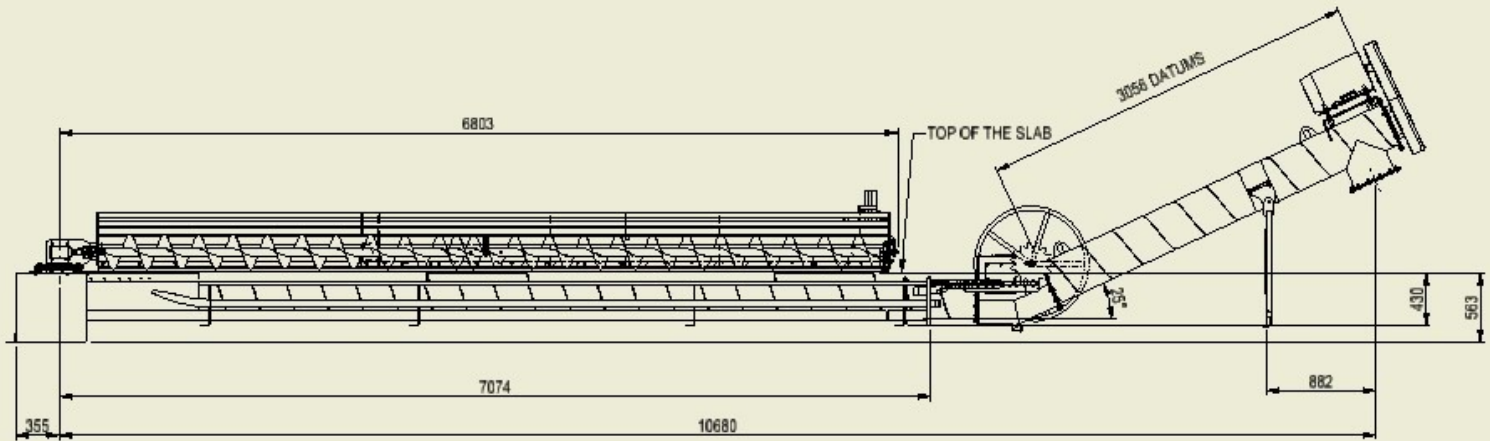

KEOGH AG250/13.7m/415V

