



The Aquafil Pulse Senior dual-height drinking fountain and bottle refill station is a robust, economical solution designed specially for middle and senior school spaces with high foot traffic.

The station features two anti-bacterial bottle refill nozzles and two drinking fountains, each offset at a different height. Customisable, vandal-resistant signage panels allow for educational artwork to be presented on the exterior, making the station an attractive element in schools and public places.

Product features

- 1400mm height
- Two anti-bacterial bottle refill points
- Two x drinking fountains
- Soft mouth guard fitted to drinking fountain
- Customisable graphic panels with anti-graffiti protection
- Removable panel for easy filter replacement
- Two year warranty*

Additional options

- Optional inbuilt water filter
- Optional remote water chiller
- Optional extra-deep wheelchair-accessible drinking fountain basin
- Optional extra heavy-duty drinking fountain guard
- Optional inbuilt water meter
- Optional remote chiller with housing for outdoor installations

Technical Details

Housing frame	Stainless steel
Housing unit	Anodised aluminium
Graphic panels	Stainless steel
Filter unit option	Sub-micron or 5 micron
Filter unit working pressure	10-125 psi (0.7-8.5 bar), non-shock
Water supply connection	1/2 inch supply line with 1/2 inch Male BSP connection
Drainage	40mm PVC

*Please refer to the Aquafil® Product Warranty for full terms and conditions

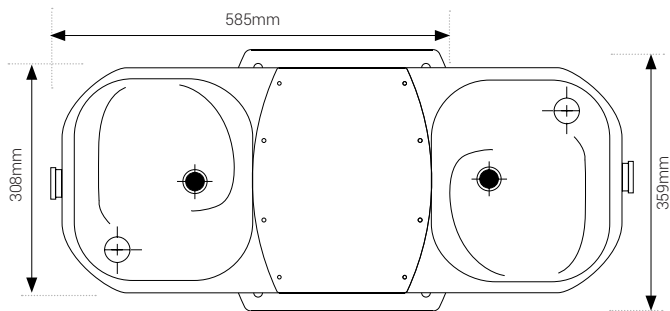
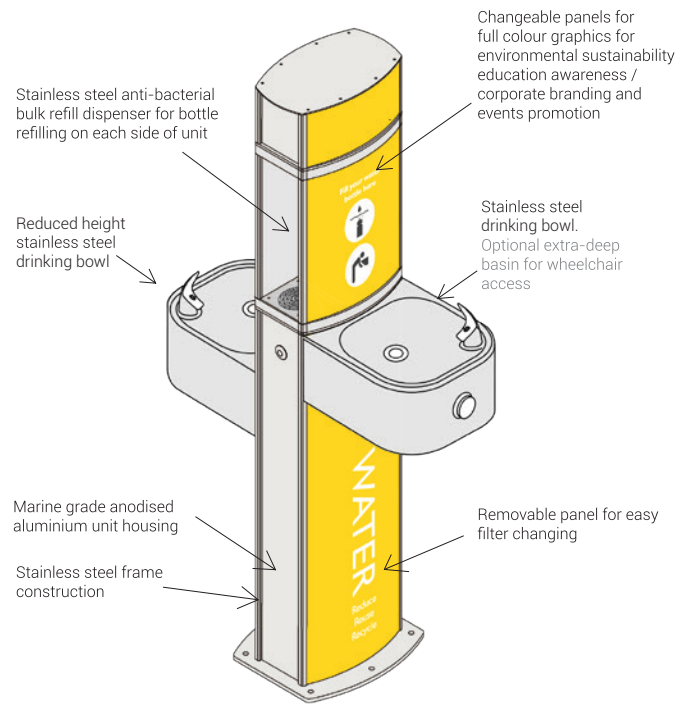

Top View

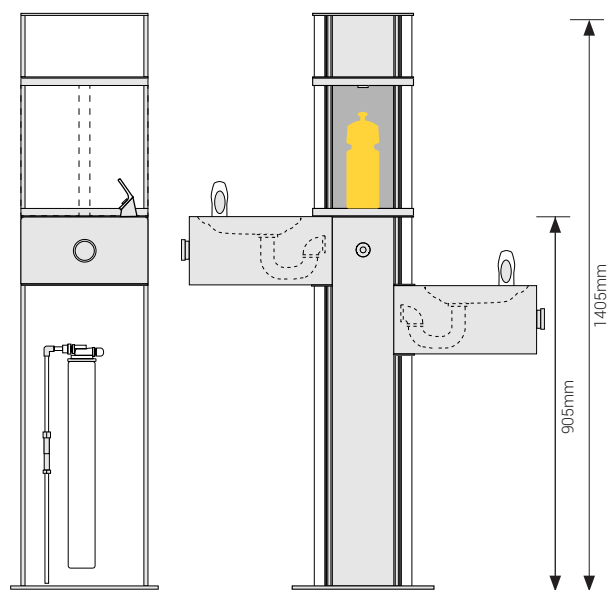

Front & Side view with filter detail