

Volumetric Feeders

Material Handling Excellence



Take a Closer Look at the Best in Volumetric Feeders.

Tecweigh® Volumetric Feeders offer unsurpassed performance through a simple, yet effective design.

Tecweigh is a leading designer and manufacturer of in-motion weighing and metering products for dry material handling applications in the food, chemical, plastics, mining, and construction aggregates industries.

The polyurethane FLEX-FEED® hopper is stronger, more resilient and abrasion-resistant than vinyl. No cracks or ledges exist to collect material. The hopper interlocks with the cabinet for a tight seal. The patented auger and feed-tube designs allow for quick, tool-less removal and re-assembly.

Tecweigh feeders are flexible enough to accommodate a wide variety of dry materials, from fine powders to large pellets. Our three different sizes of feeders can move from .003 cu. ft. /hour to more than 900 cu. ft. /hour.

Superior Line of Feeding and Weighing Systems

Tecweigh weighing systems offer special options to meet your specific needs, such as:

- Extension hoppers
- Custom augers and feedtubes
- Spreader attachments
- Custom controls
- Loss/Gain-in-weight units
- Batching units

Flex-Feed® Hopper

- Industrial grade
- Food grade
- Chemical resistant

Agitation Paddles

- Heavy duty stainless steel welded construction
- Unique design minimizes hopper wear
- Sealed roller bearings on paddle shafts

Drive Assembly

- Oversized roller chain drive
- Automatic chain tensioner
- Stainless steel drive components (optional)
- Cog belt drive (optional)

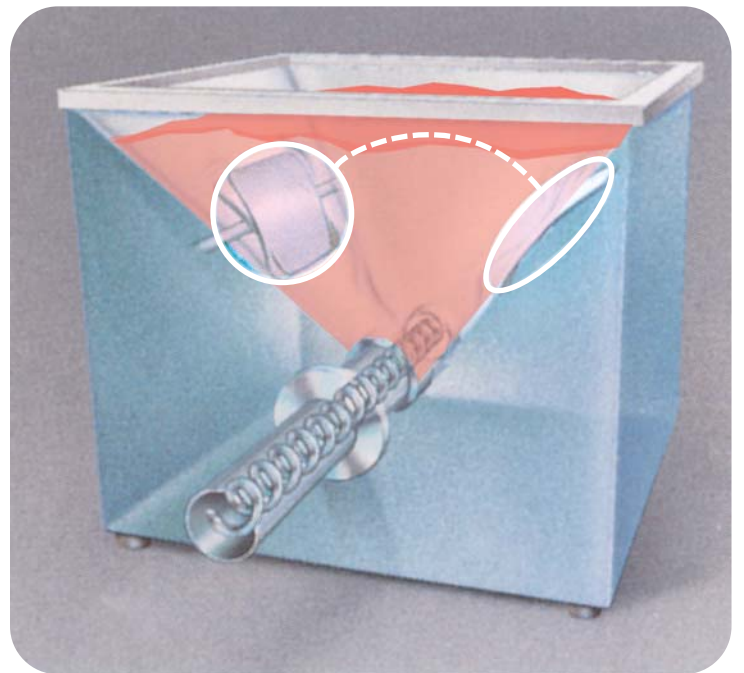

Diagram shows how continuous motion of the paddles on both sides of the hopper allows the agitation system to eliminate product degradation, rat-holing, bridging and compacting while handling the most difficult materials.



Tool-less disassembly provides easy inspection, maintenance, and repair. Quickest disassembly and reassembly in the industry.

Controls

- NEMA 4 control enclosure
- SCR drive, 40:1 turndown ratio
- Digital potentiometer
- Illuminated On/Off switch
- Remote interlock
- 120 VAC input power

Options continued

- Fast/Dribble SCR drives
- Remote set point
- Batch controllers
- Loss/Gain-in-weight controllers
- 220 VAC input power
- Custom feedtubes
- Special finishes
- Inverter duty rated motors
- Explosion proof motors
- Wash down/Chemical duty motors

Fast Assembly and Disconnect

- Quick disconnect design auger and feed tube
- Patented cartridge drive bearing assembly

Options Available

- Independent paddle speed control
- Tach feedback
- 4-20 ma speed indication output signal
- 316 stainless steel
- 100% stainless steel construction
- Extension hoppers and covers
- NEMA 4X or explosion proof (NEMA 7/9) enclosures

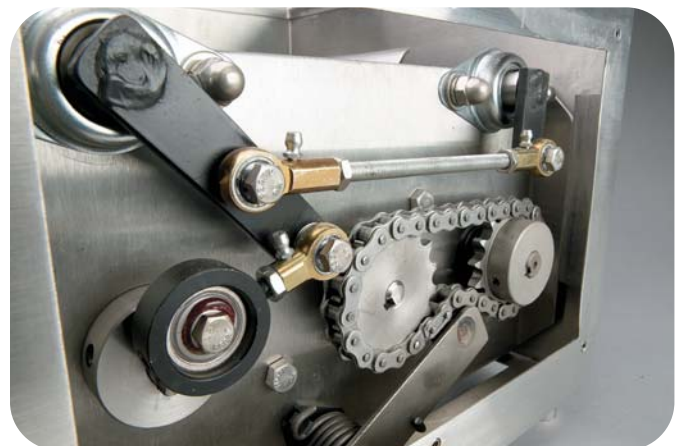

Detail shows solid construction and high quality hardware for years of dependable service.

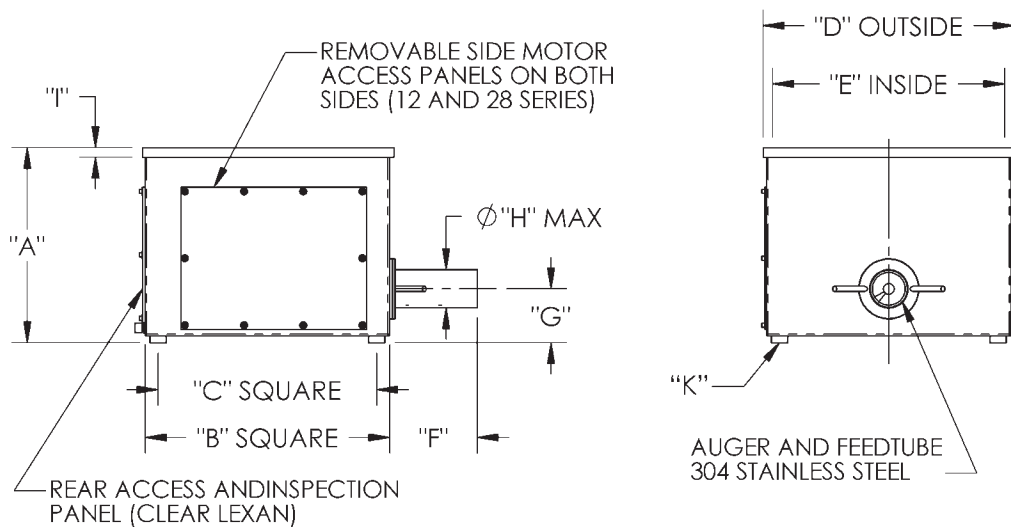

DIMENSION DATA (INCHES)										
MODEL	A	B	C	D	E	F	G	H	I	K
05 SERIES	12.38	14.00	12.00	14.25	13.00	6.00	4.38	1.50	0.50	3/8-16
12 SERIES	17.88	22.38	20.00	23.00	21.25	8.00	4.95	3.50	0.88	1/2-13
28 SERIES	25.00	28.94	27.00	29.75	27.75	8.00	7.82	6.63	1.00	1/2-13

TECHNICAL DATA				
MODEL	STANDARD MOTOR HP†	MAXIMUM RATE CAPACITY	UNIT WEIGHT*	HELIX SIZES AVAILABLE
05 SERIES	1/8 HP	7 CUBIC FEET PER HR	50 LBS	1/4" - 1-1/4"
12 SERIES	1/2 HP	100 CUBIC FEET PER HR	150 LBS	1-1/2" - 3"
28 SERIES	1 HP	900 CUBIC FEET PER HR	350 LBS	4" - 6"

† - LARGER HP MOTORS ARE AVAILABLE PER APPLICATION

* - WEIGHT GIVEN, IS FOR SINGLE DRIVE UNITS WITH A STANDARD MOTOR
DUAL DRIVE UNITS AND SPECIAL MOTORS WILL INCREASE WEIGHT

MATERIALS OF CONSTRUCTION			
COMPONENT	"E" SERIES	"CR" SERIES	"S" SERIES [⌘]
CABINET	MILD STEEL COATED WITH OVEN BAKED TGIC POLYESTER	304 STAINLESS STEEL #4 FINISH EXTERIOR 2B FINISH INTERIOR	304 STAINLESS STEEL #4 FINISH EXTERIOR 2B FINISH INTERIOR
CHASSIS	G90 GALVANIZED	G90 GALVANIZED	304 STAINLESS STEEL 2B FINISH

⌘ - WASHDOWN MODELS AVAILABLE

For more information on these and other Tecweigh products visit our web site at www.tecweigh.com.au



Supplier of choice for in-motion weighing & metering solutions

Factory 3, Silkwood Business Park
7, Lakewood Boulevard
Carrum Downs VIC 3201

Ph: +613 9775 0266

Fax: +613 9775 0966

E-mail: sales@tecweigh.com.au

Web: www.tecweigh.com.au