



**MODERN TRANSPORT
ENGINEERS AUSTRALIA**
Pty Ltd

TRAILER CATALOGUE

07 3393 5100 | office@modtrans.com.au | 15 Millennium Place, Tingalpa QLD 4173



STATE OF THE ART TRAILERS

Manufacturers of Heavy Transport trailers since 1973, Modern Transport Engineers manufactures trailers that are internationally renowned for their quality, reliability and durability.

With Modern Transport Engineers, you gain access to generations of experience in the heavy transport industry and a complete range of manufacturing facilities and services, spare parts sales and service, engineering services and design expertise.

Manufacturing

Engineered for efficiency and productivity, our Trailers are designed and manufactured with the highest quality materials to suit the toughest conditions.



Latest technology

MTE has a commitment to deliver world class quality products using only the newest and safest technology available. From safety to efficiency MTE is at the forefront.

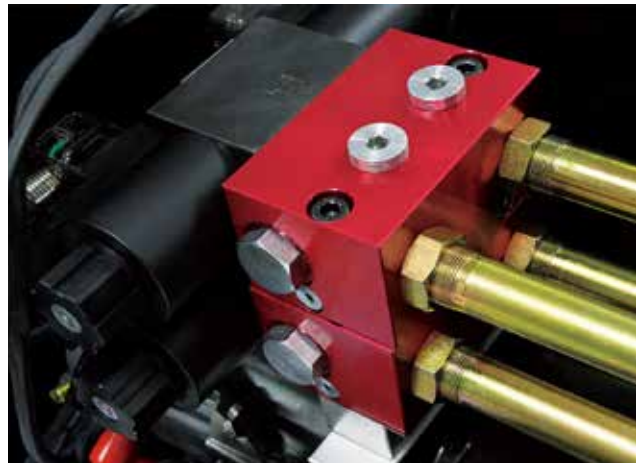

Operator training

Increase productivity by learning how to operate your trailer in the most efficient way. MTE Offers training which encompasses the best practices in the industry.



Here to support you

Full product support and spare parts network servicing New Zealand and Australia, with over 16,000 line items in stock at any time.



A CLASS OF ITS OWN

In an industry that is always evolving, with growing business demands, customers need a Trailer that they can rely on. As an asset to your operation, MTE Trailers run innovative technologies bringing you quality as standard.



MODERN TRANSPORT ENGINEERS

Transport Leaders For Over 50 Years

Since introducing its first Transport Trailer, MTE has continued to lead the way in transport innovation for over 50 years.

1973

Modern Transport Engineers is Founded by Robin Ratcliffe.

1974

First Transporter Trailer rolls off the MTE production line.

1980

First House Trailer of its kind.

2000

MTW is opened to supply parts and accessories for all MTE Trailers.

2002

Zane & Mike Ratcliffe take over joint ownership of MTE.

INTRODUCTION



2006

MTE opens its first Australian branch in Brisbane.

2011

MTE builds its biggest ever trailer with a capacity of over 650 tonne.

2012

MTE purchases The Waikato Times site and expands operations.

2018

First use of the Smart Trailer App on a MTE Tipper Truck & Trailer.

2019

MTE Develops new Pushoff Technology to replace standard Tipper.

2023

MTE celebrates 50 years in business.



CONTENTS

| | |
|-----------------------|-------|
| INTRODUCTION | 2-4 |
| LINKWINGS | 8-15 |
| DOLLYS | 16-19 |
| JINKERS | 20-23 |
| BEAMSETS | 24-25 |
| ROWS OF 4 LOW LOADERS | 26-45 |
| TILT DECKS | 46-49 |
| TRIPLE EXTENDABLES | 50-55 |
| B-TRAINS | 56-57 |
| SIMPLE TRAILERS | 58-59 |
| FLAT TOP LOW LOADERS | 60-65 |
| TIPPERS | 66-67 |
| BOAT TRANSPORTERS | 68-69 |
| PANEL TRAILERS | 70-71 |
| HOUSE TRAILERS | 72-73 |
| JACKING PLANTS | 74-76 |

LIGHT-WEIGHT 3 ROWS OF 8 LINKWING

The Light-Weight 3 Rows of 8 Linkwing is the lightest Linkwing available. specifically designed with increased manoeuvrability and payload capacity you can deliver to more places than ever before. The lightweight Linkwing saves on Tare weight which gives a capacity of up to 60,000kg GVM.

DRAWINGS

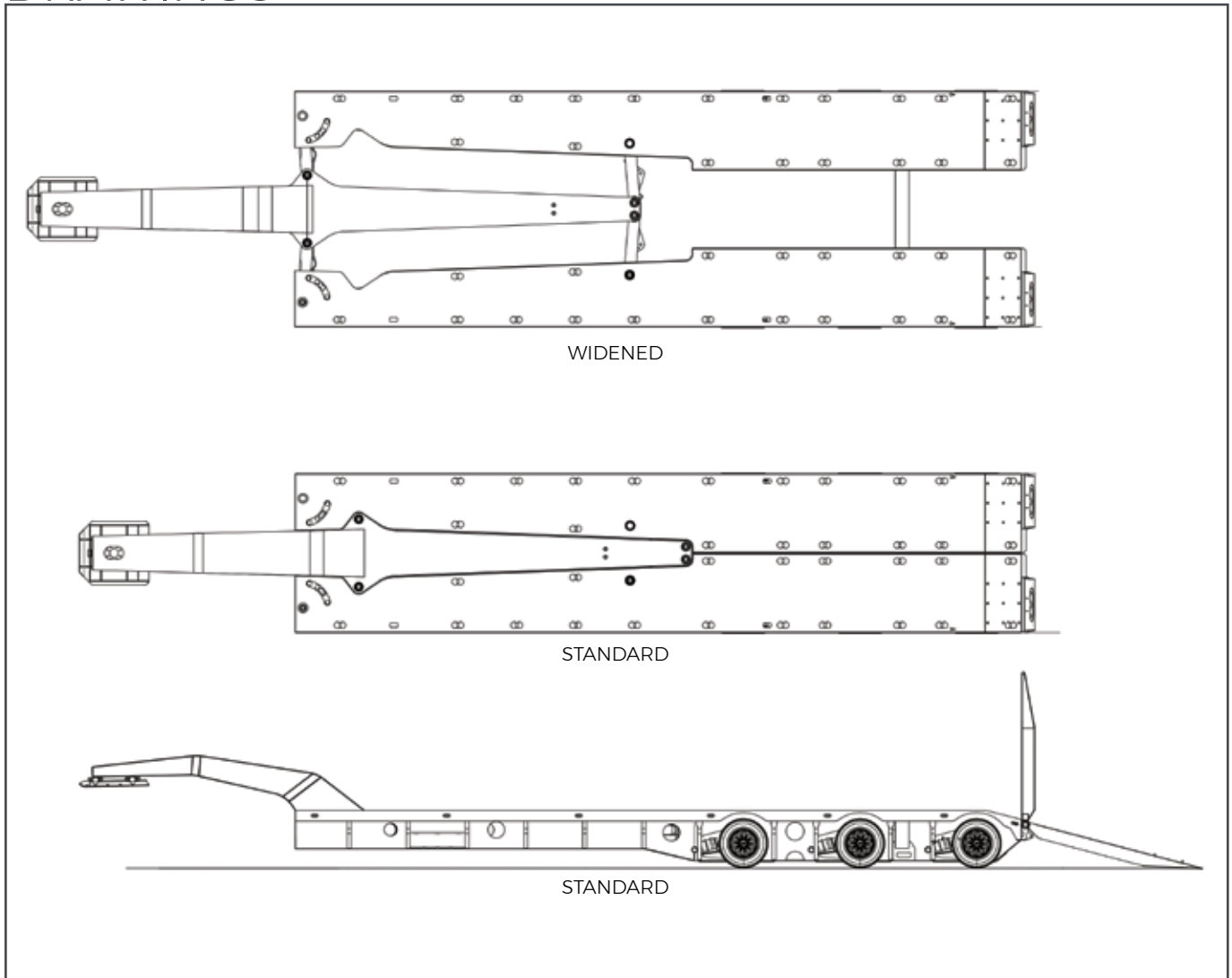

SPECIFICATIONS

| STANDARD SPECIFICATIONS (APPROX) | |
|----------------------------------|---|
| GVM | 55,000kg |
| Deck Length (Overall) | 11390mm |
| Deck Length (Behind G/N) | 10300mm |
| Deck Height | 900mm |
| Widening | 2500mm closed - 3700mm open |
| Opening Widths | 2500mm, 3100mm, 3400mm, and 3700mm |
| Axles | MTE 17.5" Ten Stud 225 PCD |
| Axle Spacing | 1830mm - 1830mm |
| Axle Retraction | Axle Retraction all axles to facilitate maintenance |
| Suspension | MTE Hydraulic suspension with NEW low maintenance quick change rams |

SPECIFICATIONS

| STANDARD SPECIFICATIONS (APPROX) | |
|----------------------------------|---|
| Brakes | 1/4" x 5-1/2" Brakes on outboard drums |
| Tyres | 215/75R x 17.5" |
| Wheels | Steel wheels |
| Spare Tyre Carriers | 2 |
| Power Source | Truck |
| Lighting | LED lights to ADR 4198 with 1 Rotating light in ramp |
| Rub Plate | One position oscillating rub plate |
| Gooseneck | Fixed height |
| King Pin | 3-1/2" MTE Drop-in king pin |
| Ramps | 2400mm x 900mm hydraulic |
| Toolboxes | Two open toolboxes on each side of trailer |
| Chain Bins | Two chain bins on spine of trailer |
| Link Pins | 150mm diameter front link pins - 100mm diameter rear link pins |
| Signage | "Do not overtake" and sliding "OVERSIZE" |
| Landing Legs | Heavy duty |
| Deck Material | High tensile 790mpa steel construction with a fully enclosed deck |

OPTIONAL EXTRAS

| OPTIONAL EXTRAS (APPROX) | |
|--------------------------|---|
| Wheels | Aluminium Wheels Machined Finish (12.8kg / Wheel) |
| Wheels | Aluminium Wheels Polished Finish (12.8kg / Wheel) |
| Tyres | Specific branded tyres. (Please State) |
| Ramps | Double Fold Ramps 3700mm x 900mm |
| Greasing | Centralised greasing - brakes and suspension |
| Greasing | Centralised greasing with timer - brakes and suspension |
| Greasing | Manual Greasing system 8 points per suspension out to a manual block |
| Remote Control | 10 Function Remote system for operating Suspension & Widening |
| Ship Locks | Ship-lock pockets for 20' and 40' containers & 4x double ended ship locks |
| Signage | Folding "OVERSIZE" signs |
| Power Pack | 5.5 HP Diesel power pack, electric start with battery |
| Power Pack | 5.5 HP Petrol power pack, pull start only |
| Power Pack | 5.5 HP Petrol power pack, electric start with battery |
| Guages | Gauges for load indication |
| Storage | 6x Lockable Toolboxes (3 on each side) |
| Water Tank | Stainless steel water tank and Tap |
| King Pin | MTE 50mm Drop in Kingpin |
| Odometer | Hub Odometer |

3 ROWS OF 8 LINKWING

The 3 Rows of 8 Linkwing is our most popular trailer. With an 80,000kg GVW, hydraulic widening and hydraulic suspension. It has the added bonus of being able to clip on more rows of 8 to handle any job. The Linkwing can raise, lower, widen its decks and can be optioned with a internal hydraulic gooseneck. The linkwing is fully customisable to meet your individual transport needs.

DRAWINGS

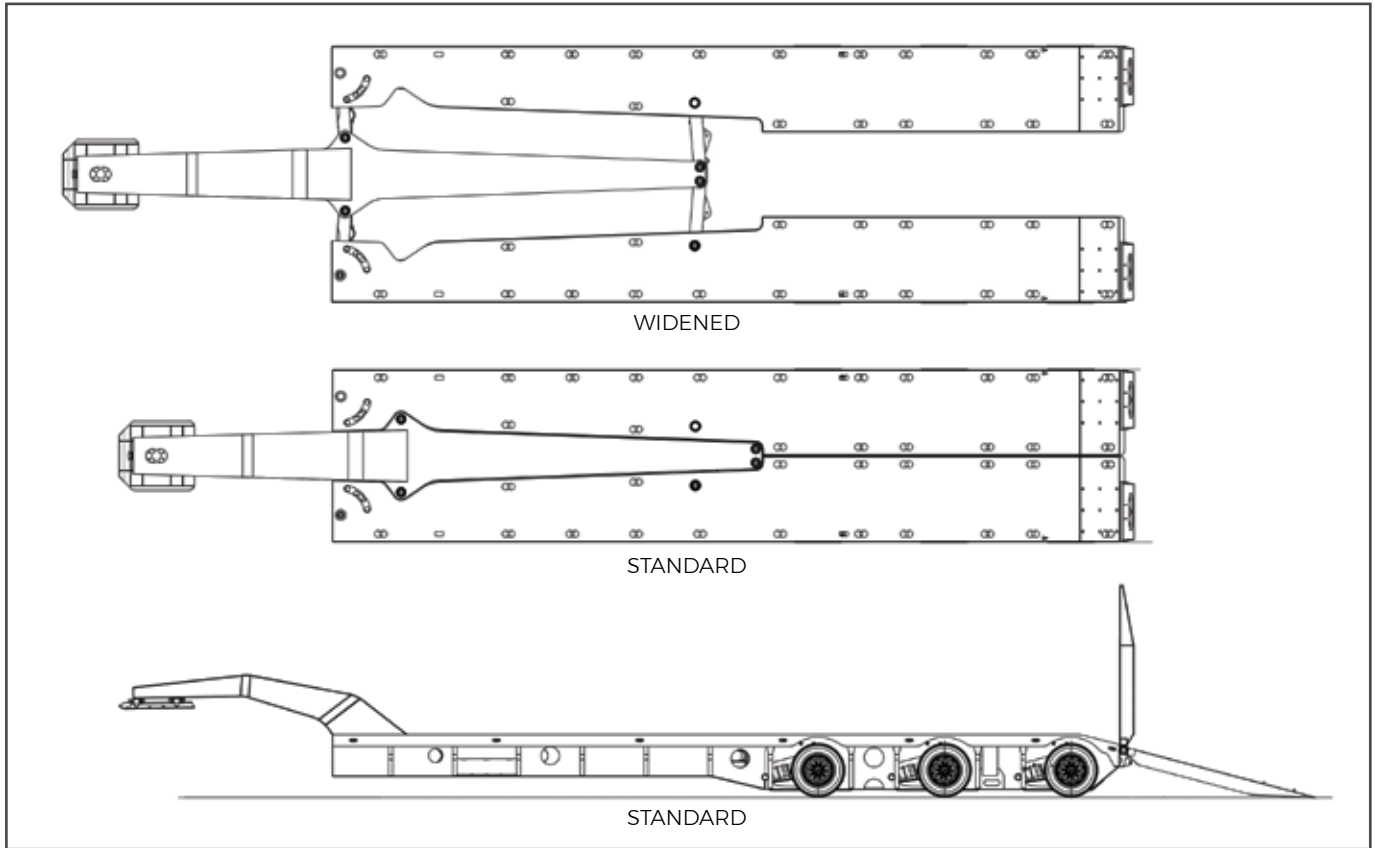

SPECIFICATIONS

| STANDARD SPECIFICATIONS (APPROX) | |
|----------------------------------|---|
| GVM | 80,000kg |
| Deck Length | 10800mm |
| Deck Height | 900mm |
| Widening | 2500mm closed - 4270mm open |
| Opening Widths | 2500mm, 2700mm, 3100mm, 3500mm, 3750mm, 4000mm, and 4270mm |
| Axles | MTE 17.5" Ten Stud 225 PCD |
| Axle Spacing | 1830mm - 1830mm |
| Axle Retraction | Axle Retraction to all axles to facilitate maintenance |
| Suspension | MTE Hydraulic suspension with NEW low maintenance quick change rams |
| Brakes | 12-1/4" x 5-1/2" brakes on outboard drums |
| Tyres | 215 x 17.5" 16ply |
| Wheels | Steel wheels |
| Spare Tyre Carriers | 2 |
| Power Source | Truck |
| Lighting | LED lights to ADR 4198 with 1 Rotating light in ramp |

SPECIFICATIONS

| STANDARD SPECIFICATIONS (APPROX) | |
|----------------------------------|--|
| Rub Plate | Two-position oscillating |
| Rub Plate Height | 1300mm |
| Gooseneck | Fixed Height |
| King Pin | 3-1/2" MTE drop-in king pin |
| Ramps | 2700mm x 900 Hydraulic |
| Toolboxes | Two open toolboxes on each side of trailer |
| Chain Bins | Two chain bins on spine of trailer |
| Link Pins | 150mm diameter front link pins - 100mm diameter rear link pins |
| Signage | "Do not overtake" and "OVERSIZE" |
| Landing Legs | Heavy Duty |
| Deck Material | Western Australia Heavy Duty with two x wear straps on neck, 10mm thick deck |

OPTIONAL EXTRAS

| OPTIONAL EXTRAS (APPROX) | |
|--------------------------|---|
| Wheels | Aluminium Wheels Machined Finish (12.8kg / Wheel) |
| Wheels | Aluminium Wheels Polished Finish (12.8kg / Wheel) |
| Tyres | Specific branded tyres. (Please State) |
| Ramps | Heavy duty Ramps 1050mm x 3000mm |
| Ramps | Double Fold Ramps 3700mm x 900mm |
| Ramps | Double Fold Ramps 4400mm x 900mm |
| Greasing | Centralised greasing - brakes and suspension |
| Greasing | Centralised greasing with Timer - brakes and suspension |
| Greasing | Manual Greasing system 8 points per suspension out to a manual block |
| Remote Control | 12 Function Remote system for operating Gooseneck, Suspension & Widening |
| Ship Locks | Ship-lock pockets for 20' and 40' containers & 4x double-ended ship locks |
| Power Pack | 5.5 HP Diesel power pack, electric start with battery |
| Power Pack | 5.5 HP Petrol power pack, pull start only |
| Power Pack | 5.5 HP Petrol power pack, electric start with battery |
| Gauges | Gauges for load indication |
| Storage | 6x Lockable Toolboxes (3 on each side) |
| Water Tank | Stainless steel water tank and Tap |
| Rub Plate | Sliding rub plate |
| Gooseneck | Hydraulically adjustable compensating gooseneck |
| King Pin | MTE 50mm Drop in Kingpin |
| Odometer | Hub odometer |
| Deck | Longer Deck - 11900mm Deck Length |
| Deck | Longer Deck - 12550mm Deck Length |
| Extendable | Extendable - 3-Meter extension with 12,540mm Overall Deck length. (Extends in 500mm increments) |
| Extendable | Extendable - 4-Meter extension with 13,550mm Overall Deck length. (Extends in 500mm increments) |
| Clip On | Clip-on 4th axle |
| Drop Bed | 125mm |
| Widening | Cylinder on Spine to assist widening |

4 ROWS OF 8 LINKWING

The 4 Rows of 8 Linkwing is one of our larger trailers. With an 110,000kg GVW, hydraulic widening and hydraulic suspension. It has the added bonus of being able to be optioned with a drop bed. The Linkwing can raise, lower, widen its decks and can be optioned with an internal hydraulic gooseneck. The linkwing is fully customisable to meet your individual transport needs.

DRAWINGS

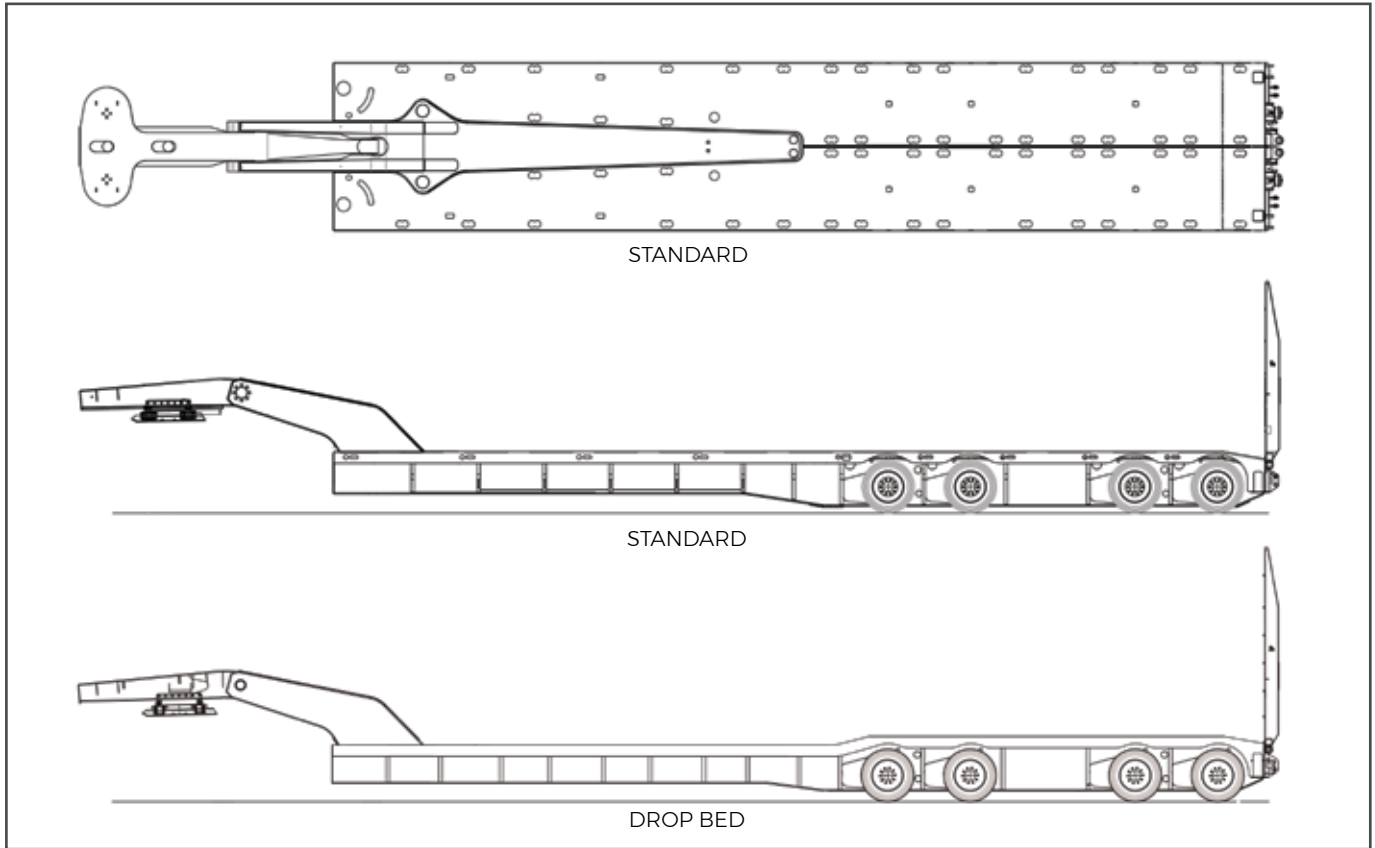

SPECIFICATIONS

| STANDARD SPECIFICATIONS (APPROX) | |
|----------------------------------|--|
| GVM | 110,000kg |
| Deck Length (Overall) | 13807mm |
| Deck Length (Behind C/N) | 12475mm |
| Deck Height | 900mm |
| Widening | 2500mm closed - 4270mm open |
| Opening Widths | 2500mm, 2700mm, 3100mm, 3500mm, 3750mm, 4000mm, and 4270mm |
| Axles | MTE 17.5" ten stud 225 PCD |
| Axle Spacing | 1220mm - 2440mm - 1220mm |
| Axle Retraction | Axle Retraction to all axles to facilitate maintenance |
| Suspension | Hydraulic suspension with NEW low maintenance quick change rams. |
| Brakes | 12-1/4" x 5-1/2" brakes with outboard drums |
| Greasing | Manual Greasing system 8 points per suspension out to a manual greasing block. |
| Tyres | 215 x 17.5" |
| Wheels | Steel wheels. |
| Spare Tyre Carriers | 2 |

SPECIFICATIONS

| STANDARD SPECIFICATIONS (APPROX) | |
|----------------------------------|--|
| Lighting | LED lights to ADR 4198 with 1 Rotating light in ramp |
| Rub Plate | Two Position Oscillating |
| Rub Plate Height | 1300mm |
| King Pin | 3-1/2" king pin |
| Ramps | 3300mm x 1050mm Hydraulic with run-flat ramp stays |
| Toolboxes | 8x Open toolboxes (4x on each side of trailer) |
| Chain Bins | Two chain bins on spine of trailer |
| Link Pins | 150mm diameter front link pins - 100mm diameter rear link pins |
| Signage | "Do not overtake" and "OVERSIZE" |
| Landing Legs | Heavy Duty |
| Deck Material | Western Australia Heavy Duty with two x wear straps on neck, 10mm thick deck and 70mm camber |

OPTIONAL EXTRAS

| OPTIONAL EXTRAS (APPROX) | |
|--------------------------|---|
| Wheels | Aluminium Wheels Machined Finish (12.8kg / Wheel) |
| Wheels | Aluminium Wheels Polished Finish (12.8kg / Wheel) |
| Tyres | Specific branded tyres. (Please State) |
| Ramps | Heavy duty Ramps 1050mm x 3000mm |
| Ramps | Double Fold Ramps 3700mm x 900mm |
| Ramps | Double Fold Ramps 4400mm x 900mm |
| Greasing | Centralised greasing - brakes and suspension |
| Greasing | Centralised greasing with Timer - brakes and suspension |
| Greasing | Manual Greasing system 8 points per suspension out to a manual block |
| Remote Control | 12 Function Remote system for operating Gooseneck, Suspension & Widening |
| Ship Locks | Ship-lock pockets for 20' and 40' containers & 4x double-ended ship locks |
| Power Pack | 5.5 HP Diesel power pack, electric start with battery |
| Power Pack | 5.5 HP Petrol power pack, pull start only |
| Power Pack | 5.5 HP Petrol power pack, electric start with battery |
| Gauges | Gauges for load indication |
| Storage | 6x Lockable Toolboxes (3 on each side) |
| Water Tank | Stainless steel water tank and Tap |
| Rub Plate | Sliding rub plate |
| Gooseneck | Hydraulically adjustable compensating gooseneck |
| King Pin | MTE 50mm Drop in Kingpin |
| Odometer | Hub odometer |
| Deck | Longer Deck - 11900mm Deck Length |
| Deck | Longer Deck - 12550mm Deck Length |
| Extendable | Extendable - 3-Meter extension with 12,540mm Overall Deck length. (Extends in 500mm increments) |
| Extendable | Extendable - 4-Meter extension with 13,550mm Overall Deck length. (Extends in 500mm increments) |
| Clip On | Clip-on 4th axle |
| Drop Bed | 125mm |
| Widening | Cylinder on Spine to assist widening |

5 ROWS OF 8 LINKWING

The 5 Rows of 8 Linkwing is one of our larger trailers. With an 110,000kg GVW, hydraulic widening and hydraulic suspension. It has the added bonus of being able to be optioned with a drop bed. The Linkwing can raise, lower, widen its decks and can be optioned with an internal hydraulic gooseneck. The linkwing is fully customisable to meet your individual transport needs.

DRAWINGS

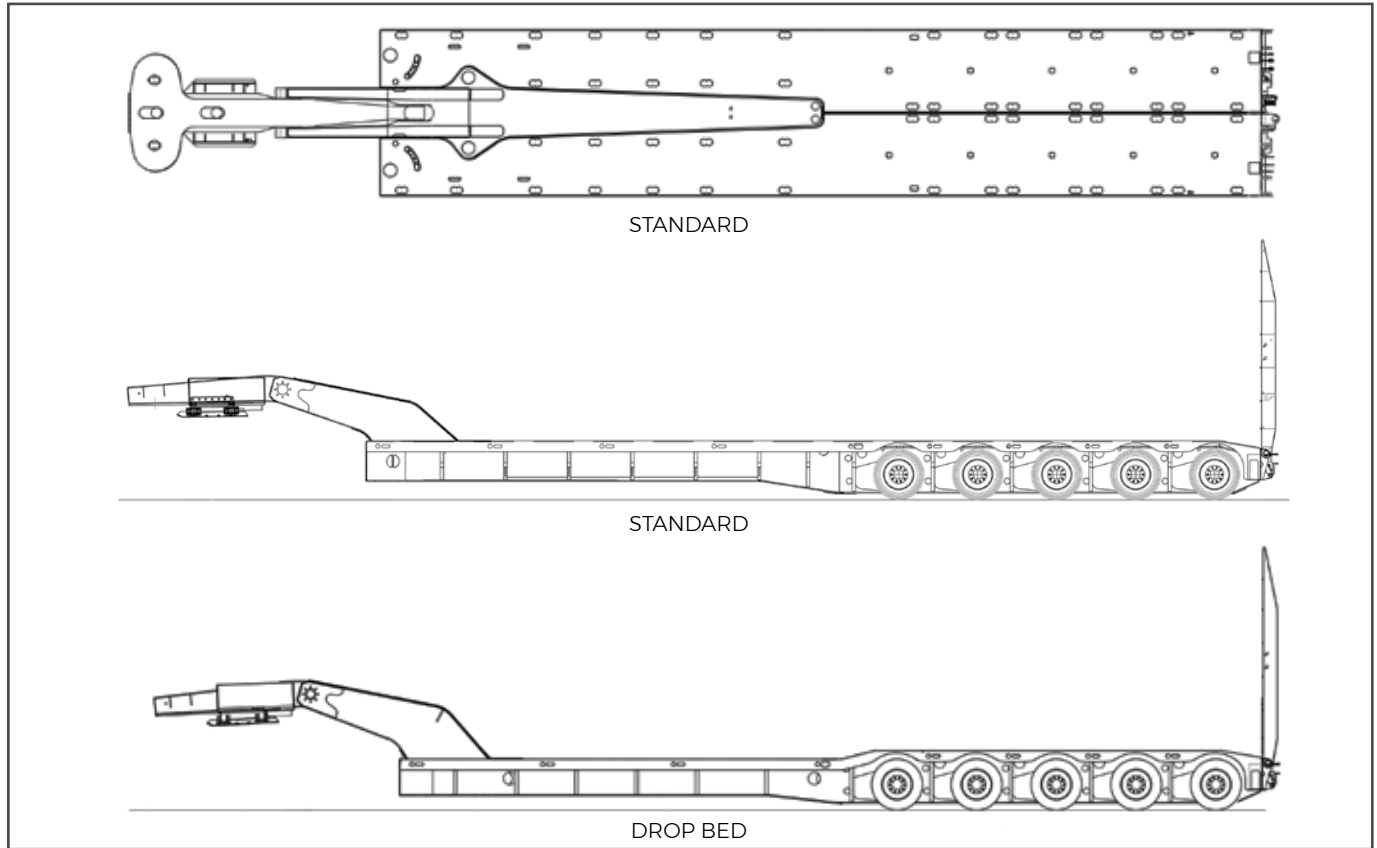

SPECIFICATIONS

STANDARD SPECIFICATIONS (APPROX)

| | |
|--------------------------|---|
| GVM | 110,000kg |
| Deck Length (Overall) | 13807mm |
| Deck Length (Behind G/N) | 12475mm |
| Deck Height | 900mm |
| Widening | 2500mm closed - 4270mm open |
| Axles | MTE 17.5" ten stud 225 PCD |
| Axle Spacing | 1220mm-1220mm-1220mm-1220mm |
| Axle Retraction | Axle Retraction to all axles to facilitate maintenance |
| Suspension | Hydraulic suspension with NEW low maintenance quick change rams |
| Brakes | 12-1/4" x 5-1/2" brakes with outboard drums |
| Greasing | Manual Greasing system 8 points per suspension out to a manual greasing block |
| Tyres | 215 x 17.5" |
| Wheels | Steel wheels |
| Spare Tyre Carriers | 2 |
| Power Source | Truck |

SPECIFICATIONS

| STANDARD SPECIFICATIONS (APPROX) | |
|----------------------------------|--|
| Lighting | LED lights to ADR 4198 with 1 Rotating light in ramp |
| Rub Plate | Two Position Oscillating |
| Rub Plate Height | 1300mm |
| King Pin | 3-1/2" king pin two position |
| Ramps | 3300mm x 1050mm Hydraulic with run-flat ramp stays |
| Toolboxes | 8x Open toolboxes (4x on each side of trailer) |
| Chain Bins | Two chain bins on spine of trailer |
| Link Pins | 150mm diameter front link pins - 100mm diameter rear link pins |
| Signage | "Do not overtake" and "OVERSIZE" |
| Landing Legs | Heavy duty |
| Deck Material | Western Australia Heavy Duty with two x wear straps on neck, 10mm thick deck and 70mm camber |

OPTIONAL EXTRAS

| OPTIONAL EXTRAS (APPROX) | |
|--------------------------|--|
| Wheels | Aluminium Wheels Machined Finish (12.8kg / Wheel) |
| Wheels | Aluminium Wheels Polished Finish (12.8kg / Wheel) |
| Tyres | Specific branded tyres. (Please State) |
| Ramps | Heavy Duty Ramps 1050mm x 3000mm |
| Ramps | Double Fold Ramps 3700mm x 900mm |
| Ramps | Double Fold Ramps 4400mm x 900mm |
| Greasing | Centralised greasing with timer Brakes and suspension |
| Greasing | Centralised greasing with timer Brakes and suspension |
| Remote Control | 12 Function Remote system for operating Gooseneck, Suspension & Widening. |
| Ship Locks | Ship-lock pockets for 20' and 40' containers & 4x double ended ship locks |
| Power Pack | 5.5 HP Diesel power pack, electric start with battery |
| Power Pack | 5.5 HP Petrol power pack, pull start only |
| Power Pack | 5.5 HP Petrol power pack, electric start with battery |
| Gauges | Gauges for load indication |
| Storage | 8x Lockable Toolboxes (4 on each side) |
| Water Tank | Stainless steel water tank and Tap |
| Gooseneck | Hydraulically adjustable gooseneck External |
| Gooseneck | Hydraulically adjustable gooseneck Internal |
| Turntable | Sliding Turntable |
| King Pin | MTE 50mm Drop in Kingpin |
| Odometer | Hub odometer |
| Extendable | 3 Meter Extendable Option (extends in 500mm increments)(13850mm OA deck Length closed) |
| Extendable | 4 Meter Extendable Option (extends in 500mm increments)(14850mm OA deck length closed) |
| Drop Bed | 125mm Drop Bed Option (13190mm OA deck length) |
| Air Hose Reel | Retractable Air hose reel - 15m Hose |

2 ROWS OF 4 DOLLY

A Dolly is a trailer which is coupled to a truck or trailer. Generally, dollies transport trailers by connecting them to trucks or other trailers, forming multi-combination vehicles. The 2R4 Dolly is the standard Dolly and can be coupled to a rows of 4 trailer balancing out your load and allowing for more weight.

DRAWINGS

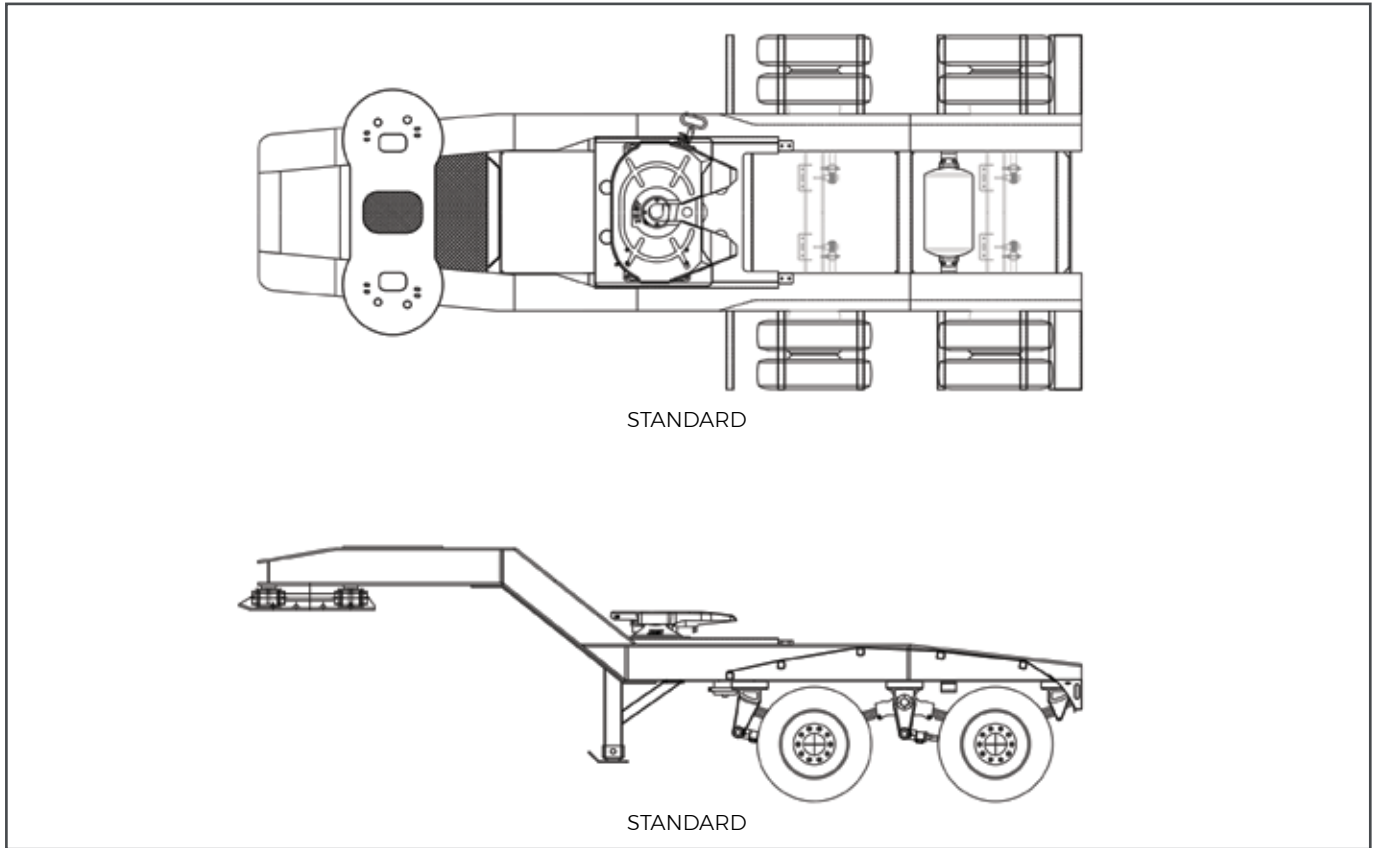

SPECIFICATIONS

| STANDARD SPECIFICATIONS (APPROX) | |
|----------------------------------|---|
| GVM | 36,000kg |
| Width | 2500mm |
| Axles | MTE 17.5" ten stud 225 PCD |
| Axle Spacing | 1250mm |
| Suspension | MTE 8 leaf spring suspension |
| Brakes | 12-1/4" x 5-1/2" brakes with outboard drums |
| Tyres | 235 x 17.5" 18 ply |
| Wheels | Steel wheels |
| Spare Tyre Carriers | 2 |
| Power Source | Truck |
| Lighting | LED lights to ADR 4198 |
| Rub Plate | Oscillating |
| Rub Plate Height | 1300mm |
| 5th Wheel | Semi oscillating 3-1/2" |
| Turntable Height | 1300mm |

SPECIFICATIONS

STANDARD SPECIFICATIONS (APPROX)

| | |
|--------------|-----------------|
| King Pin | 3-1/2" king pin |
| Landing Legs | Standard |

OPTIONAL EXTRAS

OPTIONAL EXTRAS (APPROX)

| | |
|--------------|---|
| Wheels | Aluminium Wheels Machined Finish (12.8kg / Wheel) |
| Wheels | Aluminium Wheels Polished Finish (12.8kg / Wheel) |
| Tyres | Specific branded tyres. (Please State) |
| Tyres | 9.5R 17.5 tyres in Lieu of 235 x 17.5 |
| Axles | 19.5" axles and 265 x 19.5" tyres |
| Suspension | Air Suspension |
| Railing | Sliding rail |
| Power Pack | 5.5HP Petrol Power pack 2000PSI mounted under gooseneck Bottom deck |
| Power Pack | 5.5HP Diesel Power pack 2000PSI mounted under gooseneck Bottom deck |
| Electrical | Air, Electrical lead and Hydraulic Hose |
| Water Tank | Plastic Water Tank fitted |
| Yard Release | Yard release Dual system |

2 ROWS OF 8 WIDENING DOLLY

A Dolly is a trailer which is coupled to a truck or trailer. Generally, dollies transport trailers by connecting them to trucks or other trailers, forming multi-combination vehicles. The 2R8 Dolly is the heavier version of the 2R4 Dolly and can be coupled to a rows of 8 trailer balancing out your load and allowing for more weight.

DRAWINGS

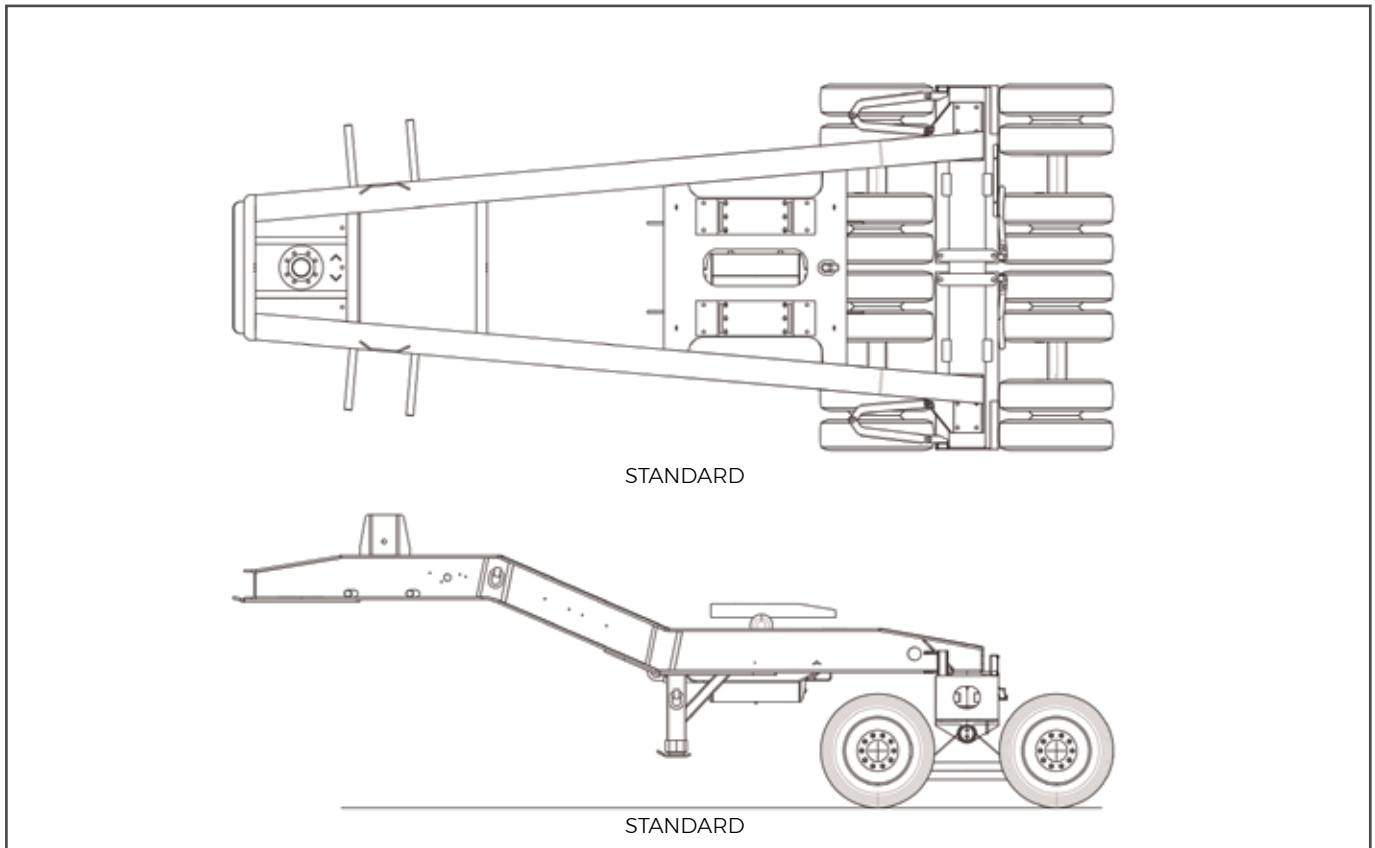

SPECIFICATIONS

| STANDARD SPECIFICATIONS (APPROX) | |
|----------------------------------|--|
| Opening Widths | Closed 2500mm - Open 4260mm |
| Axles | MTE 17.5" Axles ten stud 255mm PCD |
| Axle Spacing | 1250mm |
| Brakes | 12-1/4 x 5-1/2 brakes with outboard drums |
| Yard Release | Button |
| Tyres | 16 x 215 x 17.5 x 16 ply |
| Wheels | Steel wheels |
| Spare Tyre Carriers | 2 |
| Power Source | Truck |
| Lighting | Lights LED type to ADR |
| Rub Plate | Semi Oscillating |
| Rub Plate Height | 52" |
| 5th Wheel | Semi oscillating 3-1/2" 5th Wheel/Turntable on sliding plate |
| King Pin | MTE 3-1/2" drop in King pin two position |
| Landing Legs | Heavy Duty |

OPTIONAL EXTRAS

| OPTIONAL EXTRAS (APPROX) | |
|--------------------------|--|
| Wheels | Aluminium Wheels Machined Finish (12.8kg / Wheel) |
| Wheels | Aluminium Wheels Polished Finish (12.8kg / Wheel) |
| Tyres | Specific branded tyres. (Please State) |
| Railing | Hand rails on both sides of dolly |
| Power Pack | 5.0 HP Diesel power pack, electric start with battery with tyre carriers |
| Power Pack | 5.5 HP Petrol power pack, pull start only with tyre carriers |
| Power Pack | 5.5 HP Petrol power pack, electric start with battery with tyre carriers |
| Electrical | Air, Electrical lead and Hydraulic Hose |
| Water Tank | Plastic Water tank and Tap |
| Water Tank | Stainless Water tank and Tap |
| Rub Plate | Sliding Front Rub Plate |
| King Pin | MTE 50mm Drop in Kingpin |
| Bolster | Bolster on Dolly turntable |
| Bolster | Bolster riser |
| Bolster | Bolster Cradle for supporting beams with Super Tee & Hollow-core jaws |
| Ringfeder | 50mm Ringfeder and mount |

4 ROWS OF 8 WIDENING JINKER

The 4 Rows of 8 Widening Jinker is a trailer designed to transport long logs or other long pieces of material/blocks. A Jinker is generally mounted to a prime mover for transportation. It is often used with a beam set for transporting awkward sized loads

DRAWINGS

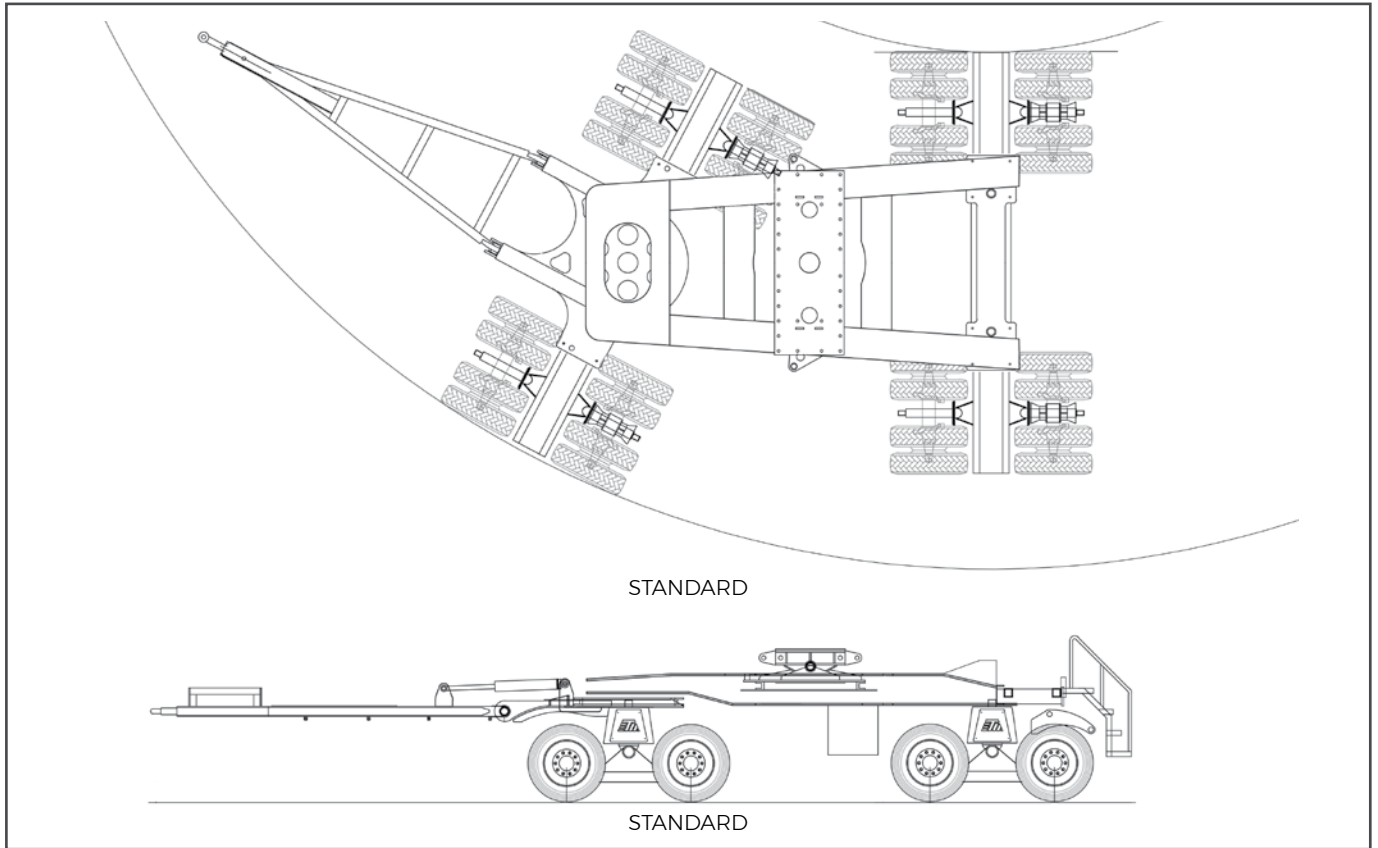

SPECIFICATIONS

| STANDARD SPECIFICATIONS (APPROX) | |
|----------------------------------|--|
| GVM | 60,000kg |
| Widening | Closed 2500mm - Open 4260mm |
| Axles | 15" Axles |
| Axle Spacing | 1200mm - 2400mm - 1200mm |
| Brakes | 12-1/4 x 5- 1/2 brakes with outboard drums |
| Hydraulics | Hydraulic cylinders to steer front Bogie |
| Tyres | 215 x 17.5 x 16 ply |
| Wheels | Steel wheels |
| 5th Wheel | 5th wheel on Double Ball race for 90o steering |
| Ball Race | Ball race on lead Bogie |
| Ringfeder | Ringfeder attachment (No Ringfeder) for empty towing |
| Drawbar | Heavy duty drawbar with landing wheel (70 ton rated) |
| Mud Guards | Plastic guards over wheels |

OPTIONAL EXTRAS

| OPTIONAL EXTRAS (APPROX) | |
|--------------------------|---|
| Wheels | Aluminium Wheels Machined Finish (12.8kg / Wheel) |
| Wheels | Aluminium Wheels Polished Finish (12.8kg / Wheel) |
| Tyres | Specific branded tyres. (Please State) |
| Remote Control | Remote for Steering, Widening, Drawbar, Engine Start/Stop & Warning/Spot Lights |
| Power Pack | 5.0 HP Diesel power pack electric start with battery |
| Electrical | Air, Electrical lead and Hydraulic Hose |
| Steps | Steps to Man Platform on rear with safety rails |
| Bolster | Bolster for Jinker |
| Bolster | Bolster Cradle with Super Tee & Hollow-core jaws |
| Bolster | Widening Man Platform on Bolster with removable safety rails and ladder each side |
| Ringfeder | 50mm Ringfeder |
| Drawbar | Removable Drawbar |
| Drawbar | Beam fixture Frame on Drawbar for towing Jinker |
| Winch | Winch and Cable |

4 ROWS OF 4 JINKER

The 4 Rows of 4 Jinker is a trailer designed to transport long logs or other long pieces of material/blocks. A Jinker is generally mounted to a prime mover for transportation. It is often used with a beam set for transporting awkward sized loads

DRAWINGS

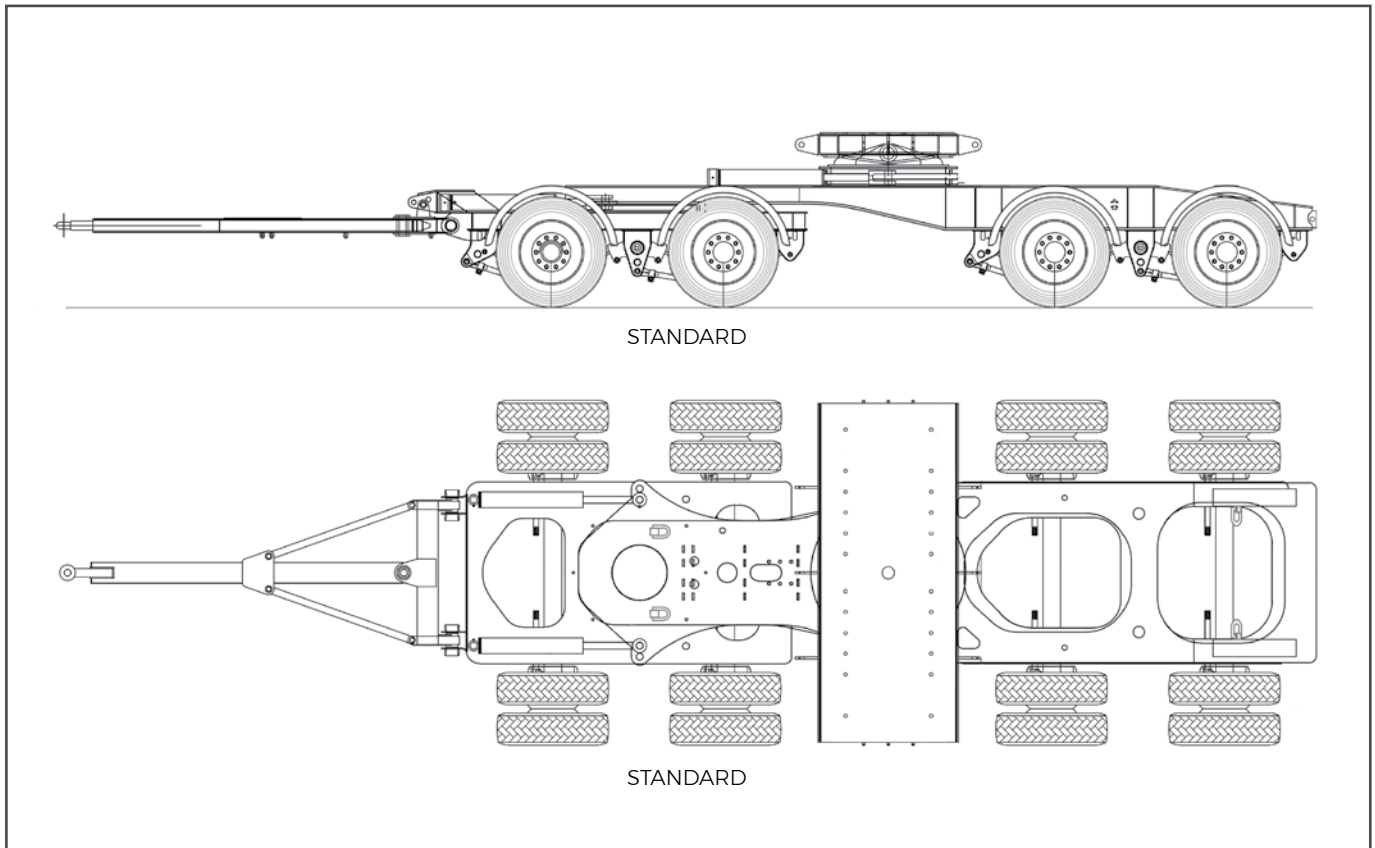

SPECIFICATIONS

| STANDARD SPECIFICATIONS | |
|-------------------------|------------------------------------|
| Width | 2500mm |
| Axles | 17.5" Axles |
| Axle Spacing | 1250mm - 1250mm |
| Suspension | Spring |
| Brakes | Outboard drums & ABS |
| Tyres | 235 x 17.5 |
| Wheels | Steel wheels |
| Lighting | Lights LED type and Multi Volt kit |
| Turntable | Double heavy duty turntable |

OPTIONAL EXTRAS

| OPTIONAL EXTRAS (APPROX) | |
|--------------------------|---|
| Wheels | Aluminium Wheels Machined Finish (12.8kg / Wheel) |
| Wheels | Aluminium Wheels Polished Finish (12.8kg / Wheel) |
| Tyres | Specific branded tyres (Please State) |
| Remote Control | Remote for Steering, Widening, Drawbar, Engine Start/Stop & Warning/Spot Lights |
| Suspension | Air Suspension |
| Power Pack | 9HP Diesel Power pack |
| Ballrace | Second Ball race and Air Lock for 90 degree steering |
| Bolster | Bolster mounting frame |
| Bolster | Bolster for Jinker |
| Bolster | Bolster Cradles - Super Tee & Hollow Core |
| Bolster | Bolster steering system includes 2 cylinders |
| Bolster | Trailer tower section bolster adjustable feet |
| Bolster | Truck Bolster Tower Section adjustable feet 90mm K/P |
| Bolster | Widening Man Platform on Bolster with removable safety rails and ladder each side |

44 METER TRIPLE EXTENDABLE BEAM SET

Designed to be coupled with a Prime Mover or Dolly and Jinker, the 44 Meter Extendable Beam set allows an extremely long load to be carried, which would not fit on a standard transport trailer.

DRAWINGS

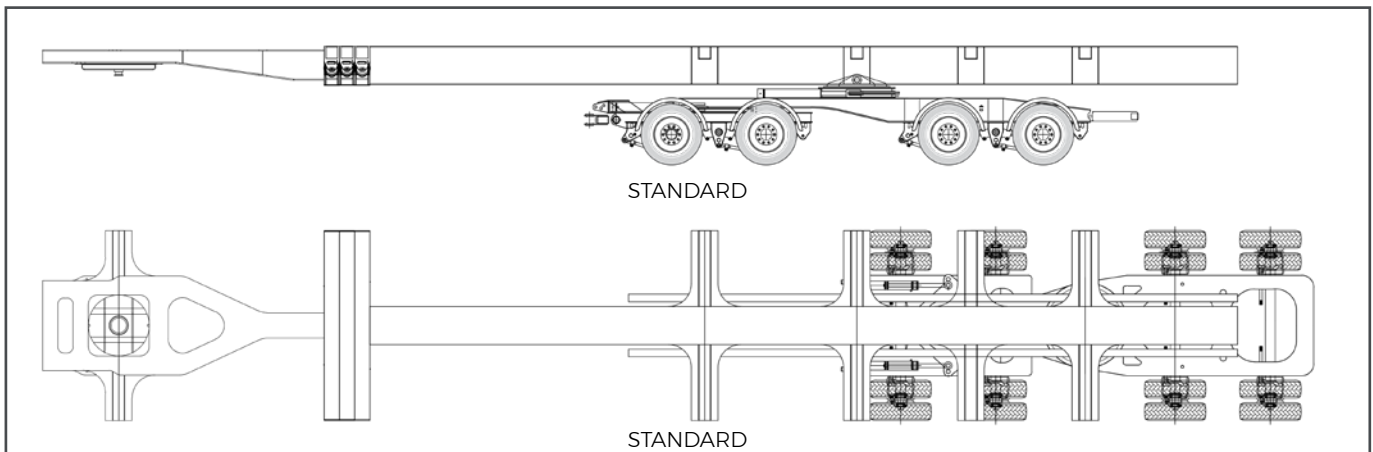

SPECIFICATIONS

| STANDARD SPECIFICATIONS (APPROX) | |
|----------------------------------|--------------------------------------|
| Max Length | 44,000mm |
| Width | 2500mm |
| King Pin | MTE 90mm |
| Positions | 4 Sets of positions for a 4R4 Jinker |
| Tare | 9000kg |
| Capacity | 50,000kg |

50 TONNE EXPANDABLE BEAM SET

Designed to be coupled with a Prime Mover or Dolly and Jinker, the 50 Tonne Expandable Beam set allows large awkward sized loads to be carried, which would not fit on a standard transport trailer.

DRAWINGS

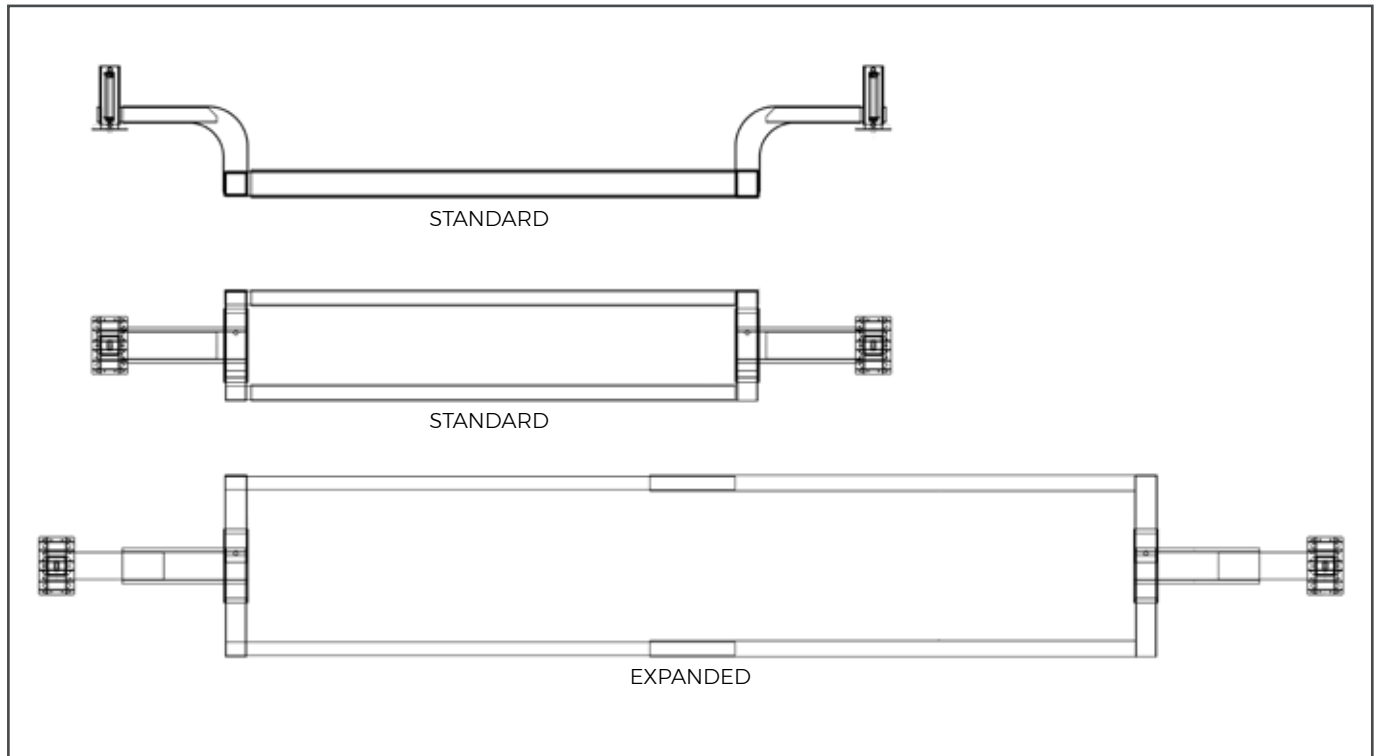

SPECIFICATIONS

STANDARD SPECIFICATIONS (APPROX)

| | |
|--|--|
| Beam Deck height | Lowered: 600mm - Raised: 1400mm |
| Width Closed | 2,500mm |
| Width Open | 4,100mm |
| Length Closed in Well | 10,715mm |
| Length Open in Well | 19,236mm |
| Length K/P to K/P closed in well (Closed ends) | 16,845mm |
| Length K/P to K/P closed in well (Open ends) | 19,208mm |
| Ends extend by increments | 5 of 1700mm |
| Locks and Pins | Air locks and pins at 1000mm centers |
| Gooseneck Height | Gooseneck Height 54", Hydraulic Raising 800mm |
| Capacity | 50,000kg capacity evenly distributed |
| Tare | Tare weight estimated 14,000kg |
| Power Source | Hydraulic power source Dolly or Truck |
| Lights | LED |
| Hydraulic Cylinders | Raising by 2 x 6" hydraulic cylinders |
| King Pin | 2" & 3-1/2" king pin 1 position |
| Beam Material | High strength JFE Hiten 780, tensile 780mpa - 930mpa |

60 TONNE VESSEL BEAM SET

Designed to be coupled with a Prime Mover or Dolly and Jinker, the 60 Tonne Vessel Beam set allow large vessels to be carried, which would not fit on a standard transport trailer.

DRAWINGS

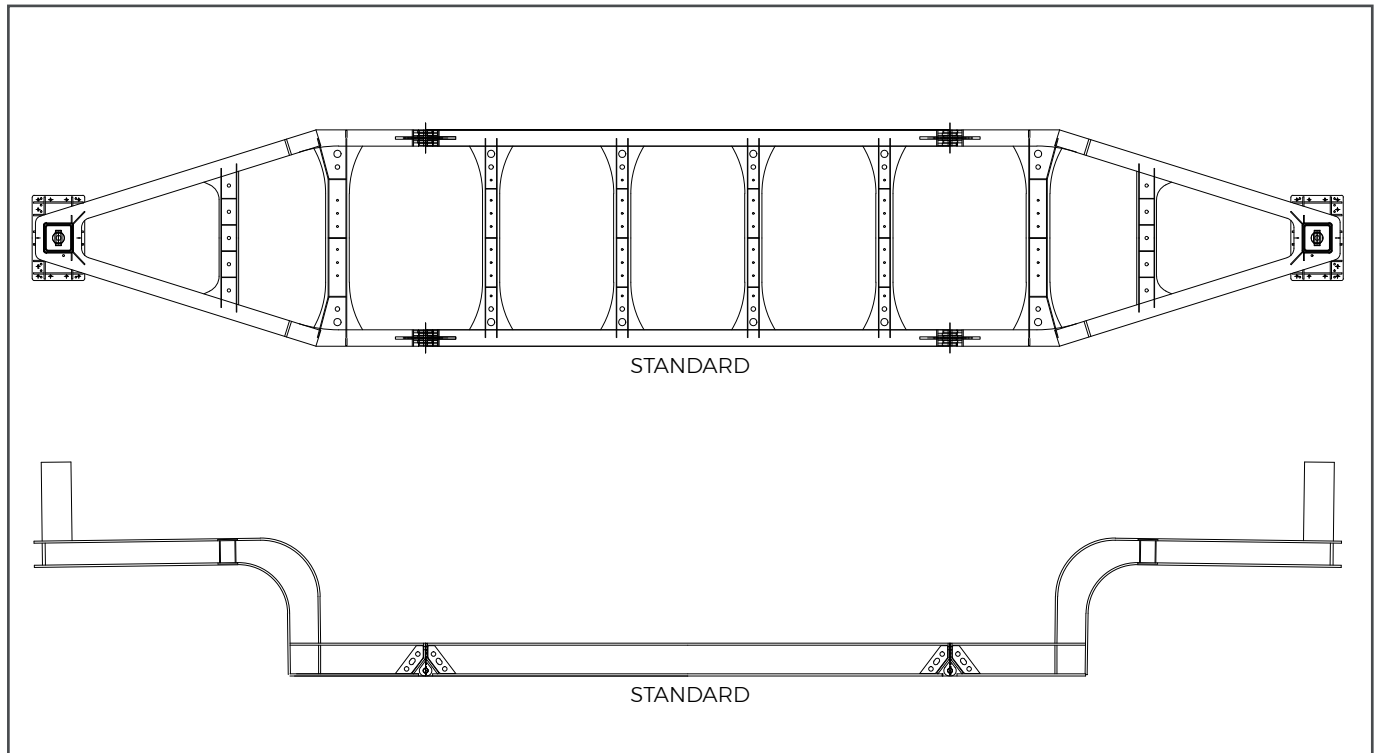

SPECIFICATIONS

| STANDARD SPECIFICATIONS (APPROX) | |
|----------------------------------|--|
| Beam Depth | 500mm |
| Vertical Travel | 800mm |
| Fixed Width | 3300mm |
| Radius for Vessel | 6000mm |
| Gooseneck Clearance | 3700mm |
| Beam Material | High strength JFE Hiten 780, tensile 780mpa -930mpa |
| King Pin | 3-1/2" king pin 1 positions on an Hydraulic skid plate |
| Beam Length | 8000mm 6000mm 5000mm 4000mm 3000mm (26000mm +2x1600mm = 29200mm) |
| Rams | 7" ID Lifting Ram each end, power source Jinker and Dolly |
| Hydraulics | Raising by 1 hydraulic ram each end |
| Lights | LED lights to ADR 4198 sockets on either side |
| Capacity | 60,000kg |
| Tare | 20,000kg |

3 ROWS OF 4 FULL WIDENER

The 3 Rows of 4 Full Widener is a strong and robust trailer designed for the transport of heavy plant and machinery. Top deck or non-top deck options available, comes equipped with hydraulic widening and hydraulic suspension. Various forward lengths and axle spacings are available.

DRAWINGS

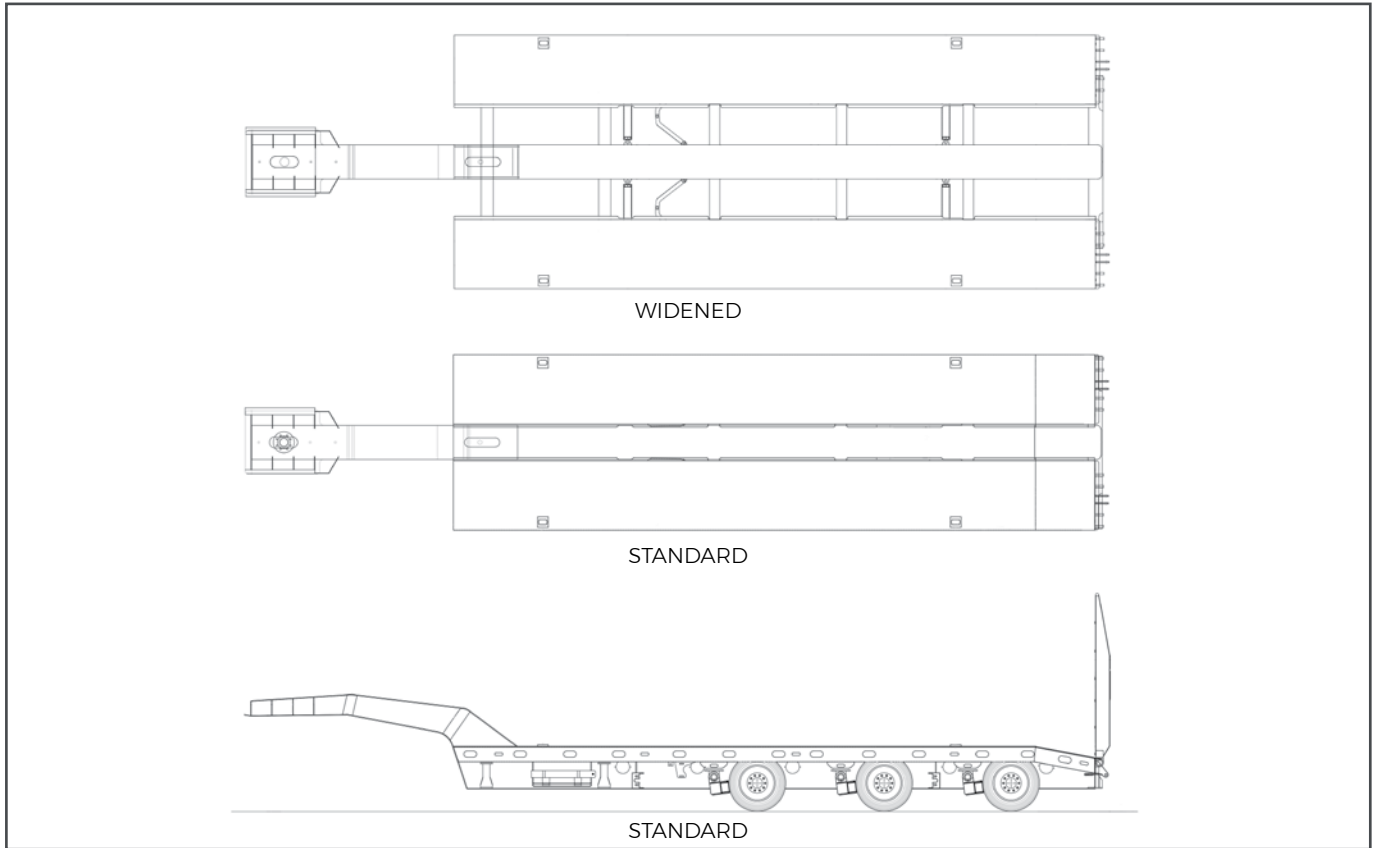

SPECIFICATIONS

| STANDARD SPECIFICATIONS (APPROX) | |
|----------------------------------|--|
| GVM | 45,000kg |
| Deck Height | 880mm |
| Widening | Closed 2500mm - Open 3600mm |
| Forward Length | 9500mm |
| Axles | MTE 17.5" Ten stud axles |
| Axle Spacing | 1830mm |
| Suspension | MTE Hydraulic suspension 10,000kg capacity |
| Brakes | 12-¼ x 7 ½ brakes with outboard drums |
| Brakes | Air mechanical – quick acting Westinghouse circuit to ADR 38 requirements with type 30/30 boosters |
| Tyres | 235 x 17.5 x 16 ply |
| Wheels | Steel wheels |
| Lighting | LED Multi Volt |
| Electrical | 6mm molded wiring loom with seven-pin base at front electrical loom to ADR 38 regulations |
| Controls | Hydraulic controls at rear between ramps |
| Turntable Height | 1320mm |

SPECIFICATIONS

| STANDARD SPECIFICATIONS (APPROX) | |
|----------------------------------|---|
| Ramps | 900mm x 2700mm Hydraulic |
| Signage | Clip on Hazard Panels |
| Landing Legs | Landing Legs with east / west pins |
| Deck Material | High Tensile steel construction 8mm deck with 12mm neck flanges |

OPTIONAL EXTRAS

| OPTIONAL EXTRAS (APPROX) | |
|--------------------------|---|
| Wheels | Aluminium Wheels Machined Finish (12.8kg / Wheel) |
| Wheels | Aluminium Wheels Polished Finish (12.8kg / Wheel) |
| Wheels | Specific branded tyres. (Please State) |
| Ramps | Double Fold Ramps 3700mm x 900mm |
| Ramps | Double Fold Ramps 4400mm x 900mm |
| Greasing | Centralised greasing Brakes and suspension |
| Greasing | Manual greasing out to a Block |
| Ship Locks | Twist locks to suit 1 20' container |
| Axles | 19.5" axles |
| Power Pack | 5.5 HP Honda power pack |
| Power Pack | 5.5 HP Diesel power pack |
| Electrical | Air, Electrical lead and Hydraulic Hose |
| Storage | Tool box fitted |
| Water Tank | Stainless steel water tank and tap |
| Water Tank | Plastic water tank |
| Rub Plate | Semi Oscillating Rub plate |
| Rub Plate | Sliding Rub plate |
| King Pin | MTE 50mm Drop in King pin |
| Top Deck | Top Deck (Non folding type) |
| Deck | Western Australia Specs 8mm deck |
| Drop Bed | 125mm Drop Bed Option |

4 ROWS OF 4 FULL WIDENER

The 4 Rows of 4 Full Widener is a strong and robust trailer designed for the transport of heavy plant and machinery. Drop bed options available, comes equipped with hydraulic widening and hydraulic suspension. Various forward lengths and axle spacings are available.

DRAWINGS

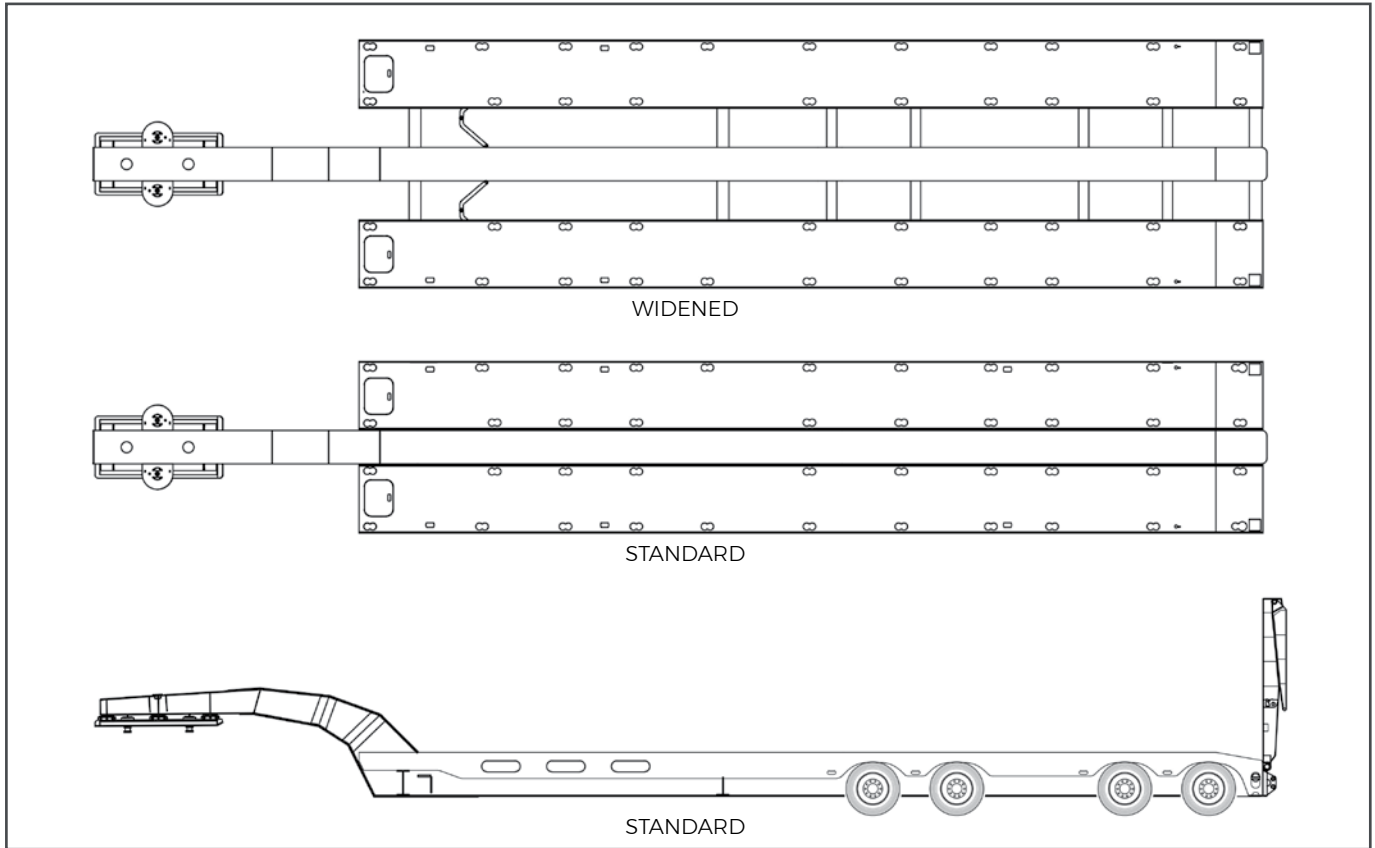

SPECIFICATIONS

| STANDARD SPECIFICATIONS (APPROX) | |
|----------------------------------|---|
| GVM | 65,000kg |
| Deck Length (Overall) | 13126mm |
| Deck Length (Behind G/N) | 12320mm |
| Deck Height | 950mm |
| Widening | 2500mm closed - 3600mm open |
| Forward Length | 13202mm |
| Axles | 17.5" Ten stud |
| Axle Spacing | 1220mm - 2400mm - 1220mm |
| Suspension | Hydraulic Suspension |
| Brakes | 12-1/4 x 7-1/2" brakes with outboard drums |
| Brakes | ABS Full air brakes to ADR |
| Greasing | Greasing out to centralized blocks on each suspension |
| Tyres | 235 x 17.5 |
| Wheels | Steel wheels |
| Spare Tyre Carriers | 2 |

SPECIFICATIONS

| STANDARD SPECIFICATIONS (APPROX) | |
|----------------------------------|--|
| Rub Plate | Oscillating |
| King Pin | 2 Position |
| Ramps | 2700mm x 900mm |
| Signage | "Do Not Overtake Turning Vehicle" and "OVERSIZE" |
| Deck Material | Steel 80 grade high tensile Deck plate 6mm |

OPTIONAL EXTRAS

| OPTIONAL EXTRAS (APPROX) | |
|--------------------------|---|
| Wheels | Aluminium Wheels Machined Finish (12.8kg / Wheel) |
| Wheels | Aluminium Wheels Polished Finish (12.8kg / Wheel) |
| Tyres | Specific branded tyres. (Please State) |
| Tyres | 9.5R17.5 tyres in Lieu of 235 x 17.5 |
| Ramps | Double Fold Ramps (3700mm x 900mm) |
| Greasing | Central auto greasing with timer |
| Ship Locks | Twist locks to suit 1 x 40' & 1 x 20' container |
| Axles | 19.5" Axles and 265 x 19.5" tyres |
| Axles | Air operated axle retraction 1st and last axle |
| Yard Release | Yard release Dual system |
| Power Pack | 5.5HP Petrol Power pack 2000PSI mounted under gooseneck Bottom deck |
| Power Pack | 5.5HP Diesel Power pack 2000PSI mounted under gooseneck Bottom deck |
| Electrical | Air, Electrical lead and Hydraulic Hose |
| Storage | Toolbox fitted |
| Water Tank | Plastic Water Tank fitted |
| Rub Plate | Sliding rub plate |
| Deck | Western Australia Specs 8mm deck |
| Drop Bed | Drop Bed 125mm |

4 ROWS OF 4 FULL WIDENER (STEERING)

The 4 Rows of 4 Full Widener is a strong and robust trailer designed for the transport of heavy plant and machinery. This steering model allows for greater maneuverability over both the standard model and castor steering model. Drop bed option available, comes equipped with hydraulic widening and hydraulic suspension. Various forward lengths and axle spacings are available.

DRAWINGS

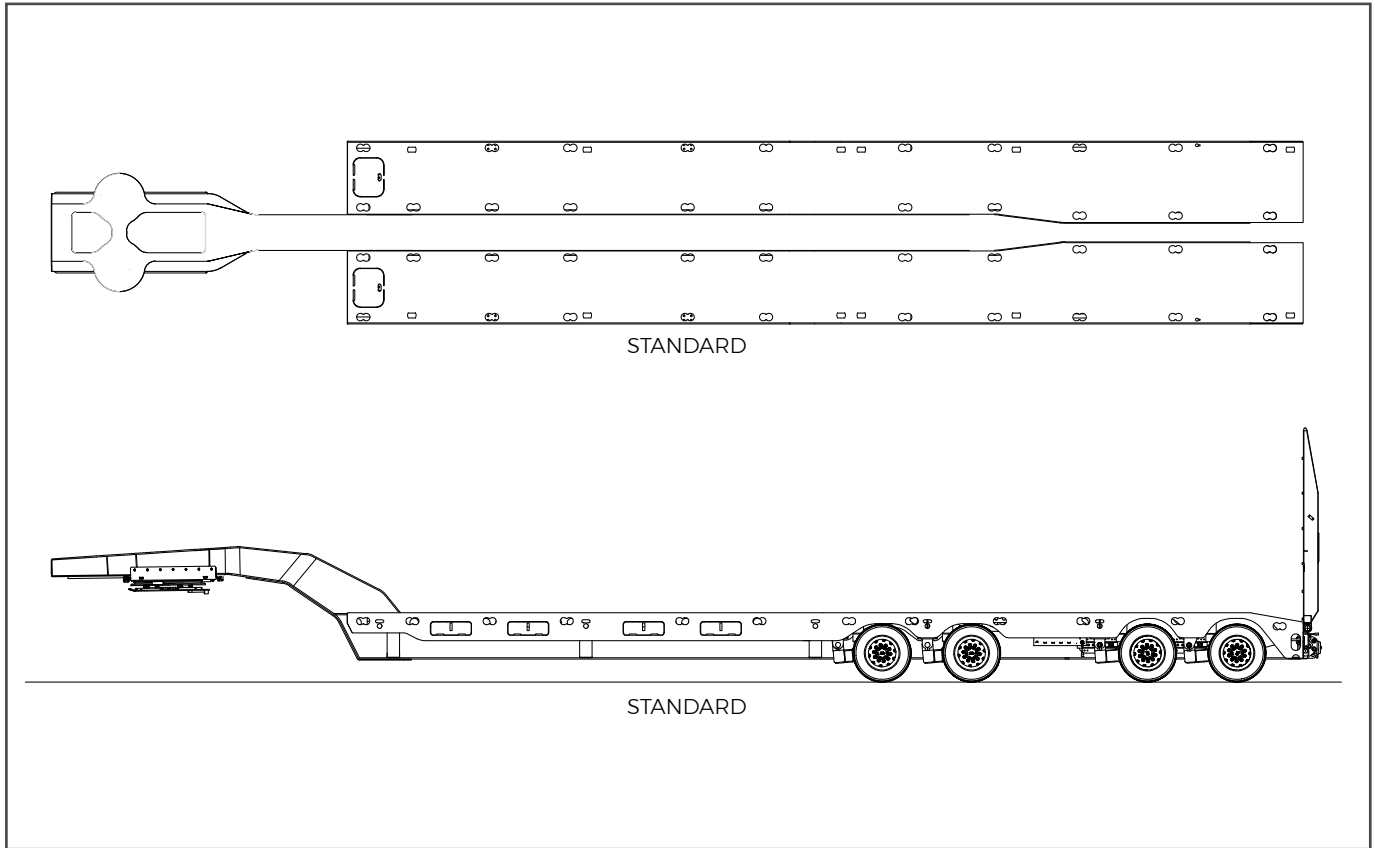

SPECIFICATIONS

| STANDARD SPECIFICATIONS (APPROX) | |
|----------------------------------|---|
| GVM | 55,000kg |
| Deck Length (Overall) | 1 = 12200mm or 2 = 11672mm |
| Deck Height | 950mm |
| Widening | Closed 2500mm - Open 3600mm |
| Forward Length | 1 = 11767mm or 2 = 12367mm |
| Axles | 2 of Fixed 15" ten stud axles |
| Axles | 2 of Steering 15" ten stud axles |
| Axle Spacing | 1240mm 2400mm 1240mm |
| Suspension | Hydraulic |
| Brakes | 12 ¼" x 7 ½" brakes with outboard drums |
| Brakes | Full air brakes to ADR |
| Greasing | Grease nipples to suspension pins |
| Tyres | 235 x 17.5 |
| Wheels | Steel wheels |
| Spare Tyre Carriers | 2 |

SPECIFICATIONS

| STANDARD SPECIFICATIONS (APPROX) | |
|----------------------------------|--|
| Rub Plate | Sliding |
| Ramps | 2800mm x 850mm |
| Signage | "Do Not Overtake Turning Vehicle" and "OVERSIZE" |
| Deck Material | Steel 80 grade high tensile Deck plate 6mm |

OPTIONAL EXTRAS

| OPTIONAL EXTRAS (APPROX) | |
|--------------------------|---|
| Wheels | Aluminium Wheels Machined Finish (12.8kg / Wheel) |
| Wheels | Aluminium Wheels Polished Finish (12.8kg / Wheel) |
| Tyres | Specific branded tyres. (Please State) |
| Tyres | Spare tyre and Steel wheel 235 x 17.5 |
| Ramps | Double Fold Ramps 3700mm x 900mm |
| Ramps | Double Fold Ramps 4400mm x 900mm |
| Greasing | Central greasing with timer |
| Ship Locks | Twist locks to suit 1 x 40' & 1 x 20' container |
| Yard Release | Yard release Dual system |
| Power Pack | 5.5HP Petrol Power pack 2000PSI mounted under gooseneck Bottom deck |
| Power Pack | 5.5HP Diesel Power pack 2000PSI mounted under gooseneck Bottom deck |
| Electrical | Air, Electrical lead and Hydraulic Hose |
| Storage | Toolbox |
| Water Tank | Plastic Water Tank fitted |

4 ROWS OF 4 DECK WIDENER

The 4 Rows of 4 Deck Widener is a strong and robust trailer designed for the transport of heavy plant and machinery. Deck wideners are used mainly where wide machines need to be transported into areas where access is difficult and roads are narrow. The wheels stay at 2.5m wide but decks can widen up to 3.5m to suit the width of the load.

DRAWINGS

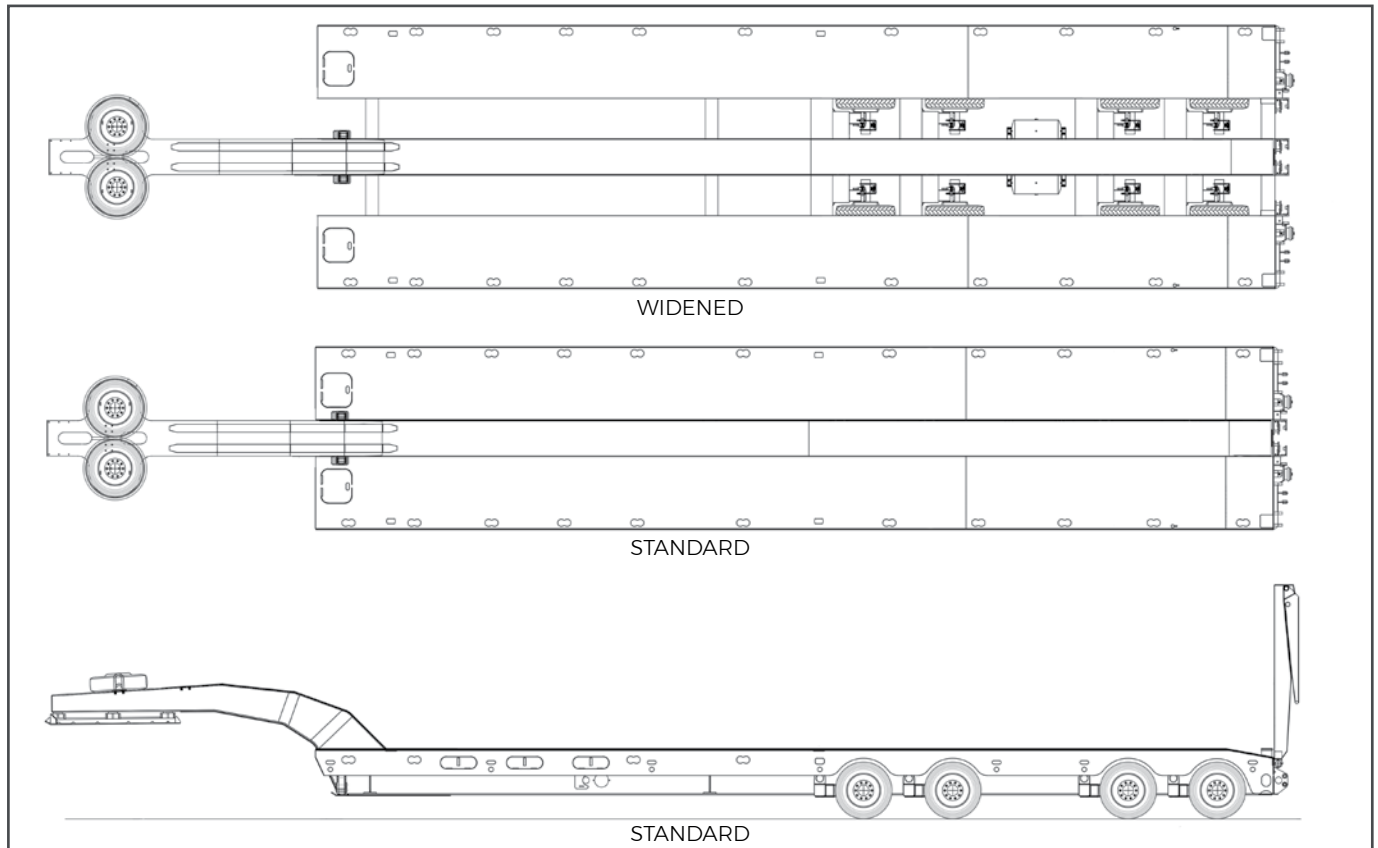

SPECIFICATIONS

STANDARD SPECIFICATIONS (APPROX)

| | |
|---------------------|--|
| GVM | 60,000kg |
| Deck Height | 950mm |
| Widening | Closed 2500mm - Open 3600mm |
| Axles | 15" ten stud axles |
| Axle Spacing | 1220mm - 2400mm - 1220mm |
| Suspension | Hydraulic |
| Brakes | 12 1/4 x 7 1/2" brakes with outboard drums |
| Brakes | Full air brakes to ADR |
| Greasing | Grease nipples to suspension pins |
| Tyres | 215 x 17.5 |
| Wheels | Steel wheels |
| Spare Tyre Carriers | 2 |
| Lighting | LED |
| Rub Plate | Oscillating |
| King Pin | 2 Position |

SPECIFICATIONS

| STANDARD SPECIFICATIONS (APPROX) | |
|----------------------------------|--|
| Ramps | 2800mm x 850mm |
| Signage | "Do Not Overtake Turning Vehicle" and "OVERSIZE" |
| Deck Material | Steel 80 grade high tensile Deck plate 6mm |

OPTIONAL EXTRAS

| OPTIONAL EXTRAS (APPROX) | |
|--------------------------|---|
| Wheels | Aluminium Wheels Machined Finish (12.8kg / Wheel) |
| Wheels | Aluminium Wheels Polished Finish (12.8kg / Wheel) |
| Tyres | Specific branded tyres. (Please State) |
| Tyres | 19.5R17.5 tyres (in Lieu of 215 x 17.5) |
| Ramps | Double Fold Ramps |
| Greasing | Central greasing with timer |
| Ship Locks | Twist locks to suit 1 x 40' 1 x20' container |
| Axles | 19.5" axles and 265x 19.5 tyres |
| Axles | Air operated axle retraction 1st and last axle |
| Yard Release | Yard release Dual system |
| Power Pack | 5.5HP Petrol Power pack 2000PSI mounted under gooseneck Bottom deck |
| Power Pack | 5.5HP Diesel Power pack 2000PSI mounted under gooseneck Bottom deck |
| Electrical | Air, Electrical lead and Hydraulic Hose |
| Storage | Toolbox |
| Water Tank | Plastic Water Tank |
| Turntable | Sliding turntable |
| Deck | Western Australia Specs 8mm deck |
| Drop Bed | Drop Bed 125mm |

4 ROWS OF 4 DECK WIDENER

The 4 Rows of 4 Deck Widener is a strong and robust trailer designed for the transport of heavy plant and machinery. Deck wideners are used mainly where wide machines need to be transported into areas where access is difficult and roads are narrow. The wheels stay at 2.5m wide but decks can widen up to 3.5m to suit the width of the load.

DRAWINGS

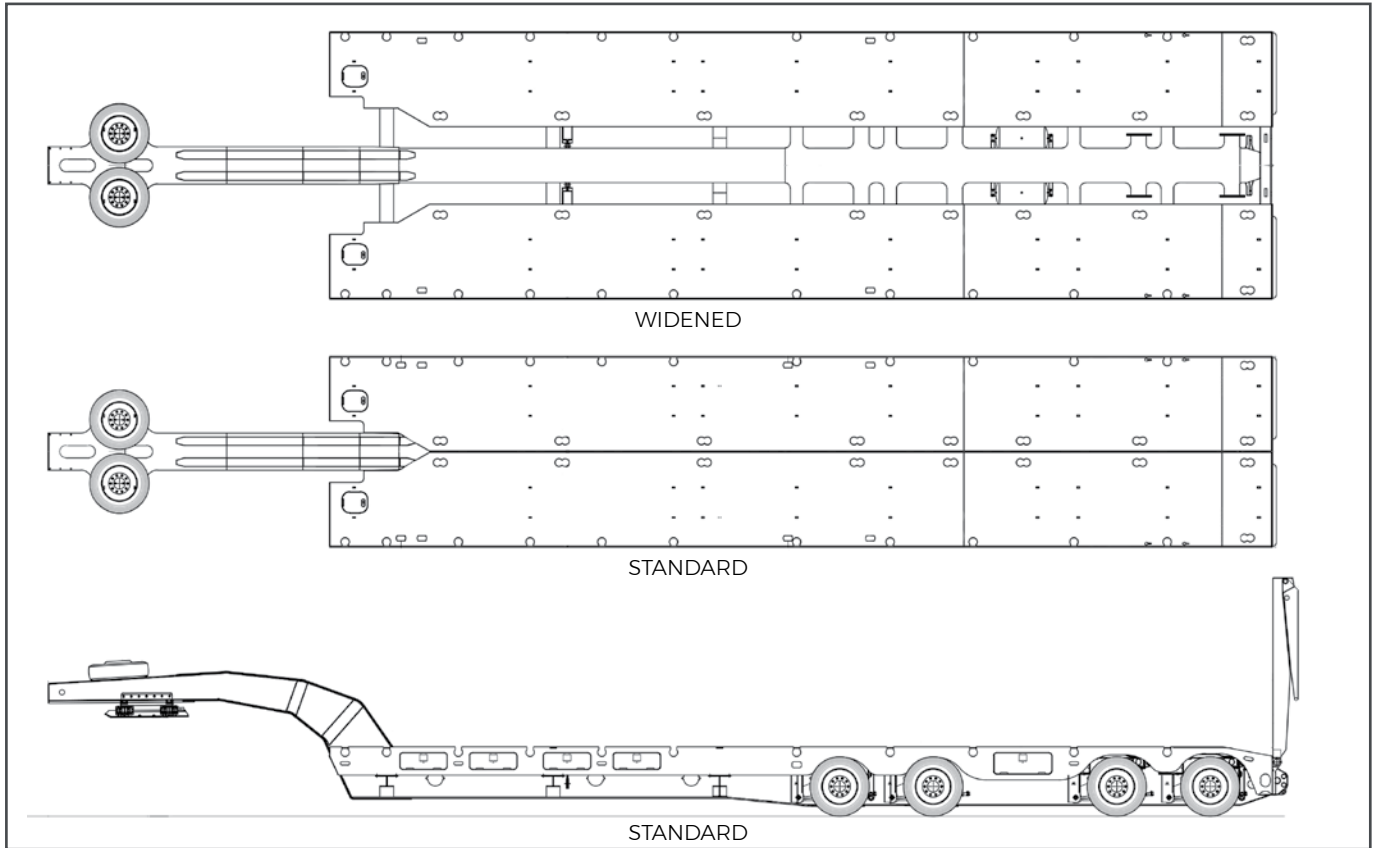

SPECIFICATIONS

| STANDARD SPECIFICATIONS (APPROX) | |
|----------------------------------|---|
| GVM | 60,000kg |
| Deck Height | 950mm |
| Deck Widths | 2 x 1250mm |
| Widening | Closed 2500mm - Open 3500mm |
| Axles | 19.5" eight stud axles |
| Axle Spacing | 1220mm - 2400mm - 1220mm |
| Suspension | Hendrickson air suspension |
| Brakes | 15" x 8.625" brakes with outboard drums |
| Brakes | Full air brakes to ADR With ABS |
| Tyres | 265 x 19.5 |
| Wheels | Steel wheels |
| Spare Tyre Carriers | 2 |
| Lighting | LED |
| Rub Plate | 2 Position |
| Ramps | 2700mm x 900mm |

SPECIFICATIONS

| STANDARD SPECIFICATIONS (APPROX) | |
|----------------------------------|--|
| Signage | "Do Not Overtake Turning Vehicle" and "OVERSIZE" |
| Deck Material | Steel 80 grade high tensile Deck plate 6mm |
| Ship Locks | Twist locks - 1 x 20' container |

OPTIONAL EXTRAS

| OPTIONAL EXTRAS (APPROX) | |
|--------------------------|---|
| Wheels | Aluminium Wheels Machined Finish (12.8kg / Wheel) |
| Wheels | Aluminium Wheels Polished Finish (12.8kg / Wheel) |
| Tyres | Specific branded tyres. (Please State) |
| Ramps | Double Fold Ramps |
| Axles | Axle retraction per axle |
| Axles | 2 x Steering Axles 2 x Fixed Axles (Stefan) |
| Axles | 2 x Steering Axles 2 x Fixed Axles (BPW) |
| Suspension | MTE Hydraulic Suspension |
| Yard Release | Yard release Dual system |
| Power Pack | 5.5HP petrol Power pack 2000PSI mounted |
| Power Pack | 5.5HP Diesel Power pack 2000PSI mounted |
| Electrical | Air, Electrical lead and Hydraulic Hose |
| Storage | Toolbox |
| Water Tank | Plastic Water Tank |
| Winch | 20,000lb Winch on gooseneck |
| Deck | 8mm deck instead of 6mm decks Adds approx. 500kg |

3 ROWS OF 4 EXTENDING AND DECK WIDENER

The 3 Rows of 4 Extending and Deck Widener is a strong and robust trailer designed for the transport of heavy plant and machinery. Extending and Deck wideners are used mainly where wide machines need to be transported into areas where access is difficult. The wheels stay at 2.5m wide but decks can widen up to 3.5m and extend to a custom length to suit the size of the load.

DRAWINGS

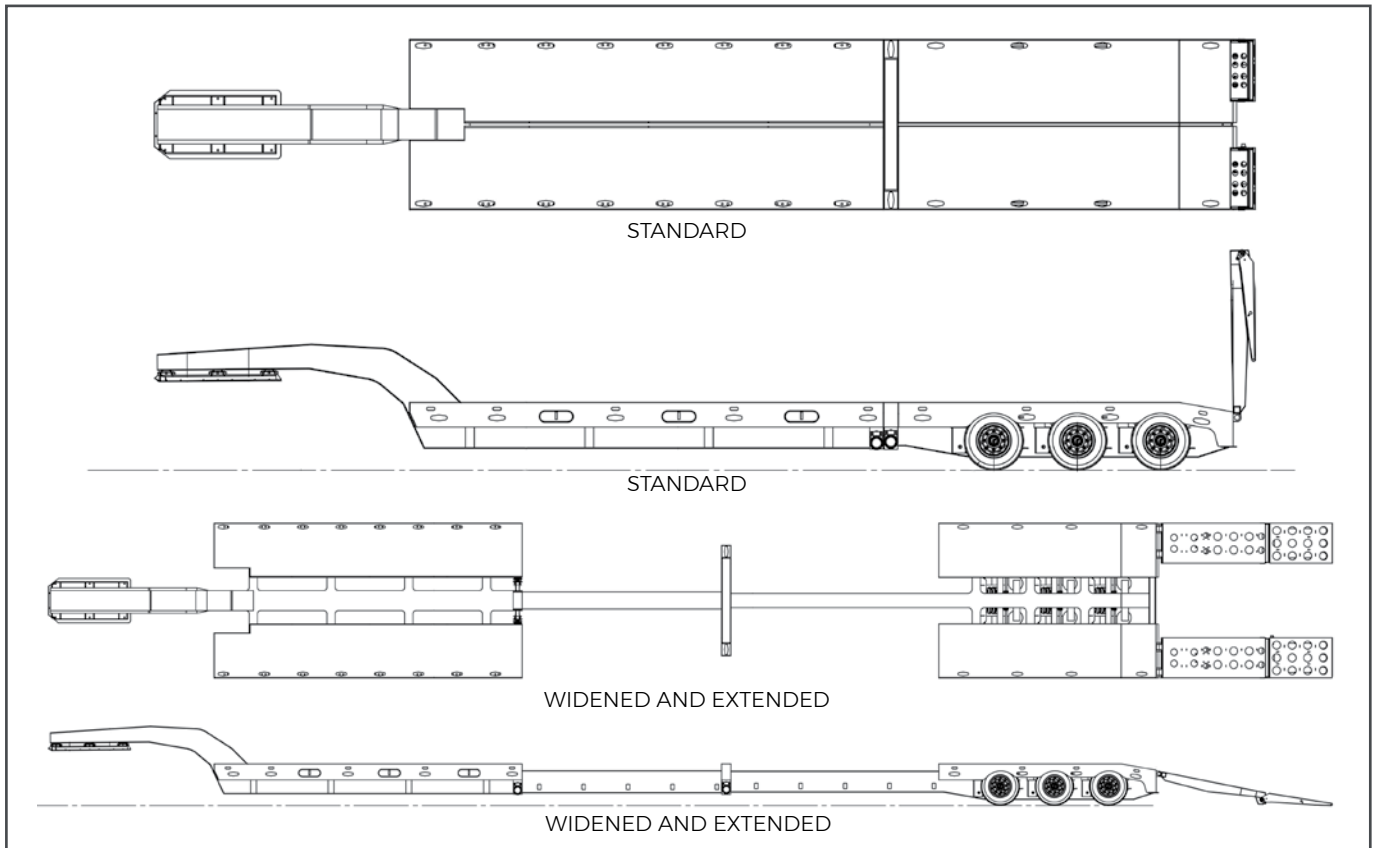

SPECIFICATIONS

| STANDARD SPECIFICATIONS (APPROX) | |
|----------------------------------|---|
| Widening | Closed 2500mm - Open 3500mm |
| Axles | MTE 17.5" |
| Axle Spacing | 1250mm - 1250mm |
| Suspension | Hendrickson Airbag Suspension |
| Brakes | Outboard Drum Brakes |
| Brakes | Full air brakes to ADR, Australian compliance plate |
| Greasing | Manual |
| Tyres | 215 x 75 x 17.5 |
| Wheels | Steel wheels |
| Spare Tyre Carriers | 2 |
| Lighting | LED |
| Controls | Control mounted on the driver's side |
| Rub Plate | Fixed Position |
| King Pin | 2" or 3 1/2" King pin |
| Ramps | Eco Tail sliding ramp |

SPECIFICATIONS

| STANDARD SPECIFICATIONS (APPROX) | |
|----------------------------------|---|
| Toolboxes | 2 XL toolboxes fitted in coaming - (totals to 8 small due to container locks) |
| Signage | "Do Not Overtake turning Vehicle" and "OVERSIZE" |
| Landing Legs | Wind down support legs |
| Deck Material | Steel 80 Grade 6mm High Tensile plate floor |
| Top Deck | Flip over style gooseneck deck |
| Pontoon | 1250mm pontoon width bottom decks |

OPTIONAL EXTRAS

| OPTIONAL EXTRAS (APPROX) | |
|--------------------------|---|
| Wheels | Aluminium Wheels Machined Finish (12.8kg / Wheel) |
| Wheels | Aluminium Wheels Polished Finish (12.8kg / Wheel) |
| Tyres | Specific branded tyres. (Please State) |
| Ramps | Bi-fold ramps - 2700mm & 1200 x 900mm. Quick release coupling |
| Ship Locks | 3 way container locks |
| Axles | MTE 19.5" axles and 265 tyres |
| Suspension | Hydraulic suspension |
| Power Pack | 5 HP Petrol Power Pack |
| Water Tank | Plastic Water Tank |
| Gooseneck | 2 position dolly gooseneck |
| Top Deck | Fold Up top Deck |
| Extendable | 1st Extension (1 x 3,800mm) plus extra widening cylinders |
| Extendable | 2nd Extension (1 x 3,700mm) |

4 ROWS OF 4 EXTENDING AND DECK WIDENER

The 4 Rows of 4 Extending and Deck Widener is a strong and robust trailer designed for the transport of heavy plant and machinery. Extending and Deck wideners are used mainly where wide machines need to be transported into areas where access is difficult. The wheels stay at 2.5m wide but decks can widen up to 3.5m and extend to a custom length to suit the size of the load.

DRAWINGS

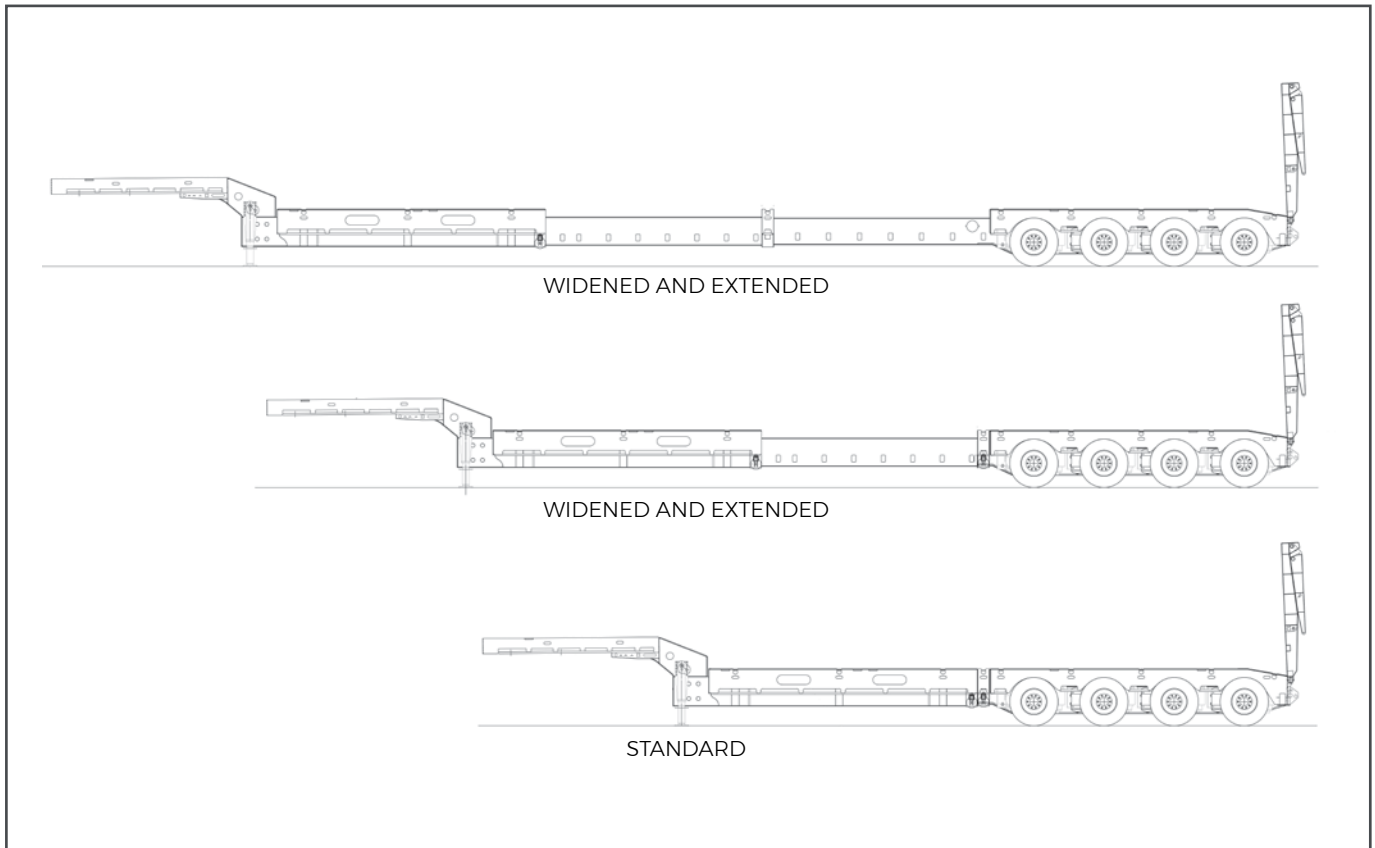

SPECIFICATIONS

STANDARD SPECIFICATIONS (APPROX)

| | |
|---------------------|---|
| Widening | Closed 2500mm - Open 3500mm |
| Axles | 19.5" Disk Brake BPW Axles |
| Axle Spacing | 1250mm - 1250mm - 1250mm |
| Axle Retraction | Axle lift on 1st Axle and 4th Axle (2 different lengths of hooks) |
| Suspension | BPW Airbag Suspension |
| Brakes | Disk Brake |
| Brakes | Full air brakes to ADR. With ABS Australian compliance plate |
| Greasing | Manual greasing |
| Tyres | 265 x 75 x 19.5 |
| Wheels | Steel wheels |
| Spare Tyre Carriers | 2 |
| Lighting | LED |
| Controls | Control mounted on the driver's side |
| Rub Plate | Two position |
| King Pin | 2" or 3 1/2" King pin |

SPECIFICATIONS

| STANDARD SPECIFICATIONS (APPROX) | |
|----------------------------------|---|
| Ramps | Bi-fold ramps – 2700mm & 1200 x 900mm. Quick release coupling |
| Toolboxes | 4 XL toolboxes fitted in coaming – (totals to 8 small due to container locks) |
| Signage | “Do Not Overtake turning Vehicle” and “OVERSIZE” |
| Landing Legs | Wind down support legs |
| Deck Material | Steel 80 Grade 6mm High Tensile plate floor. |
| Top Deck | Fold Up top Deck |
| Pontoon | 1250mm pontoon width decks |

OPTIONAL EXTRAS

| OPTIONAL EXTRAS (APPROX) | |
|--------------------------|---|
| Wheels | Aluminium Wheels Machined Finish (12.8kg / Wheel) |
| Wheels | Aluminium Wheels Polished Finish (12.8kg / Wheel) |
| Tyres | Specific branded tyres. (Please State) |
| Ship Locks | 3 way container locks |
| Suspension | Hendrickson Air Suspension |
| Brakes | MTE 19.5 Drum Brakes |
| Power Pack | 5 HP Petrol Power Pack |
| Water Tank | Plastic Water Tank |
| Extendable | 1st Extension (1 x 3,800mm) plus extra widening cylinders |
| Extendable | 2nd Extension (1 x 3,700mm) |

4 ROWS OF 4 SWINGWIDE

The 4 Rows of 4 Swingwide is a strong and robust trailer designed for the transport of awkward size loads and machinery. Due to its large GVM, it is able to securely and safely load your heavy duty gear.

DRAWINGS

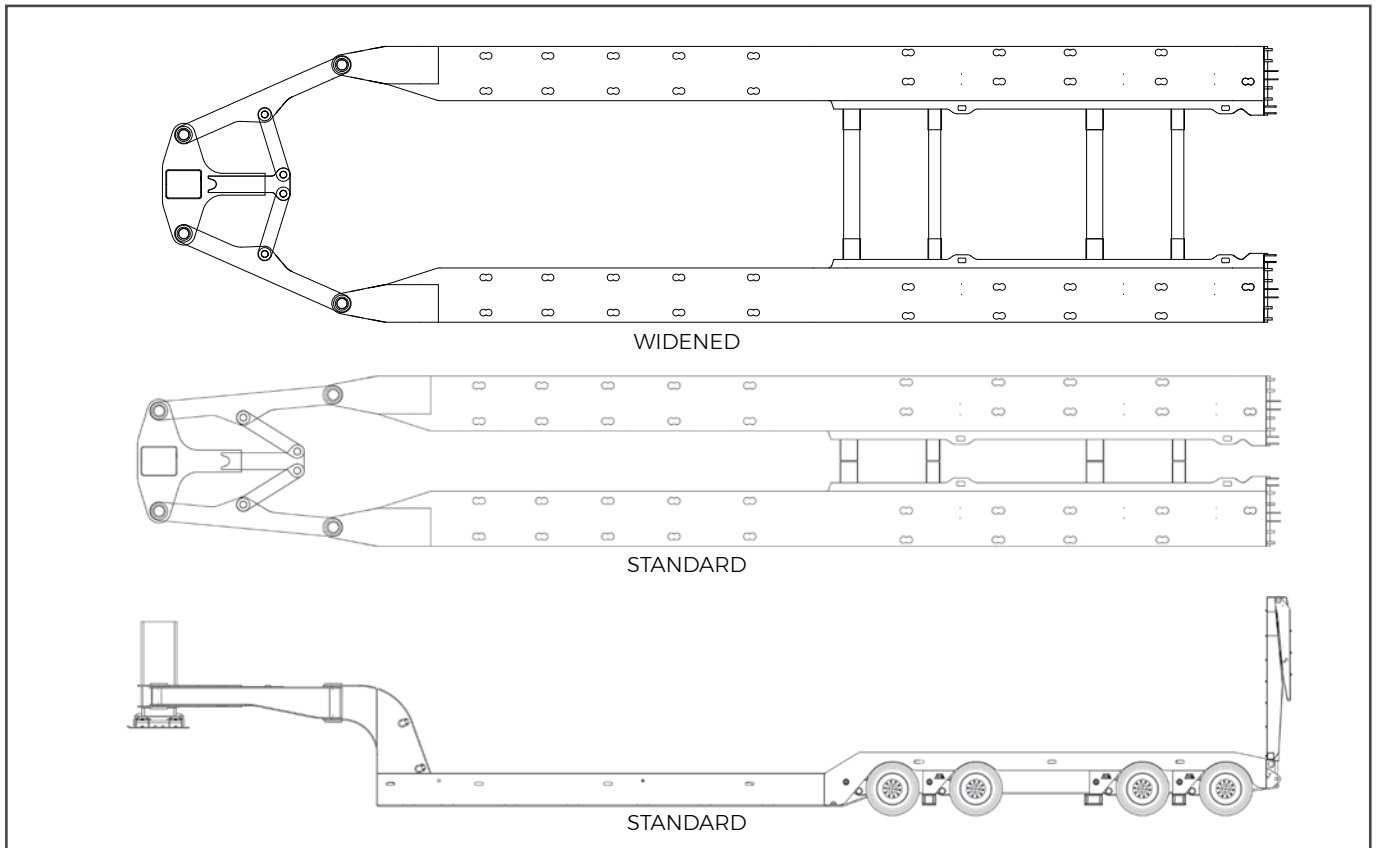

SPECIFICATIONS

STANDARD SPECIFICATIONS (APPROX)

| | |
|---------------------|---|
| GVM | 55,000kg |
| Deck Height | 950mm |
| Widening | Width 2500mm closed Width 4000mm open |
| Axles | 15" Ten stud |
| Axle Spacing | 1220mm - 2400mm - 1220mm |
| Suspension | Hydraulic Suspension |
| Brakes | 12 ¼" x 7 ½" brakes with outboard drums |
| Brakes | Full air brakes to ADR |
| Greasing | Grease nipples to suspension pins |
| Tyres | 215 x 17.5 |
| Wheels | Steel Wheels |
| Spare Tyre Carriers | 2 Spare tyre carriers |
| Lighting | LED |
| Rub Plate | Hydraulic raising rub plate |
| Ramps | 2800mm x 850mm |

SPECIFICATIONS

| STANDARD SPECIFICATIONS (APPROX) | |
|----------------------------------|---|
| Signage | Signs "Do Not Overtake Turning Vehicle" and "OVERSIZE" will be fitted |
| Deck Material | Steel 80 grade high tensile Deck plate 6mm |
| Drop Bed | 300mm Drop Bed |

OPTIONAL EXTRAS

| OPTIONAL EXTRAS (APPROX) | |
|--------------------------|---|
| Wheels | Aluminium Wheels Machined Finish (12.8kg / Wheel) |
| Wheels | Aluminium Wheels Polished Finish (12.8kg / Wheel) |
| Tyres | Extra spare Tyre and Steel wheel |
| Tyres | Specific branded tyres. (Please State) |
| Ramps | Double Fold Ramps 3700mm x 900mm |
| Greasing | Central greasing with timer |
| Ship Locks | Twist locks to suit 1 x 40'0" - 1 x 20'0" container |
| Power Pack | 5.5HP Petrol Power pack 2000PSI mounted under gooseneck Bottom deck |
| Power Pack | 5.5HP Diesel Power pack 2000PSI mounted under gooseneck Bottom deck |
| Electrical | Air, Electrical lead and Hydraulic Hose |
| Storage | Toolbox fitted |
| Water Tank | Plastic Water Tank fitted |
| Yard Release | Yard release Dual system |

3 AXLE DROP DECK FLOAT

The 3 Axle Drop Deck Float is built for transporting larger heavy equipment with a high GVW. This is a low maintenance trailer with air bag suspension, optional plywood decks and hydraulics that run off the truck. Customisable options are available.

DRAWINGS

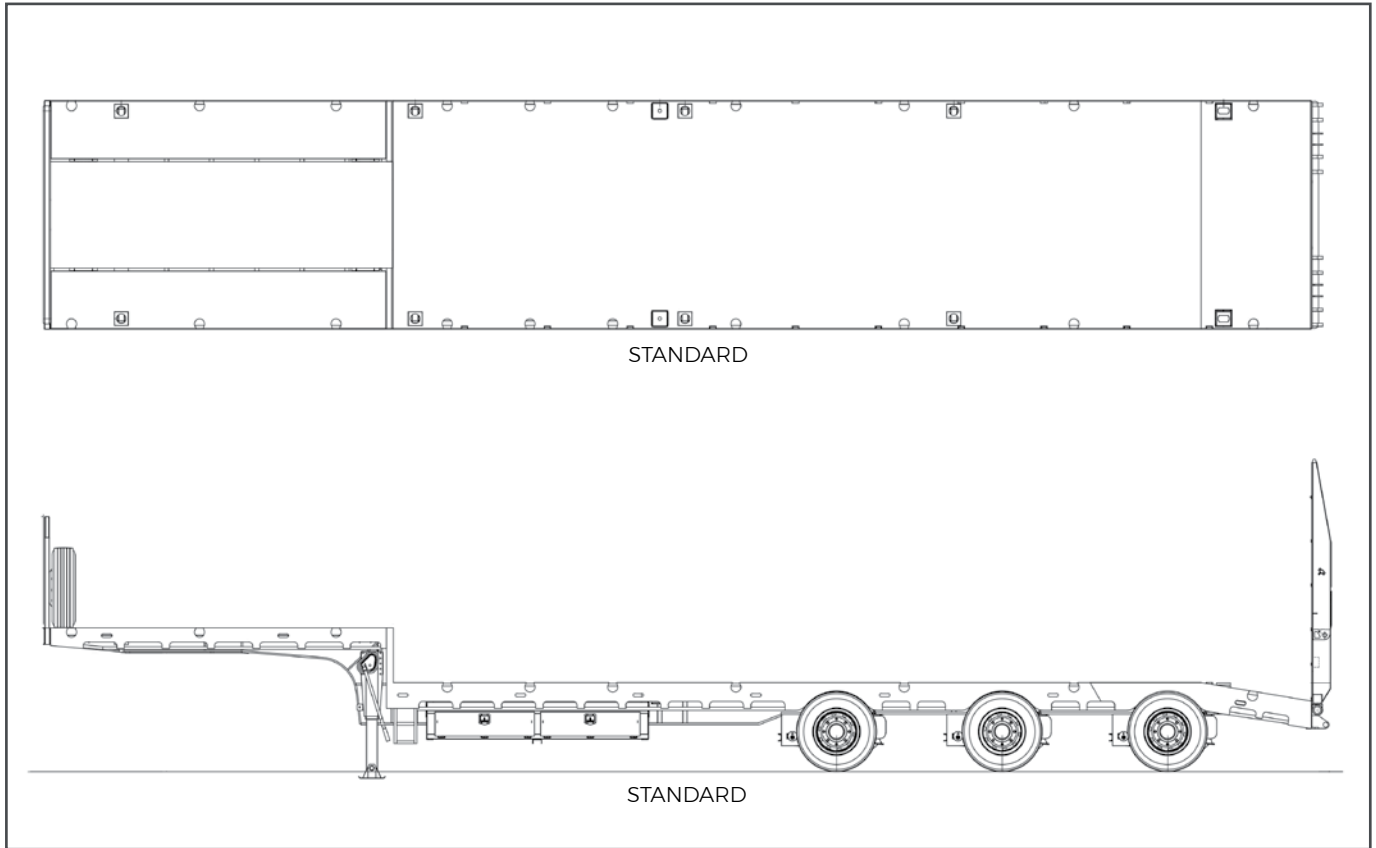

SPECIFICATIONS

| STANDARD SPECIFICATIONS (APPROX) | |
|----------------------------------|---|
| Width | 2490mm |
| Deck Height | 950mm |
| Axles | MTE 19.5" Axles |
| Axle Spacing | 1300mm - 1300mm |
| Suspension | Air Suspension |
| Brakes | ADR Brakes |
| Hydraulics | All lines to have removable couplings |
| Tyres | 265 x 19.5 |
| Wheels | Steel Wheels |
| Lighting | LED Lights in rear bumper and ramps & flashing beacon |
| Toolboxes | 2 x tool boxes |
| Water Tank | Plastic water tank |
| Signage | Over size signs |
| Landing Legs | Heavy Duty landing legs |

SPECIFICATIONS

STANDARD SPECIFICATIONS (APPROX)

| | |
|-----------------|--------------------------------|
| Deck Material | 6mm plate deck |
| Tie Down Points | Tie down points on top of deck |

OPTIONAL EXTRAS

OPTIONAL EXTRAS (APPROX)

| | |
|------------|---|
| Wheels | Aluminium Wheels Machined Finish (12.8kg / Wheel) |
| Wheels | Aluminium Wheels Polished Finish (12.8kg / Wheel) |
| Tyres | Specific branded tyres. (Please State) |
| Tyres | Extra spare Tyre and Steel wheel |
| Ramps | Detachable Double fold Ramps |
| Ramps | Hydraulic Ramps 2700mm x 860mm |
| Ship Locks | 3 way container locks |
| Power Pack | Electric Power pack 12Volt |
| Power Pack | 5.5 HP Honda power pack |
| Ringfeder | 30 Tonne Ringfeder and Brakes |
| Gates | 15 - 2.0m x 1.5m gates |

3 AXLE DROP DECK EXTENDABLE FLOAT

The 3 Axle Drop Deck Float is built for transporting larger heavy equipment with a high GVW. This is a low maintenance trailer with extendable length, air bag suspension, optional plywood decks and hydraulics that run off the truck. Customisable options are available.

DRAWINGS

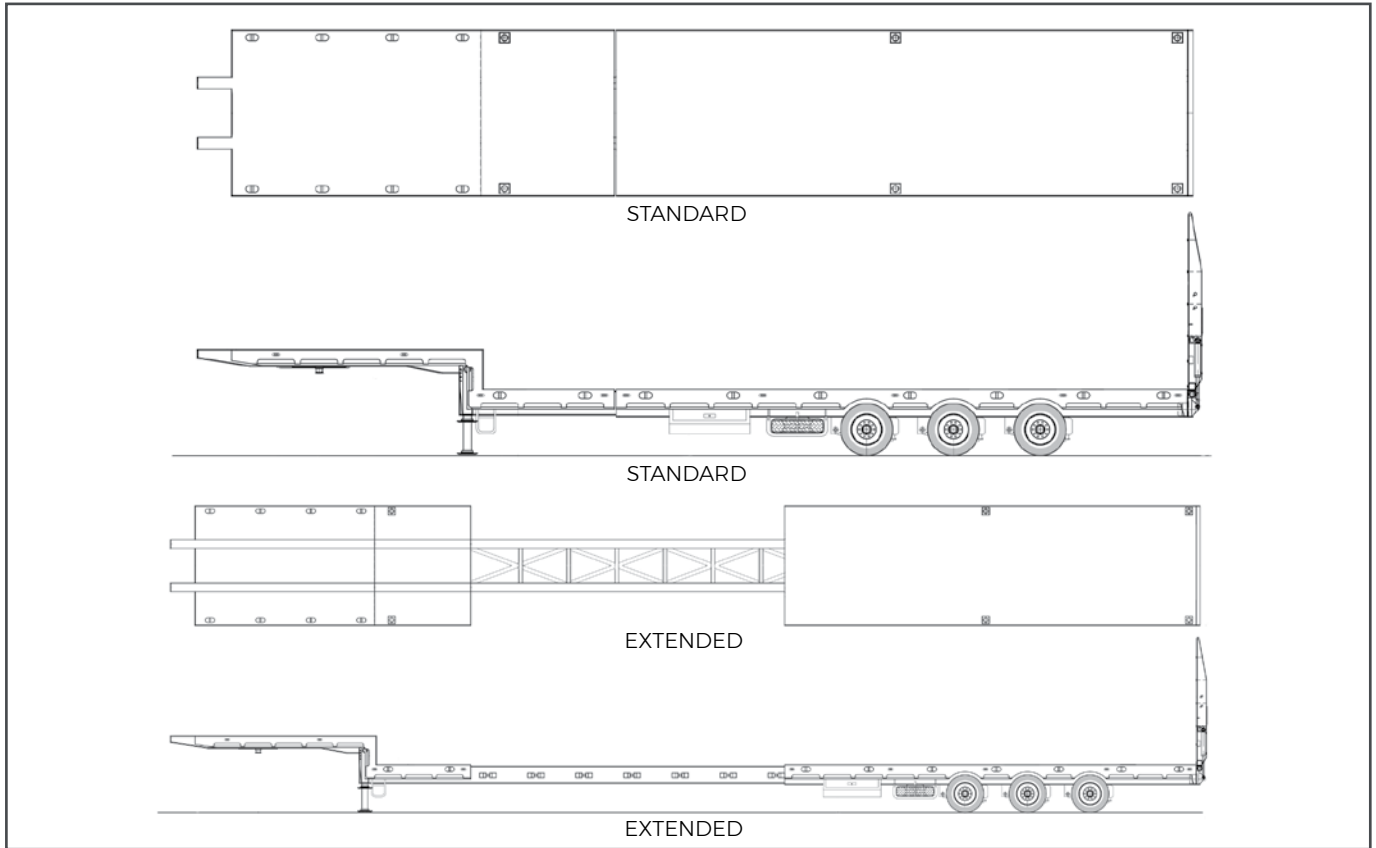

SPECIFICATIONS

| STANDARD SPECIFICATIONS (APPROX) | |
|----------------------------------|---|
| Width | 2490mm |
| Deck Height | 950mm |
| Axles | 15" Axles |
| Axle Spacing | 1250mm - 1250mm |
| Suspension | Air Suspension |
| Brakes | Outboard Drums 12-1/4" x 7-1/2" with Outboard Drums |
| Brakes | ADR with ABS Brakes |
| Hydraulics | All lines to have removable couplings |
| Tyres | 215 x 17.5 |
| Wheels | Steel Wheels |
| Lighting | LED & Lights in rear bumper & Beacon in ramps |
| Ringfeder | Ring feeder mount |
| Ramps | Hydraulic Ramps 2700mm x 860mm |
| Ramps | Ramps to top deck |
| Toolboxes | 2 x tool boxes |

SPECIFICATIONS

| STANDARD SPECIFICATIONS (APPROX) | |
|----------------------------------|---|
| Signage | Over size signs |
| Landing Legs | Heavy Duty landing legs |
| Deck Material | 5mm plate deck |
| Tie Down Points | Tie down points on top of deck |
| Ship Locks | 3 way container locks (must suit 40' container on bottom deck) |

OPTIONAL EXTRAS

| OPTIONAL EXTRAS (APPROX) | |
|--------------------------|---|
| Wheels | Aluminium Wheels Machined Finish (12.8kg / Wheel) |
| Wheels | Aluminium Wheels Polished Finish (12.8kg / Wheel) |
| Tyres | Extra spare Tyre and Steel wheel |
| Tyres | Specific branded tyres. (Please State) |
| Ramps | Double fold Ramps |
| Ship Locks | 3 way container locks |
| Power Pack | Electric Power pack 12Volt |
| Power Pack | 5.5 HP Honda power pack |
| Gates | 15 - 2.0m x 1.5m gates |

3 AXLE TILT TRAILER

The 3 Axle Tilt Trailer is a versatile heavy transport trailer that is suitable for all freight tasks. Designed to be self-loading with the tilt deck it is the ideal recovery trailer solution.

DRAWINGS

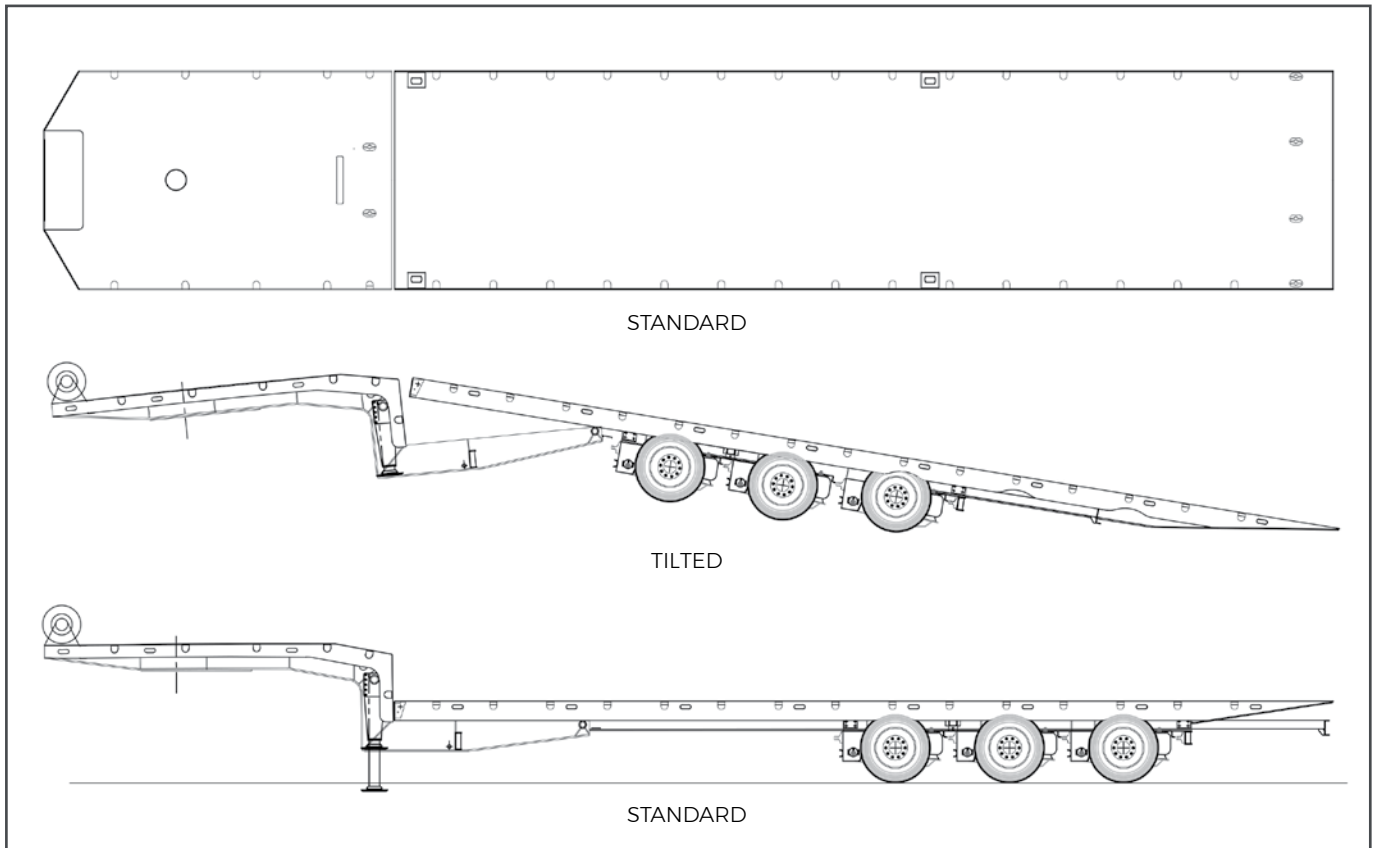

SPECIFICATIONS

| STANDARD SPECIFICATIONS (APPROX) | |
|----------------------------------|--|
| Width | 2490mm |
| Deck Height | 940mm |
| Axles | 17.5" |
| Axle Spacing | 1300mm - 1300mm |
| Suspension | Hendrickson Air Suspension |
| Brakes | 12-1/4" x 7-1/2" with Outboard Drums |
| Brakes | ADR |
| Hydraulics | Truck hydraulics |
| Hydraulics | All lines to have removable couplings |
| Tyres | 13 x 235 x 17.5 |
| Wheels | Steel Wheels |
| Lighting | Removable revolving light at rear |
| King Pin | 50mm and 90mm drop in king pin |
| Toolboxes | Two sliding tool boxes (one each side) |
| Signage | Oversize sign (Removable) |

SPECIFICATIONS

STANDARD SPECIFICATIONS (APPROX)

| | |
|---------------|---------------------|
| Landing Legs | Heavy Duty Pin Type |
| Deck Material | 5mm Plate |

OPTIONAL EXTRAS

OPTIONAL EXTRAS (APPROX)

| | |
|--------------------|--|
| Wheels | Aluminium Wheels Machined Finish (12.8kg / Wheel) |
| Wheels | Aluminium Wheels Polished Finish (12.8kg / Wheel) |
| Tyres | Extra spare Tyre and Steel wheel |
| Tyres | Specific branded tyres. (Please State) |
| Spare Tyre Carrier | Spare tyre carriers, on one side takes a 17.5 and the other side will take a 22.5 tyre (winch up type) |
| Remote Control | Remote control Hydraulics |
| Ship Locks | Twist locks 3 way |
| Water Tank | Plastic water tank |
| Winch | 30,000lb winch |

3 AXLE TILT SLIDE TRAILER

The 3 Axle Tilt Slide Trailer is a versatile heavy transport trailer that is suitable for all freight tasks. Designed to be self-loading with the sliding tilt deck it is the ideal recovery trailer solution.

DRAWINGS

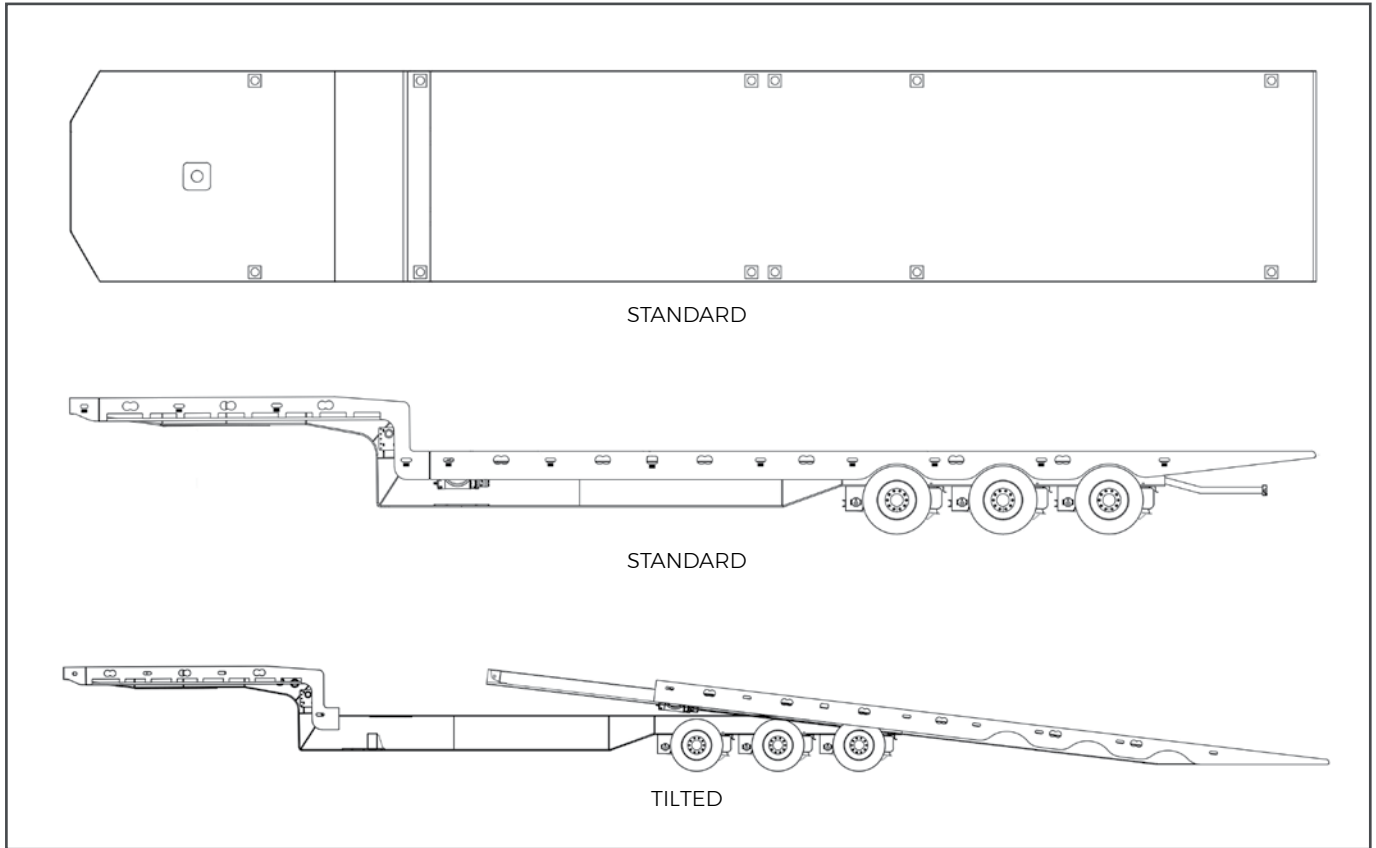

SPECIFICATIONS

STANDARD SPECIFICATIONS (APPROX)

| | |
|-----------------------|---|
| Length | 13716mm |
| Deck Length (Overall) | 10679mm |
| Axles | 15" 10 Stud |
| Suspension | Hendrickson air suspension with raise and lower valve |
| Brakes | 12-1/4" x 7-1/2" |
| Brakes | ADR ABS with bayonet fitting on front |
| Hydraulics | Rotary flow divider Fitted on gooseneck |
| Tyres | 215 x 70 x 17.5 |
| Wheels | Alloy |
| Spare Tyre Carriers | Single mounted on headboard |
| Lighting | LED Multi volt |
| Controls | Remote to tilt, slide and winch operations |
| Rub Plate | 8mm Rubplate |
| King Pin | 50mm |
| Toolboxes | 2 x toolboxes |

SPECIFICATIONS

| STANDARD SPECIFICATIONS (APPROX) | |
|----------------------------------|---|
| Landing Legs | Flat feet 2 speed K-Hitch |
| Deck Material | 6mm Hardox |
| Top Deck | 4mm Hardox |
| Tie Down Points | 14 x bottom deck 6 x top deck. |
| Rope rails: | 25mm full length top deck only |
| Ship Locks | 3 x way twist locks with storage for pedestals |
| Winches | 2 x 20,000lb ape stumpy hydraulic with 16mm cable and tensioners & free spool |

OPTIONAL EXTRAS

| OPTIONAL EXTRAS (APPROX) | |
|--------------------------|---|
| Wheels | Aluminium Wheels Machined Finish (12.8kg / Wheel) |
| Wheels | Aluminium Wheels Polished Finish (12.8kg / Wheel) |
| Tyres | Extra spare Tyre and Steel wheel |
| Tyres | Specific branded tyres. (Please State) |
| Remote Control | Remote control Hydraulics |
| Ship Locks | Twist locks 3 way |

3 ROWS OF 4 DROP-BED TRIPLE STEERABLE EXTENDABLE

The 3 rows of 4 Drop-bed Triple extendable is built for transporting long loads with a high GVW. This is a low maintenance trailer with air bag suspension and hydraulics running off the truck. Non-Drop bed and customisable options are also available.

DRAWINGS

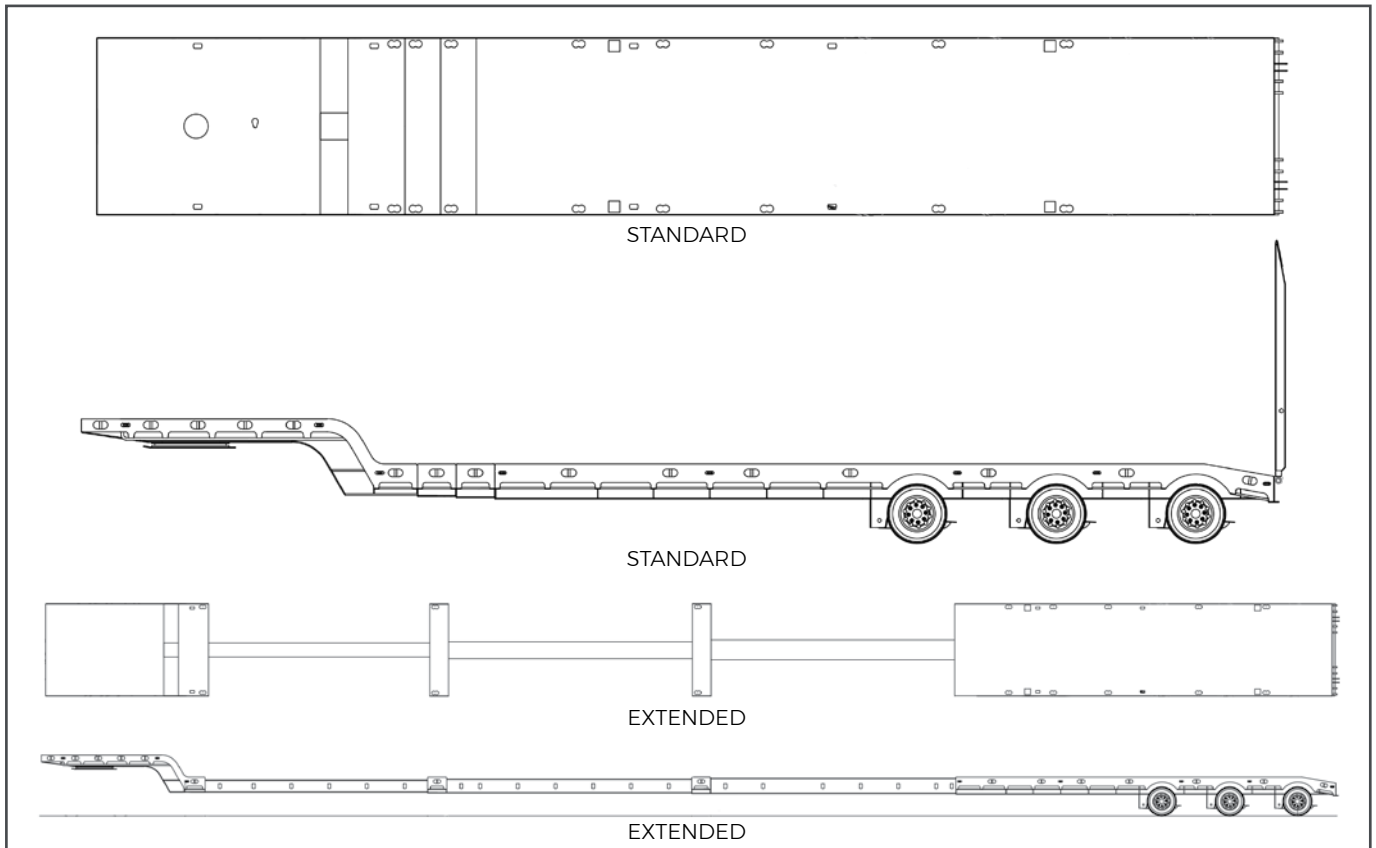

SPECIFICATIONS

| STANDARD SPECIFICATIONS (APPROX) | |
|----------------------------------|--|
| GVM | 40,000kg |
| Length | Max extended Length 33,000mm |
| Width | 2500mm |
| Deck Height | Max 900mm |
| Axles | 3 x 15" ten stud command |
| Suspension | Hendrickson Air |
| Brakes | Sealco |
| Hydraulics | Hydraulics Powered by Truck |
| Tyres | 12 x 215 x 17.5 |
| Wheels | Steel |
| Spare Tyre Carriers | Spare tyre carrier only Spare not supplied |
| Steering | Knuckle steer axles Manual operation |
| King Pin | 90mm |
| Landing Legs | K-Hitch full weight landing legs |
| Deck Material | Steel or timber deck |

OPTIONAL EXTRAS

| OPTIONAL EXTRAS (APPROX) | |
|--------------------------|---|
| Wheels | Aluminium Wheels Machined Finish (12.8kg / Wheel) |
| Wheels | Aluminium Wheels Polished Finish (12.8kg / Wheel) |
| Tyres | 235 x 17.5 tyres (in Lieu of 215 x 17.5) |
| Wheels carrier | Dual spare wheel carrier |
| Remote Control | Radio controls |
| Ship Locks | 12 Twist locks fitted |
| Suspension | Smallest spread sprung suspension 2500mm (Deduct) |
| Power Pack | 5 HP Diesel Power pack if required |
| Storage | Extra toolbox |
| Steering | Indexed Steering from the fifth wheel |
| Bolster | Sliding Bolster |
| Drop Bed | Drop Deck with Double fold ramps and beaver tail |

3 ROWS OF 4 STEERABLE TRIPLE EXTENDABLE

The 3 Rows of 4 Steerable Triple Extendable is built for transporting long loads with a high GWW. This is a low maintenance trailer with air bag suspension and hydraulics running off the truck. Customisable options are also available.

DRAWINGS

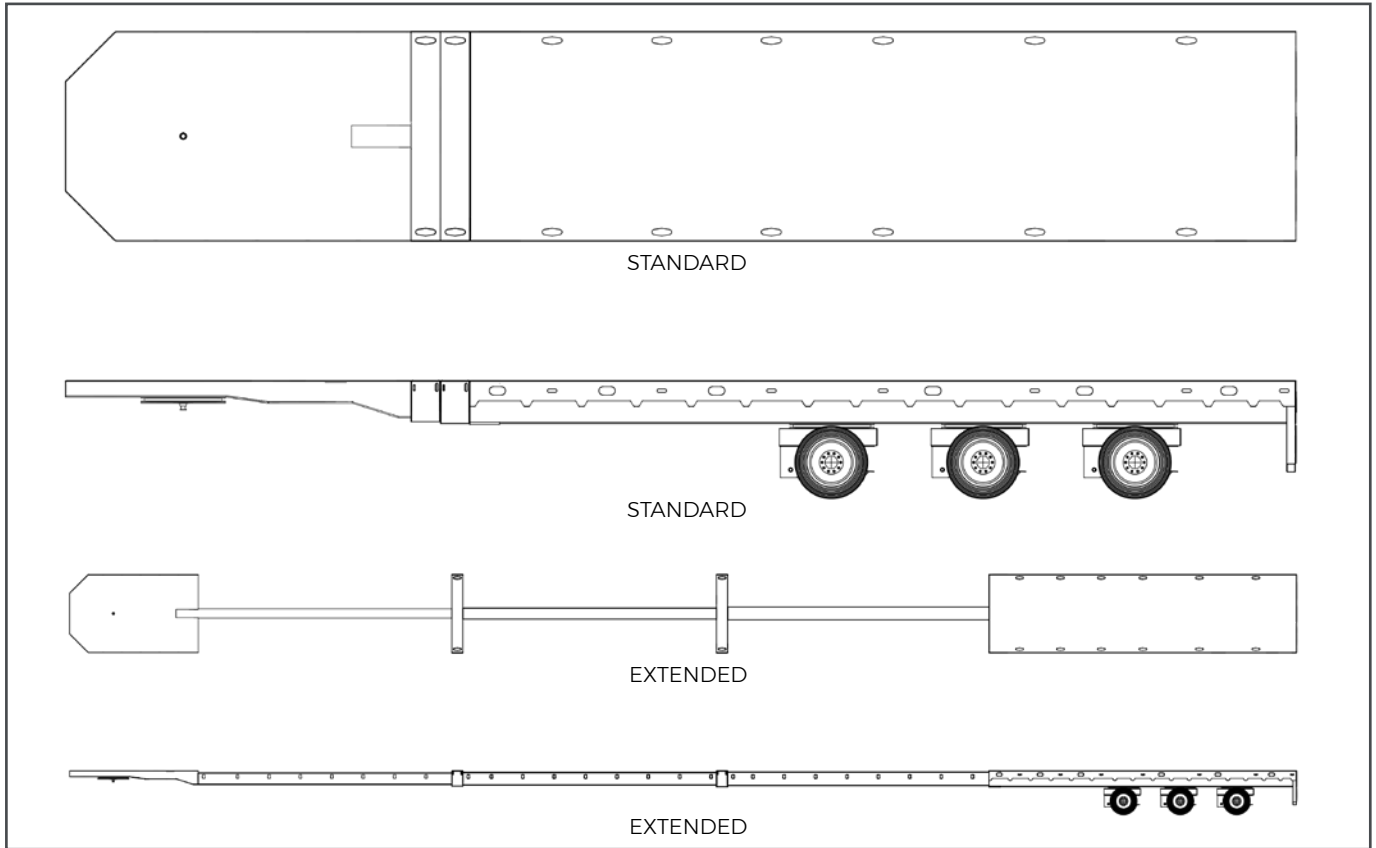

SPECIFICATIONS

| STANDARD SPECIFICATIONS (APPROX) | |
|----------------------------------|-------------------------------------|
| GVM | 40,000kg |
| Length | Max extended Length 38,000mm |
| Width | 2500mm |
| Deck Height | Max 1420mm |
| Axles | 3 x 19.5" Straight axles |
| Axle Spacing | 1800mm |
| Suspension | Hendrickson Air |
| Brakes | Sealco |
| Tyres | 12 x 265 x 19.5 tyres |
| Wheels | Steel Wheels |
| Controls | Remote Control |
| Steering / Towing | Ball race Manual steering operation |
| King Pin | 90mm |
| Toolboxes | x1 |
| Landing Legs | K-Hitch full weight landing legs |

OPTIONAL EXTRAS

| OPTIONAL EXTRAS (APPROX) | |
|--------------------------|---|
| Wheels | Aluminium Wheels Machined Finish (12.8kg / Wheel) |
| Wheels | Aluminium Wheels Polished Finish (12.8kg / Wheel) |
| Ship Locks | 4 Twist locks |
| Power Pack | 5.5HP Diesel Power pack if required |
| Storage | Extra Toolbox |
| Steering | Indexed Steering from the fifth wheel |

3 AXLE EXTENDABLE SEMI FLAT TOP TRAILER

The 3 Axle Extendable Semi Flat Top Trailer is built for transporting long loads with a high GVW. This is a low maintenance trailer with spring suspension and hydraulics running off the truck. Customisable options are also available.

DRAWINGS

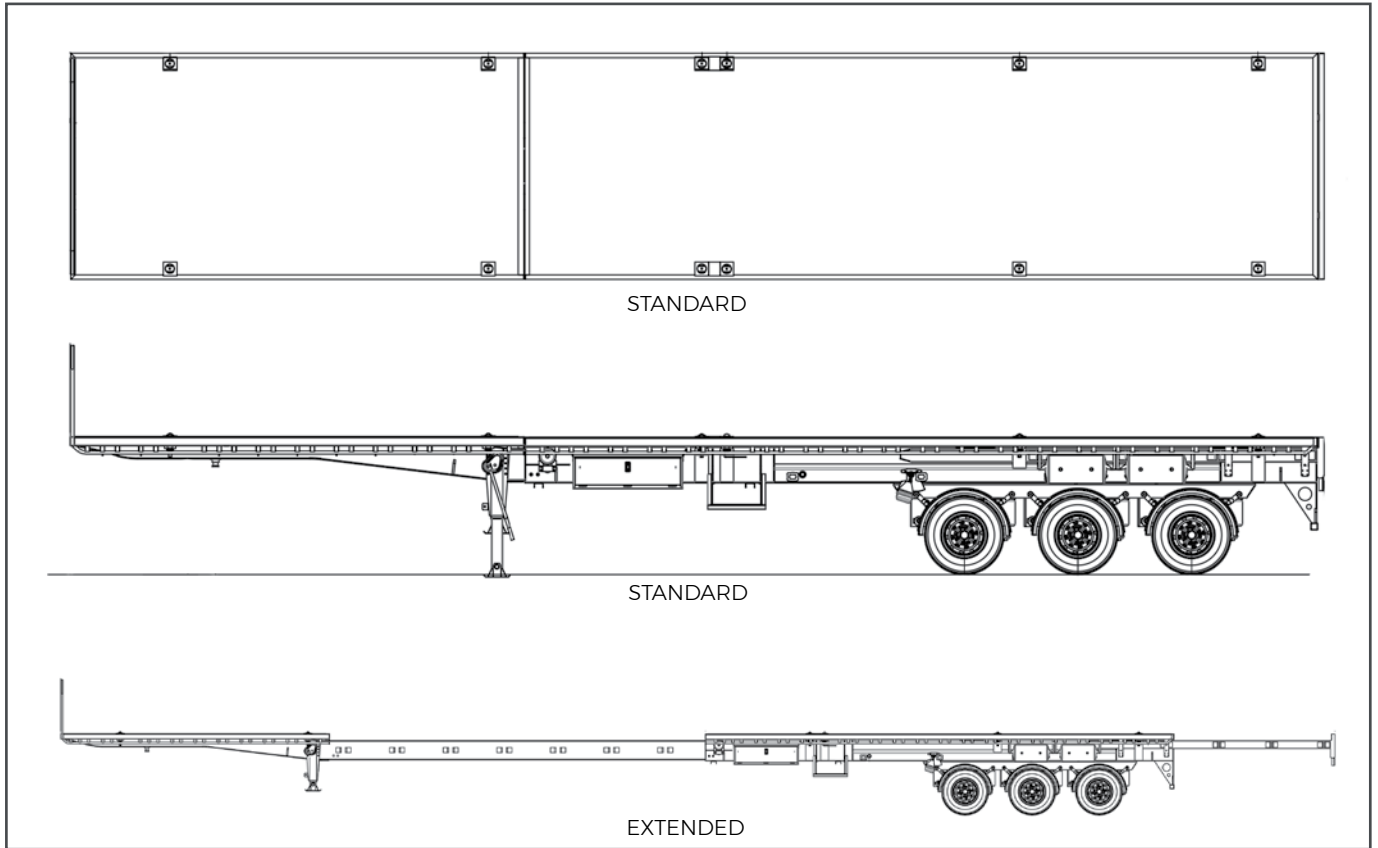

SPECIFICATIONS

| STANDARD SPECIFICATIONS (APPROX) | |
|----------------------------------|---|
| Length | 13730mm |
| Length (Extended) | 21950mm |
| Width | 2490mm |
| Axles | K-Hitch 20" Drum Brake axles with 22.5"x10 stud, 16½" x 7" S-Cam foundation brakes |
| Suspension | 9'-1" K-Hitch over slung spring suspension - 8 leaf springs |
| Brakes | ABS Westinghouse type with 30/30 spring brakes to all axles; all equipment complies with ADR regulations |
| Tyres | Twelve (12) Aeolus 11R22.5 |
| Wheels | Twelve (12) Steel wheels - 8.25 x 22.5 |
| Spare Tyre Carriers | One (1) off dual type |
| Electrical | 6mm moulded loom with 7 pin base at front, electrical loom to ADR 38 regulations. All lighting LED multi-volt |
| Rub Plate | Fixed high tensile fabricated plate with 90mm bolt in road train rated king pin - 2 pin position |
| Toolboxes | Two (2) only standard 1200 x 550 x 550 fitted with two (2) under box mounting straps bolted to frame |
| Bearer Box: | Fitted behind tri-axle suspension |
| Water Tank | One (1) 60 litre plastic |

SPECIFICATIONS

| STANDARD SPECIFICATIONS (APPROX) | |
|----------------------------------|---|
| Signage | Oversize, Road Train and rear revolving amber light |
| Landing Legs | K-Hitch 2 speed legs right hand side winding with compensating foot |
| Mud Guards | Plastic |
| Ship Locks | Six (6) rows of Twist locks to suit 1 x 40', 2 x 20' or 1 x 20' laden |
| Winches | Eleven (11) sliding winches in track |
| Gate Carrier | Provision only |
| Load Racks | Two (2) off pipe racks with pipe cross bars fitted between uprights |
| Frame Construction | Front and Rear Main Rail Sections are Fabricated Hi Tensile I Beams with Rollers Fitted at Junction of Pull out Section and Cradle Rollers at Tail End of Front Beam Section for easy sliding |
| Cross Members | RSJ section 102 x 45 fitted through plasma cut main rail webs |
| Coaming | 125 x 65 (5") RSJ style side coaming |
| Tie Rail | 25mm NB pipe with posts on end of each cross member |
| Front & Rear Bolster | Cast corners on pressed section, front bolster and RHS rear bolster with integral load rack pockets and 20mm NB pipe tie rails |
| Bumper | RHS verticals and RHS rear under run protection bar suitably supported and welded to rear under the main frame |
| Floor | 3mm steel chequer plate flooring supported by 30 x 30 RHS runners. Extra floor runners |

OPTIONAL EXTRAS

| OPTIONAL EXTRAS (APPROX) | |
|--------------------------|---|
| Wheels | Aluminium Wheels Machined Finish (12.8kg / Wheel) |
| Wheels | Aluminium Wheels Polished Finish (12.8kg / Wheel) |
| Tyres | Specific branded tyres. (Please State) |
| Tyres | Extra spare Tyre and Steel wheel |
| Railing | Gates and Headboard |
| Water Tank | Stainless Water tank and Tap |

6 AXLE B-TRAIN LOW LOADER

The 6 Axle B-Train Low Loader is one of our most popular trailers, Designed for transporting multiple plant or machines at one time, with increased manoeuvrability and stability over a standard low loader. Customisable with optional extras such as widening decks and key hole slots, the B-Train will carry any load.

DRAWINGS

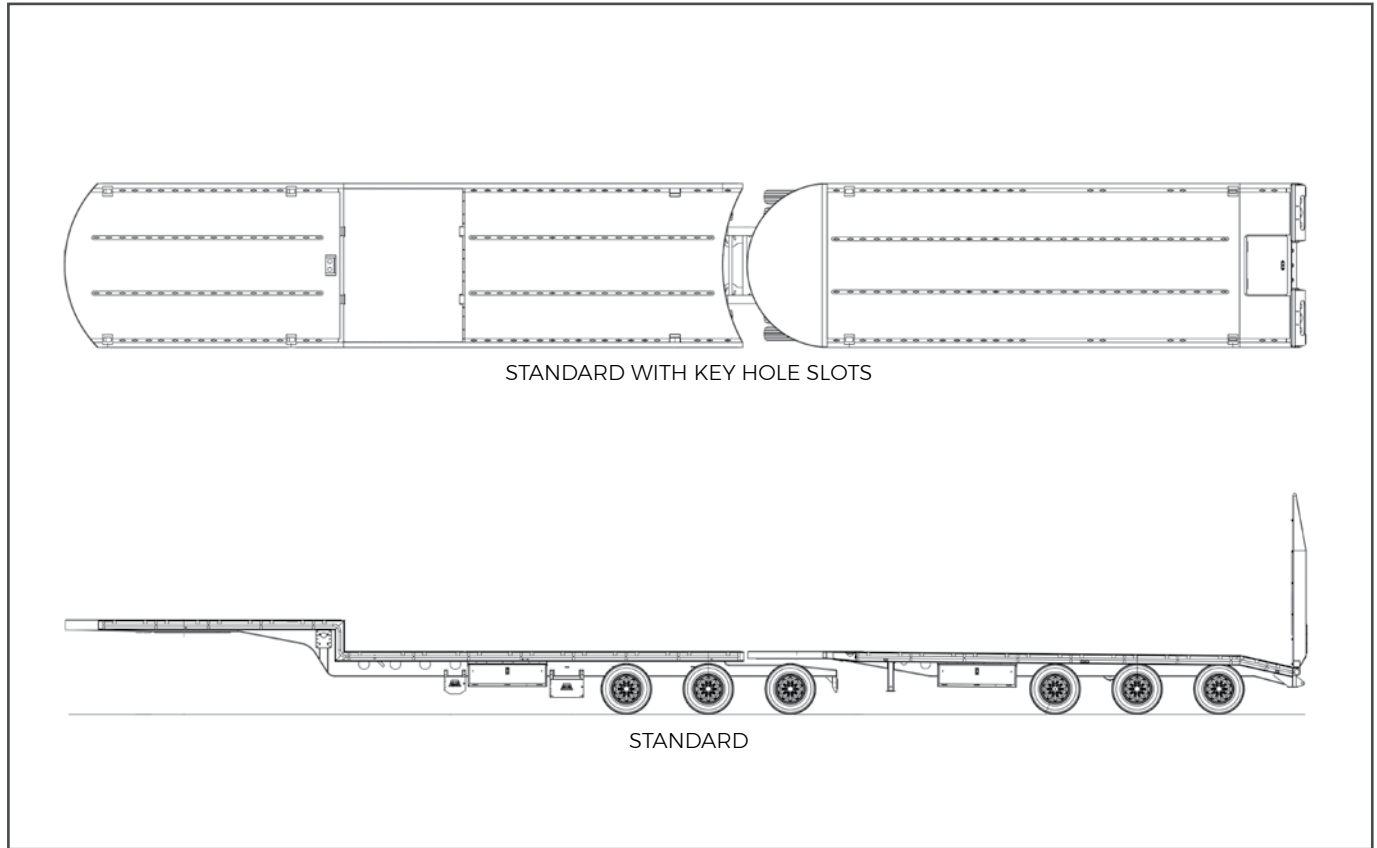

SPECIFICATIONS

| STANDARD SPECIFICATIONS (APPROX) | |
|----------------------------------|--|
| Length | 19300mm |
| Axles | 6 - 19.5" MTE outboard axles |
| Suspension | Air suspension with dump on rear unit |
| Brakes | EBS |
| Tyres | 19.5" tyres |
| Wheels | Steel wheels |
| Power Source | Truck Hydraulics |
| Lighting | Full LED Lights |
| Rub Plate | Fixed Rub Plate |
| 5th Wheel | 50mm sliding fifth wheel on front unit |
| King Pin | 50mm King Pin |
| Ramps | 2400mm x 680mm Hydraulic Ramps at rear |
| Toolboxes | 1x 900mm Lockable Toolbox with stainless lid |
| Dunnage Tray | 1x 2400mm Dunnage tray |
| Chain Bins | 1x Covered chain bin on rear beaver tail between ramps |

SPECIFICATIONS

| STANDARD SPECIFICATIONS (APPROX) | |
|----------------------------------|--|
| Deck Material | 300 x 50mm pine timber on outsides of deck |
| Deck Material | Steel Checker plate down center of decks & above wheels on rear unit |
| Tie Down Points | Rope Rail lashing under 100mm RSJ coaming (both units) |

OPTIONAL EXTRAS

| OPTIONAL EXTRAS (APPROX) | |
|--------------------------|--|
| Wheels | Aluminium Wheels Machined Finish (12.8kg / Wheel) |
| Wheels | Aluminium Wheels Polished Finish (12.8kg / Wheel) |
| Tyres | Spare tyre and steel wheel (28kg) |
| Ramps | Custom Ramps up to 2.7m Long |
| Ramps | Air operated pop-up ramps in front unit to top deck |
| Ship Locks | Ship lock Pockets for 2 x 20' containers. (Includes stools required for front unit). (8x Ship locks supplied) |
| Signage | Slide out chevrons with Lights, Front & Rear |
| Widening | Deck Widening Rear Unit |
| Railing | Custom Coaming Rails & Lashings |
| Keyhole Slots | Keyhole slots down both sides of decks |
| Power Pack | 5 HP Petrol power pack (Pull start) |
| Power Pack | 5 HP Petrol power pack (Electric start) |
| Power Pack | 12V Electric Power pack (Can be fitted inside a toolbox) |
| Storage | Extra Lockable 900mm Toolbox with stainless lid |
| Storage | Extra Dunnage Tray (2400mm) |
| Winch | 20,000lb Hydraulic Winch fitted with Remote |
| Restraint Gear | Load Restraint Kit: 8x 4.5m long 10mm transport chain, with clevis grab hooks at one end 8x Ratchet chain twitches 10x load binders 9m long, 2500kg rated |

3 AXLE SIMPLE TRAILER

Our smallest trailer available the simple trailer is exactly that, simple. They last forever and are extremely low maintenance. Perfect for transporting small excavators or for farm work. It can be configured with either 2 or 3 Axles with various deck lengths.

DRAWINGS

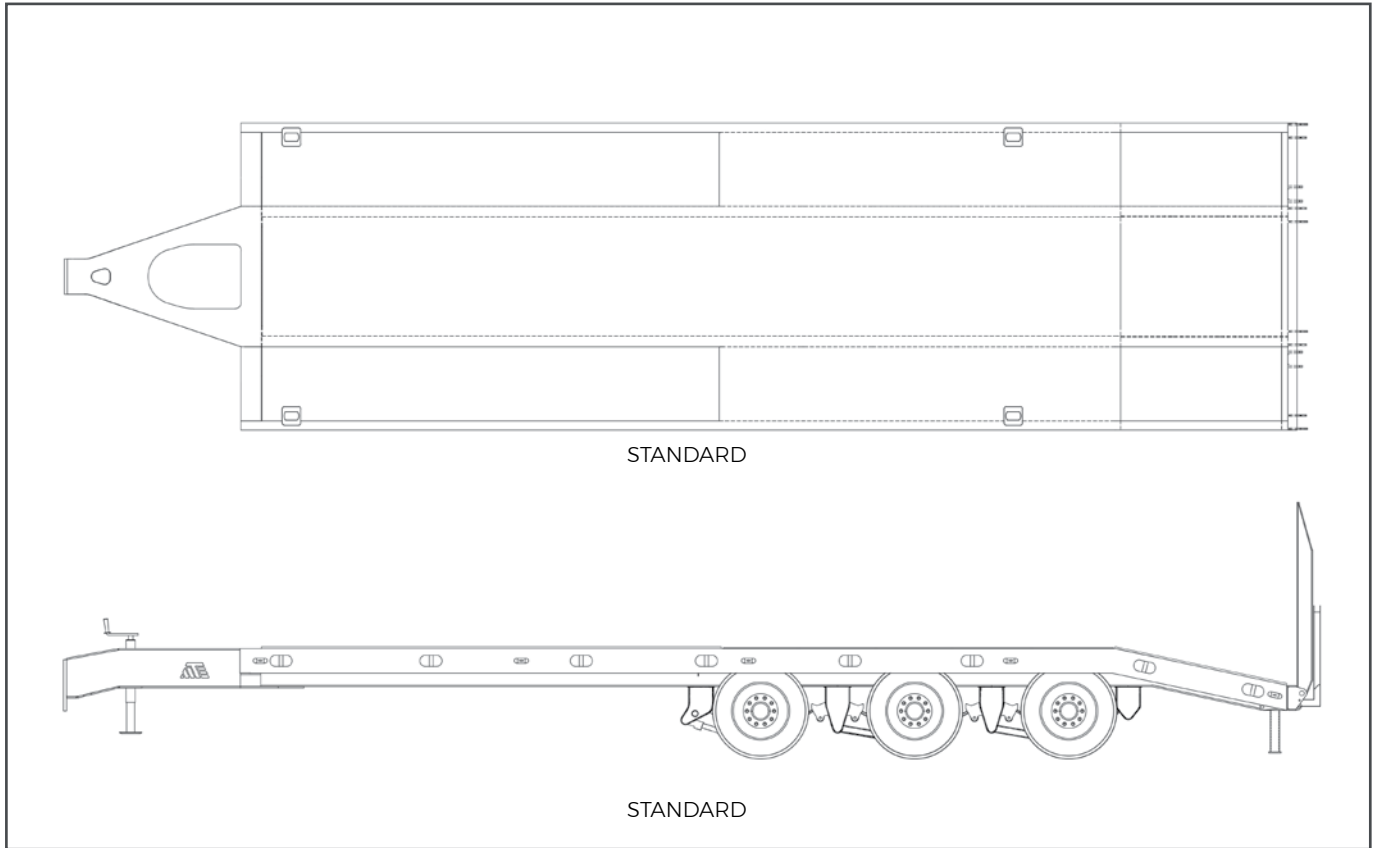

SPECIFICATIONS

| STANDARD SPECIFICATIONS (APPROX) | |
|----------------------------------|------------------------------------|
| Width | 2490mm |
| Deck Length (Overall) | 7500mm |
| Axles | 15" Ten Stud |
| Suspension | 3 leaf spring |
| Brakes | 12 1/4 x 7 1/2 with outboard drums |
| Brakes | ABS complies with new brake rule |
| Tyres | 215 x 17.5 |
| Wheels | Steel Wheels |
| Lighting | LED multi voltage |
| Drawbar | 5,000kg |
| Tow-eye | Pintle hook or 40mm tow-eye |
| Ramps | 1600 x 860 Hydraulic Ramps |
| Toolboxes | In drawbar |
| Deck Material | 6mm Cheka plate Deck |

OPTIONAL EXTRAS

| OPTIONAL EXTRAS (APPROX) | |
|--------------------------|---|
| Wheels | Aluminium Wheels Machined Finish (12.8kg / Wheel) |
| Wheels | Aluminium Wheels Polished Finish (12.8kg / Wheel) |
| Tyres | Specific branded tyres. (Please State) |
| Tyres | Extra spare Tyre and Steel wheel |
| Hydraulics | Hydraulic hand pump |

4 AXLE FLAT TOP LOW LOADER

The 4 Axle Flat Top Low Loader is a medium sized tow behind solution for transporting machinery, with a GVW of up to 29,000kg it is a versatile option for most jobs. Optional air suspension is available.

DRAWINGS

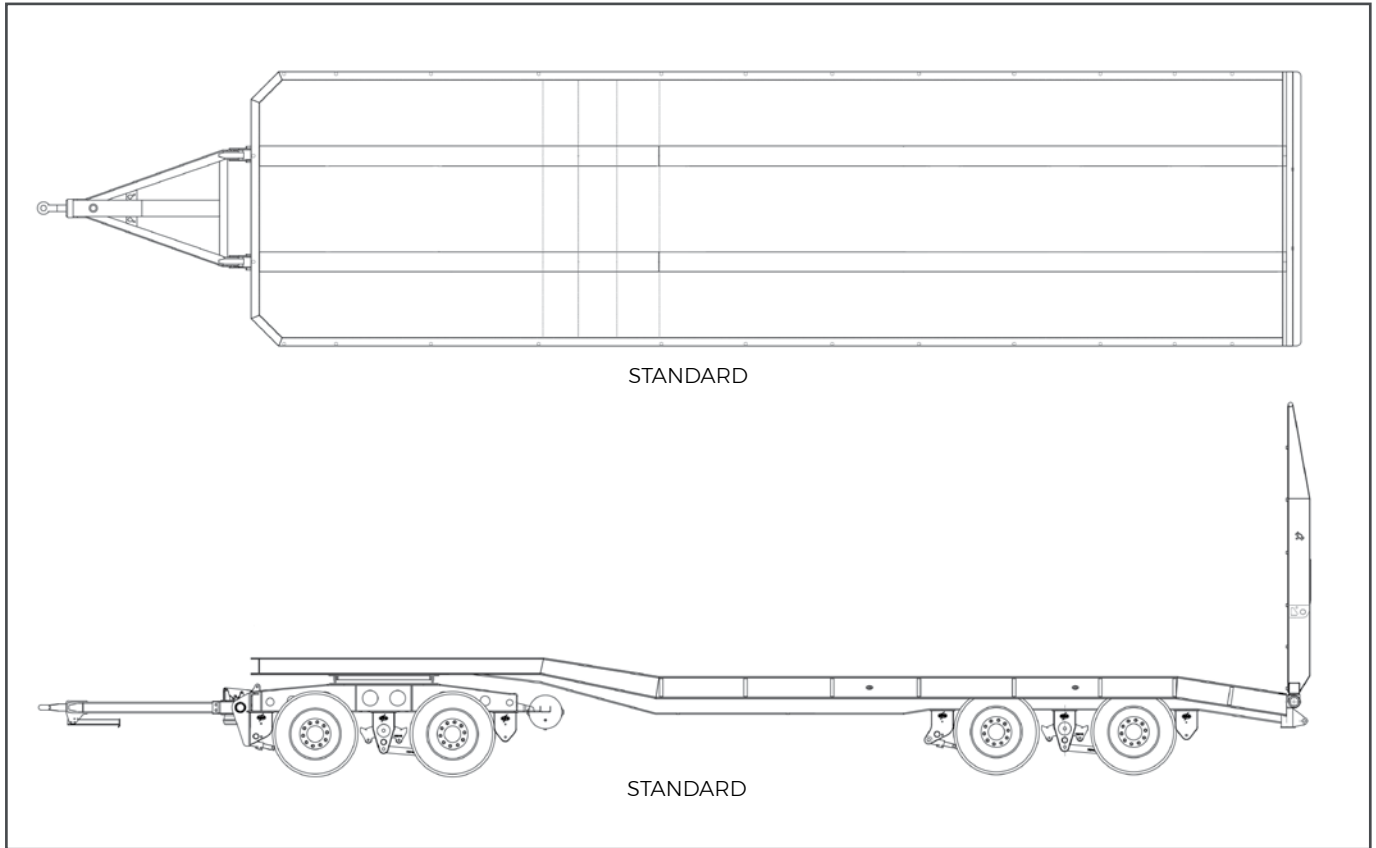

SPECIFICATIONS

| STANDARD SPECIFICATIONS (APPROX) | |
|----------------------------------|---|
| Length | 11500mm |
| Width | 2490mm |
| Axles | 15" Ten stud Axles |
| Suspension | 3 leaf suspension |
| Brakes | 12 1/4 x 7 1/2 brakes with outboard drums |
| Brakes | Sealco ABS |
| Tyres | 215 x 17.5 |
| Wheels | Steel Wheels |
| Lighting | LED |
| Tow eye | 50mm tow eye |
| Ramps | 2.7m x 860mm Hydraulic ramps |
| Toolboxes | Heavy Duty toolbox |
| Deck Material | 5mm Cheka plate deck |
| Mud Guards | Front guards and flaps on bogie |
| Tie Down Points | Certified lashing ties |

SPECIFICATIONS

STANDARD SPECIFICATIONS (APPROX)

| | |
|-----------------|--|
| Tie Down Points | 25mm NB Pipe tie rail under deck |
| Water tank | Plastic Water tank and soap dispenser fitted |

OPTIONAL EXTRAS

OPTIONAL EXTRAS (APPROX)

| | |
|------------|---|
| Wheels | Aluminium Wheels Machined Finish (12.8kg / Wheel) |
| Wheels | Aluminium Wheels Polished Finish (12.8kg / Wheel) |
| Tyres | Specific branded tyres. (Please State) |
| Tyres | Extra spare Tyre and Steel wheel |
| Suspension | Air Suspension |
| Storage | Tool box fitted |

5 AXLE FLAT TOP LOW LOADER

The 5 Axle Flat Top Low Loader is our largest tow behind solution for transporting machinery, with a GVW of 40,000kg it is a versatile option for most jobs. Optional air suspension is available.

DRAWINGS

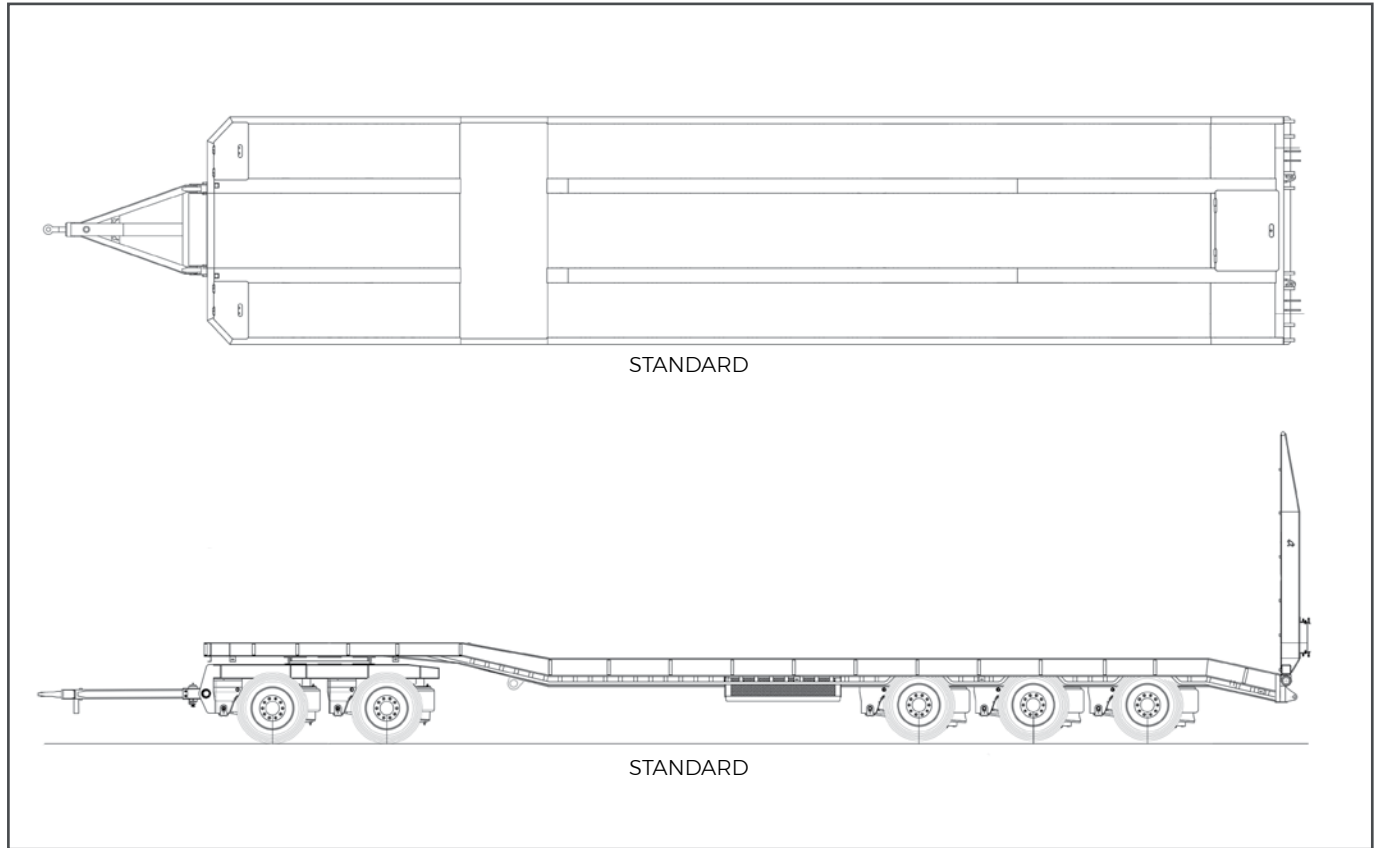

SPECIFICATIONS

STANDARD SPECIFICATIONS (APPROX)

| | |
|-----------------------|--|
| Width | 2490mm |
| Deck Length (Overall) | 12500mm |
| Axles | 15" Ten stud Axles |
| Suspension | 3 leaf suspension |
| Brakes | 12 1/4 x 7 1/2 brakes with outboard drums |
| Brakes | Sealco ABS |
| Tyres | 215 x 17.5 |
| Wheels | Steel Wheels |
| Power Source | 24 Volt power pack under deck LHS finished at front with 175 amp Anderson Plug |
| Lighting | LED |
| Tow Eye | 50mm tow eye |
| Ramps | 2.7m x 860mm Hydraulic ramps |
| Toolboxes | Heavy Duty toolbox |
| Deck Material | 5mm Cheka plate deck |
| Mud Guards | Front guards and flaps on bogie |

SPECIFICATIONS

| STANDARD SPECIFICATIONS (APPROX) | |
|----------------------------------|--|
| Tie Down Points | Certified lashing ties |
| Tie Down Points | 25mm NB Pipe tie rail under deck |
| Water Tank | Plastic Water tank and soap dispenser fitted |

OPTIONAL EXTRAS

| OPTIONAL EXTRAS (APPROX) | |
|--------------------------|---|
| Wheels | Aluminium Wheels Machined Finish (12.8kg / Wheel) |
| Wheels | Aluminium Wheels Polished Finish (12.8kg / Wheel) |
| Tyres | Specific branded tyres. (Please State) |
| Tyres | Extra spare Tyre and Steel wheel |
| Ramps | Double fold Ramps |
| Suspension | Air Suspension |
| Power Pack | 5HP Petrol Power Pack |
| Storage | Tool box fitted |

5 AXLE DECK WIDENING FLAT TOP LOW LOADER

The 5 Axle Deck Widening Flat Top Low Loader is our largest tow behind solution for transporting machinery, with a GVW of 40,000kg it is a versatile option for most jobs. From the outback to metro areas, the Deck Widener is a perfect transport solution for your needs. The Deck Widener features a fixed wheel track for optimal manoeuvrability around town and on site. Optional air suspension is available.

DRAWINGS

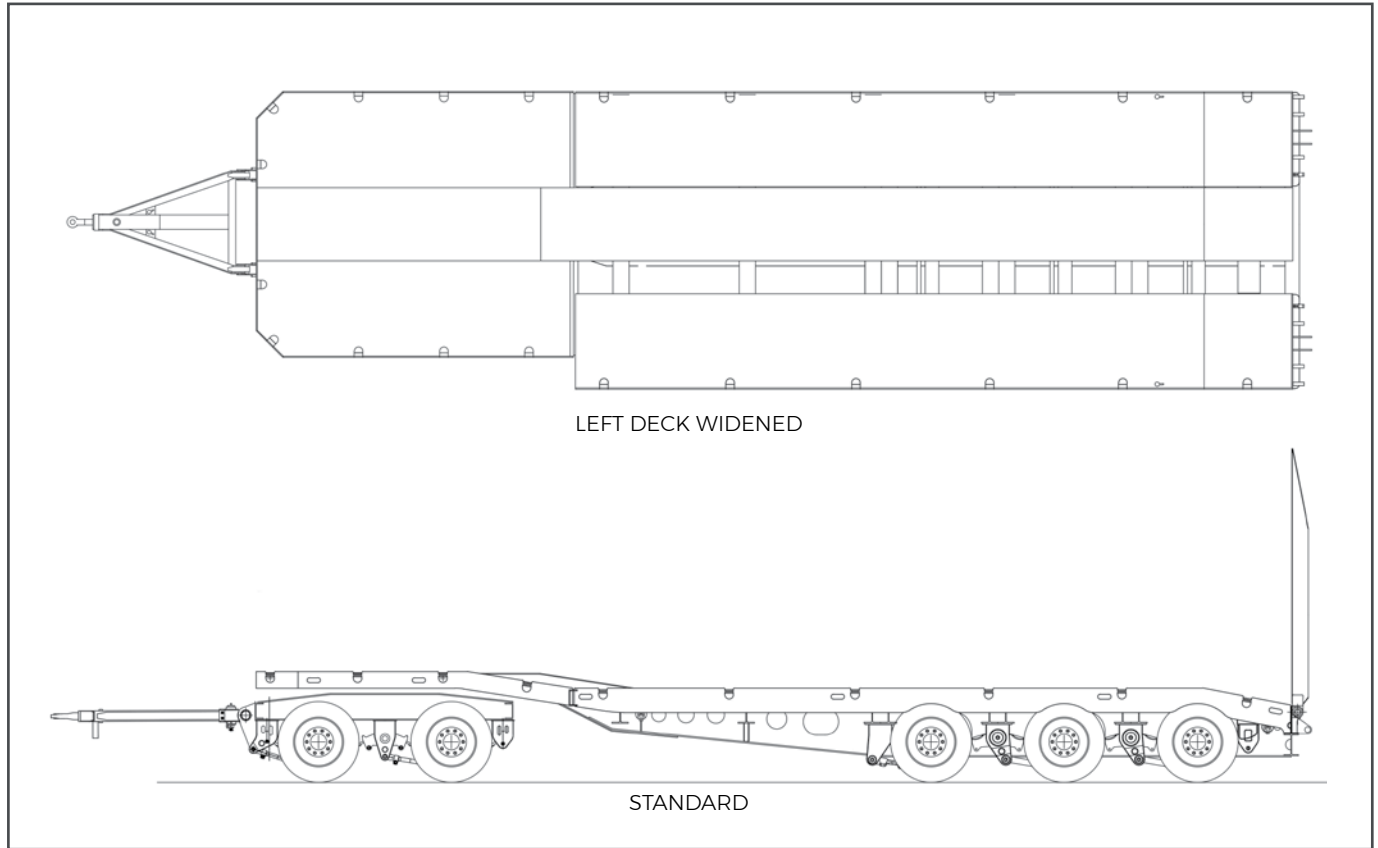

SPECIFICATIONS

STANDARD SPECIFICATIONS (APPROX)

| | |
|---------------|--|
| Length | 11500mm |
| Width | 2490mm |
| Widening | 2500mm - 3500mm (Bottom Deck Only) |
| Axles | 15" Ten stud Axles |
| Suspension | 3 leaf suspension |
| Brakes | 12 1/4 x 7 1/2 brakes with outboard drums |
| Brakes | Sealco ABS |
| Tyres | 215 x 17.5 |
| Wheels | Steel Wheels |
| Power Source | 24 Volt power pack under deck LHS finished at front with 175 amp Anderson Plug |
| Lighting | LED |
| Tow Eye | 40 or 50mm tow eye |
| Ramps | 2.7m x 860mm Hydraulic ramps |
| Toolboxes | Heavy Duty toolbox |
| Deck Material | 6mm Cheka plate deck |

SPECIFICATIONS

STANDARD SPECIFICATIONS

| | |
|-----------------|---------------------------------|
| Mud Guards | Front guards and flaps on bogie |
| Tie Down Points | Certified lashing ties |

OPTIONAL EXTRAS

OPTIONAL EXTRAS (APPROX)

| | |
|------------|---|
| Wheels | Aluminium Wheels Machined Finish (12.8kg / Wheel) |
| Wheels | Aluminium Wheels Polished Finish (12.8kg / Wheel) |
| Tyres | Specific branded tyres. (Please State) |
| Tyres | Extra spare Tyre and Steel wheel |
| Suspension | Air Suspension |
| Storage | Tool box fitted |
| Deck | Extra 1000mm deck length |
| Deck | Extra 2300mm deck length |

3 AXLE HARDOX SEMI TIPPER

The 3 Axle Hardox Semi Tipper is our standard tipper, Constructed out of Tough 5mm Hardox, the steel bin is built to transport loose materials of any kind. This tipper has full weight landing legs, ABS brakes & 3 leaf spring suspension as standard.

DRAWINGS

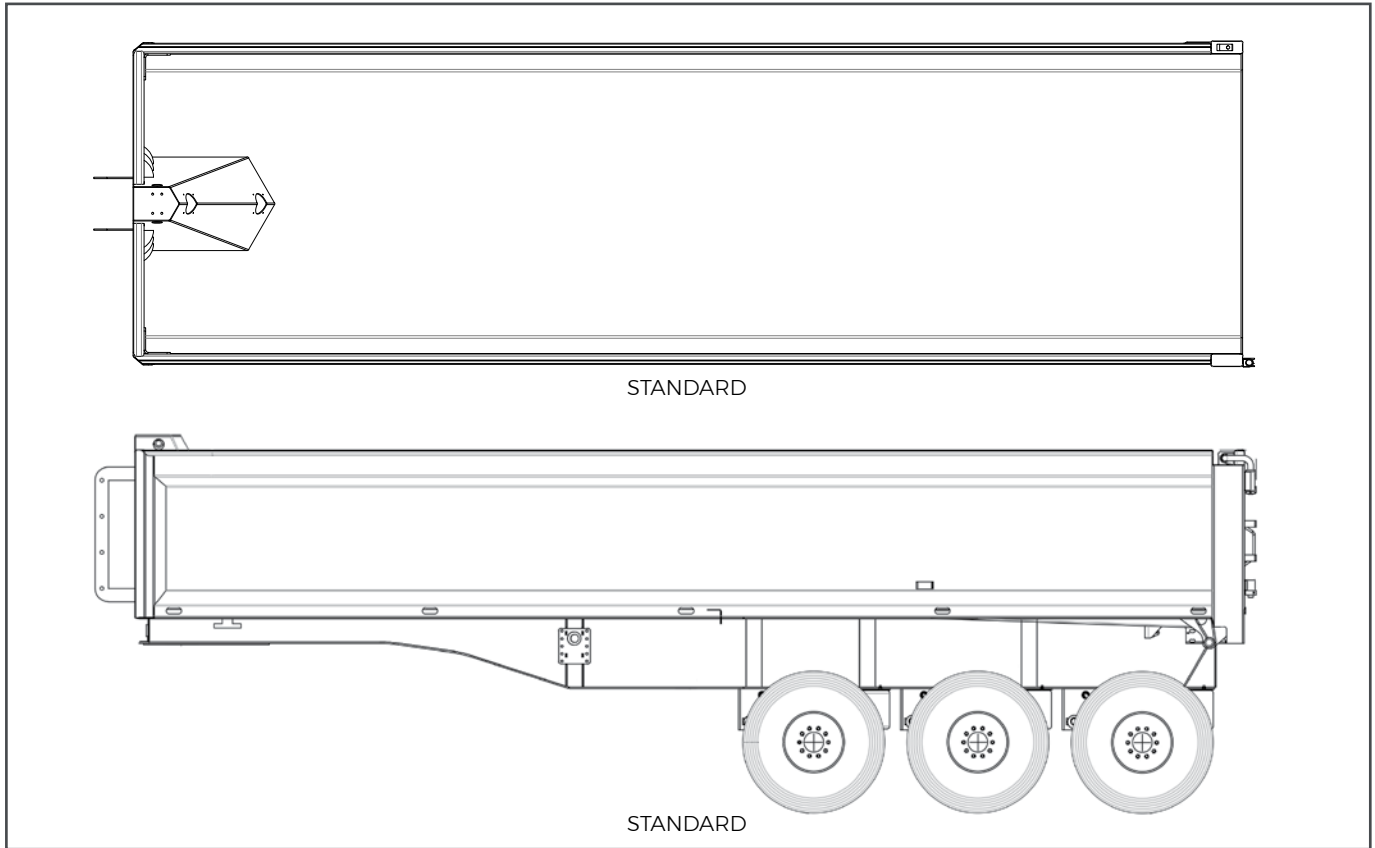

SPECIFICATIONS

| STANDARD SPECIFICATIONS (APPROX) | |
|----------------------------------|---|
| Length | 8534mm |
| Hardox Thickness | 5mm Hardox Floor and 4mm sides |
| Side Height | Side height 1200mm |
| Axles | 22.5" Ten stud Axles 16-1/2 x 7" Brakes |
| Suspension | 2500mm Tri 3 Leaf Suspension |
| Brakes | 22.5" Ten stud Axles 16-1/2 x 7" Brakes |
| Brakes | ABS |
| Hoist | 25 Tonne Delta hoist |
| Tyres | 15R 22.5 tyres on Alloy wheels |
| Spare Tyre Carriers | 1 Tyre Carrier |
| King Pin | 1-2" |
| Landing Legs | K-Hitch Full weight land legs |

OPTIONAL EXTRAS

| OPTIONAL EXTRAS (APPROX) | |
|--------------------------|---|
| Wheels | Aluminium Wheels Machined Finish (12.8kg / Wheel) |
| Wheels | Aluminium Wheels Polished Finish (12.8kg / Wheel) |
| Tyres | Extra spare Tyre and Steel wheel |
| Tyres | Specific branded tyres. (Please State) |
| Brakes | ABS Multi Volt Kit Fitted |

2 AXLE BOAT TRANSPORTER

The Axle Boat Transporter trailer is built to transport large boats upto 20,000kg. With vertical staunching sockets, the trailer can be adjusted to accomodate a large range boats.

DRAWINGS

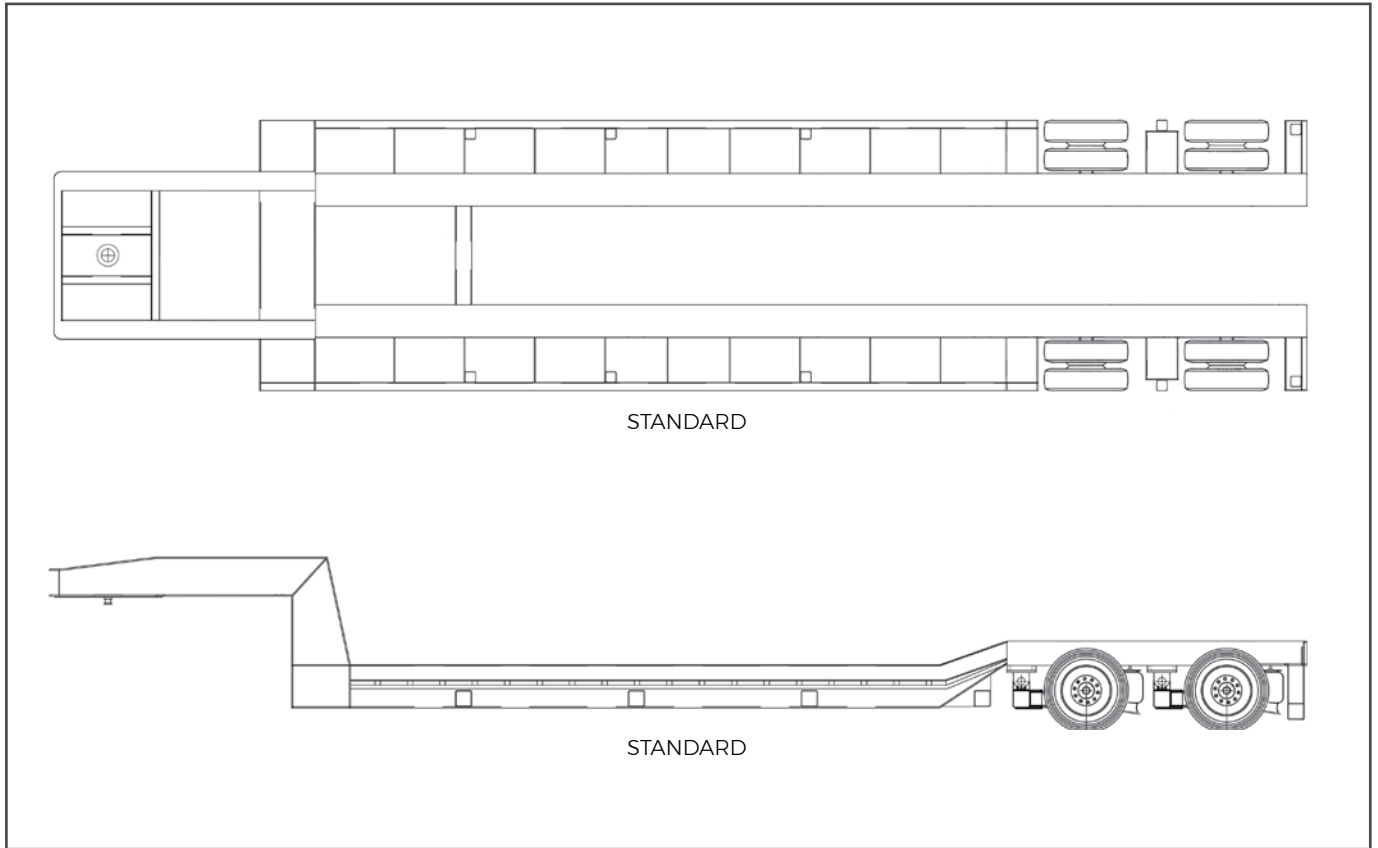

SPECIFICATIONS

| STANDARD SPECIFICATIONS (APPROX) | |
|----------------------------------|------------------------------------|
| Width | 2500mm wide across tyres max width |
| Forward Length | 9050mm |
| Axles | 15" MTE Ten Stud Axles |
| Suspension | Air Suspension |
| Suspension | Suspension travel 150mm |
| Brakes | 1/4" x 5-1/2" Brakes |
| Brakes | Brakes to ADR standards |
| Tyres | 8- 215 x 17.5 x 16 ply tyres |
| Wheels | Alloy Wheels |
| Lighting | LED lights |
| Rub Plate | Fixed Rub Plate |
| Rub Plate Height | 1250mm |
| King Pin | 2" King Pin |
| Landing Legs | 1- Landing leg pin type |
| Tie Down Points | Certified Lashing Ties |

SPECIFICATIONS

STANDARD SPECIFICATIONS

| | |
|---------|-----------------------------|
| Sockets | Vertical Staunching sockets |
|---------|-----------------------------|

OPTIONAL EXTRAS

OPTIONAL EXTRAS (APPROX)

| | |
|------------|---|
| Wheels | Aluminium Wheels Machined Finish (12.8kg / Wheel) |
| Wheels | Aluminium Wheels Polished Finish (12.8kg / Wheel) |
| Tyres | Extra spare Tyre and Steel wheel |
| Tyres | Specific branded tyres. (Please State) |
| Suspension | Hydraulic Suspension |
| Power Pack | 5 HP Petrol power Pack |
| Coating | Zinc spray |

3 ROW OF 4 PANEL TRAILER

The 3 Rows of 4 Hydraulic Suspension Panel trailer is built to transport concrete panels, the panel trailer is equipped with removable panel frames and hydraulic panel clamps.

The hydraulic panel clamps can extend to handle more pressure. An extendable option is available.

DRAWINGS

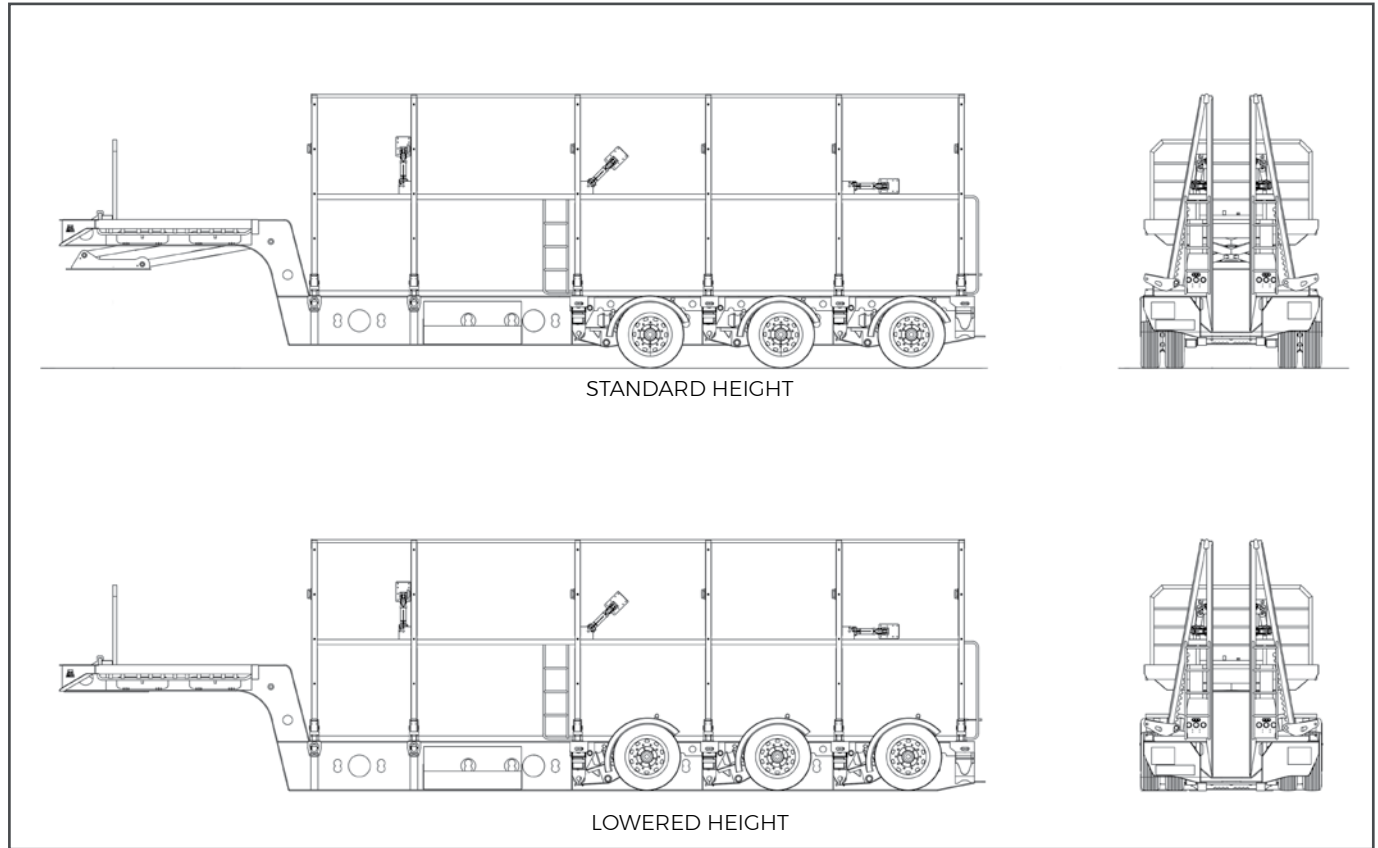

SPECIFICATIONS

| STANDARD SPECIFICATIONS (APPROX) | |
|----------------------------------|--|
| Width | 2500mm (Bottom Deck) |
| Deck Height | 900mm (Travelling) |
| Internal Deck Height | 250mm Fully Lowered |
| Forward Length | 9.5 metres |
| Overhang | 3.9 metres rear overhang (optional can be shorter) |
| Lift Height | 600mm (suspension and gooseneck) |
| Axles | MTE 19.5" Eight Stud Axles |
| Axle Spacing | 1600mm |
| Suspension | MTE Hydraulic Suspension, 10,000kg Capacity |
| Brakes | Full air brake to ADR |
| Tyres | 265 x 19.5" |
| Wheels | Steel Wheels |
| Lighting | Full LED |
| Turntable Height | Adjustable Turntable Height (1370mm std) |
| King Pin | 2" |

SPECIFICATIONS

STANDARD SPECIFICATIONS

| | |
|-----------------|--|
| Landing Legs | Full weight landing legs Heavy duty RHS type |
| Tie Down Points | Certified lashing ties |

OPTIONAL EXTRAS

OPTIONAL EXTRAS (APPROX)

| | |
|------------|---|
| Wheels | Aluminium Wheels Machined Finish (12.8kg / Wheel) |
| Wheels | Aluminium Wheels Polished Finish (12.8kg / Wheel) |
| Power Pack | 5 HP Petrol power Pack |
| Coating | Zinc |

3 AXLE HOUSE TRAILER

The Non-steer House Trailer is our basic house trailer. It is perfect for jobs that require a simple pick up or drop off at locations. It is less manoeuvrable than our other house trailers, but is more affordable.

Castor Steering or Command Steer options are available as optional extras.

DRAWINGS

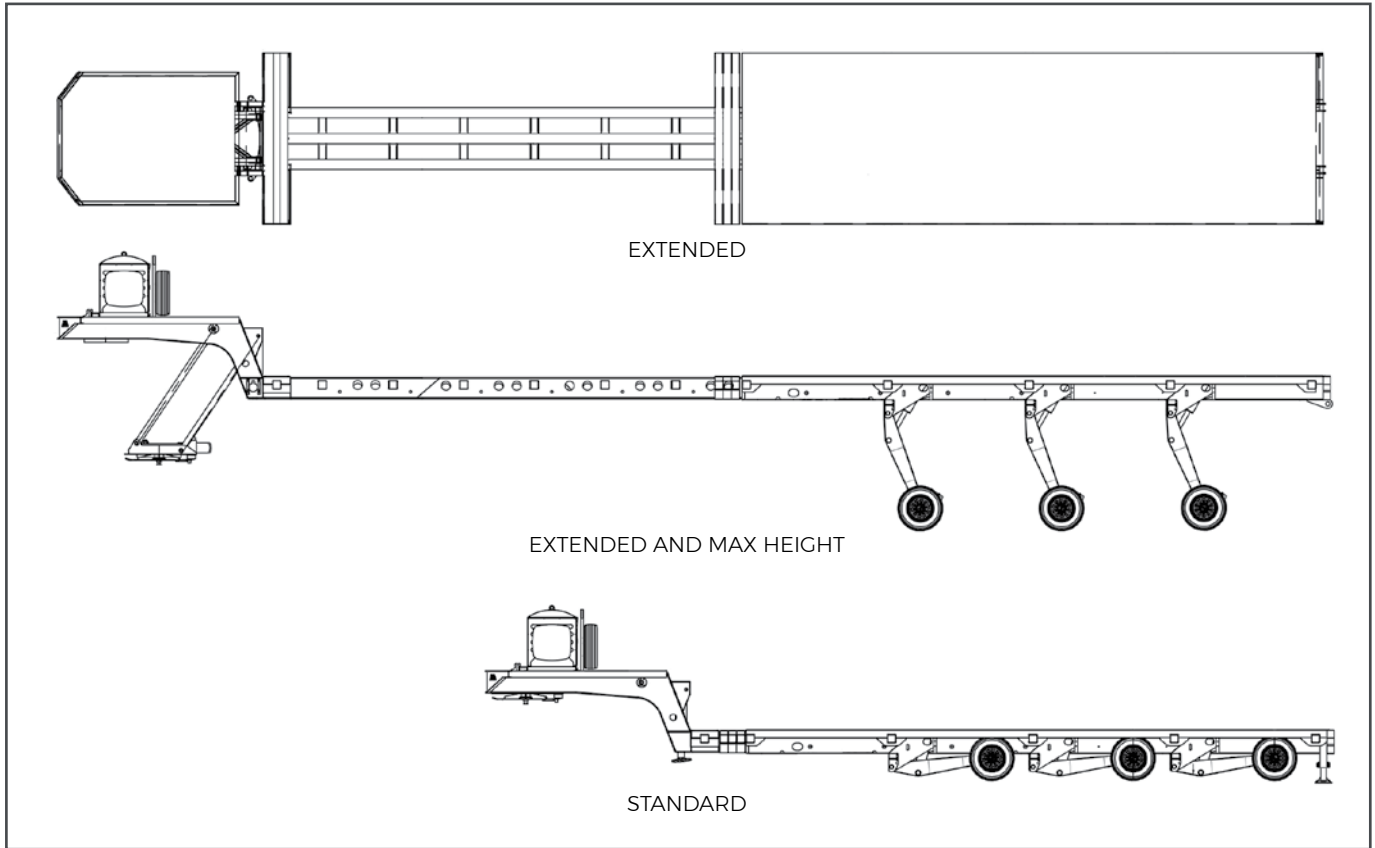

SPECIFICATIONS

| STANDARD SPECIFICATIONS (APPROX) | |
|----------------------------------|---|
| Deck Height Lowered | 880mm |
| Deck Height Raised | 2090mm |
| Deck Length Closed | 10,650mm |
| Deck Length Open | 18,000mm |
| Bottom Deck Width | 2500mm |
| Top Deck Width | 2500mm |
| Rear Overhang | 2860mm |
| Forward Length | 10,630mm |
| Axles | 17.5 Ten stud |
| Axle Spacing | 1830mm |
| Suspension | Suspension - Double acting single stage cylinders |
| Suspension | All suspensions have manual retraction locks (hydraulic valves) |
| Brakes | Outboard Drums |
| Hydraulics | Hydraulic controls on rub plate |
| Hydraulics | Operating pressure up to 3000 PSI |

SPECIFICATIONS

| STANDARD SPECIFICATIONS (APPROX) | |
|----------------------------------|---|
| Hydraulics | Single stage double acting front lift rams |
| Tyres | 235 x 17.5 |
| Wheels | Steel Wheels |
| Power Source | 14 HP diesel motor |
| Lighting | LED with 2x Rotating Beacons in rear |
| Electrical | Extension by a roll of hose includes brakes |
| Gooseneck | 14" Two Beam gooseneck with alloy tread plate on top deck |
| Deck Material | 4mm Chequer Plate outsides of Bottom Deck |
| Top Deck | Gates on Top Deck |
| Tie Down Points | Rope Rails |
| Sockets | Sockets to take 125 x 125mm RHS whiskers (not supplied) set 4" down |
| Sockets | Rear extension sockets |

OPTIONAL EXTRAS

| OPTIONAL EXTRAS (APPROX) | |
|--------------------------|---|
| Wheels | Aluminium Wheels Machined Finish (12.8kg / Wheel) |
| Wheels | Aluminium Wheels Polished Finish (12.8kg / Wheel) |
| Tyres | Specific branded tyres. (Please State) |
| Tyres | Extra spare Tyre and Steel wheel |
| Controls | 4 Proportional control valves |
| Controls | 4 Leaver 32 Channel Radio controller. (Proportional lifting) |
| Controls | 6 Proportional control valves. (3x lift, 3x steering) (one of steering valves for future clip-on) |
| Remote Controls | 6 Leaver Radio controller. (Proportional lifting & steering) (Motor start/stop switch, motor rev-up switch, 3x steering locks, 3x work light switches). |
| Signage | Sliding wing on front with pull out RHS. (maximum 3) |
| Steering | Rear axle castor steering |
| Extension | Rear extension bumper |
| Extension | 9,500mm Forward Length with 3690mm Rear Overhang (10,590mm Closed deck length) |
| Lighting | Light plugs on sides for house lights |
| Hydraulics | Front Hydraulic side shift |
| Hydraulics | Centre Hydraulic side shift |
| Hydraulics | Rear Hydraulic side shift |
| Hydraulics | Internal Track system for hoses |
| Tie Down Points | Pipe tie rail down side. 50 x 25mm RHS Droppers. (Certified 2,500kg per lashing) |

MTE JACKING PLANT - 12 OUTLETS

Standard 12 Outlet Jacking Plant, Designed to be used with MTE 2" or 3" Jacks

DRAWINGS

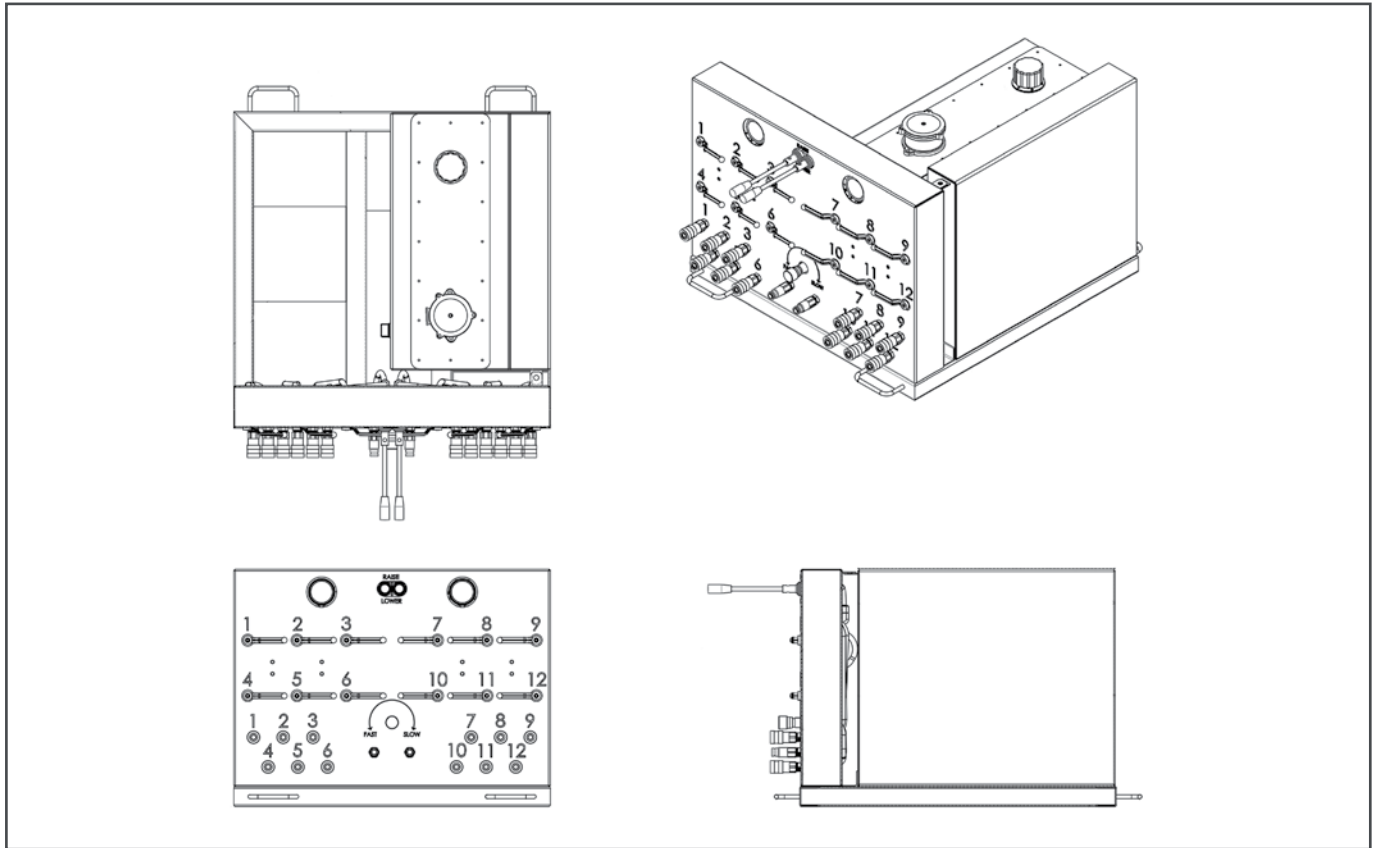

SPECIFICATIONS

| STANDARD SPECIFICATIONS (APPROX) | |
|----------------------------------|-------------------------------------|
| Motor | 13hp Electric start petrol engine |
| Outlets | 12 Outlets |
| Dimensions | 812mm x 711mm x 660mm |
| Pressure Monitors | Left & Right bank pressure monitors |
| Controls | 12 Outlet controls |
| Controls | 1 Unified controls |
| Hydraulics | 1 Pressure bleed of 2500 PSI |
| Hydraulics | Hydraulic tank and sight glass |
| Handles | Lifting handles front and rear |

OPTIONAL EXTRAS

| OPTIONAL EXTRAS | |
|-----------------|-----------------------------------|
| Jack | 2" Standard Jack with alloy cover |
| Jack | 3" Standard Jack with alloy cover |

MTE JACKING PLANT - 20 OUTLETS

Standard 12 Outlet Jacking Plant, Designed to be used with MTE 2" or 3" Jacks

DRAWINGS

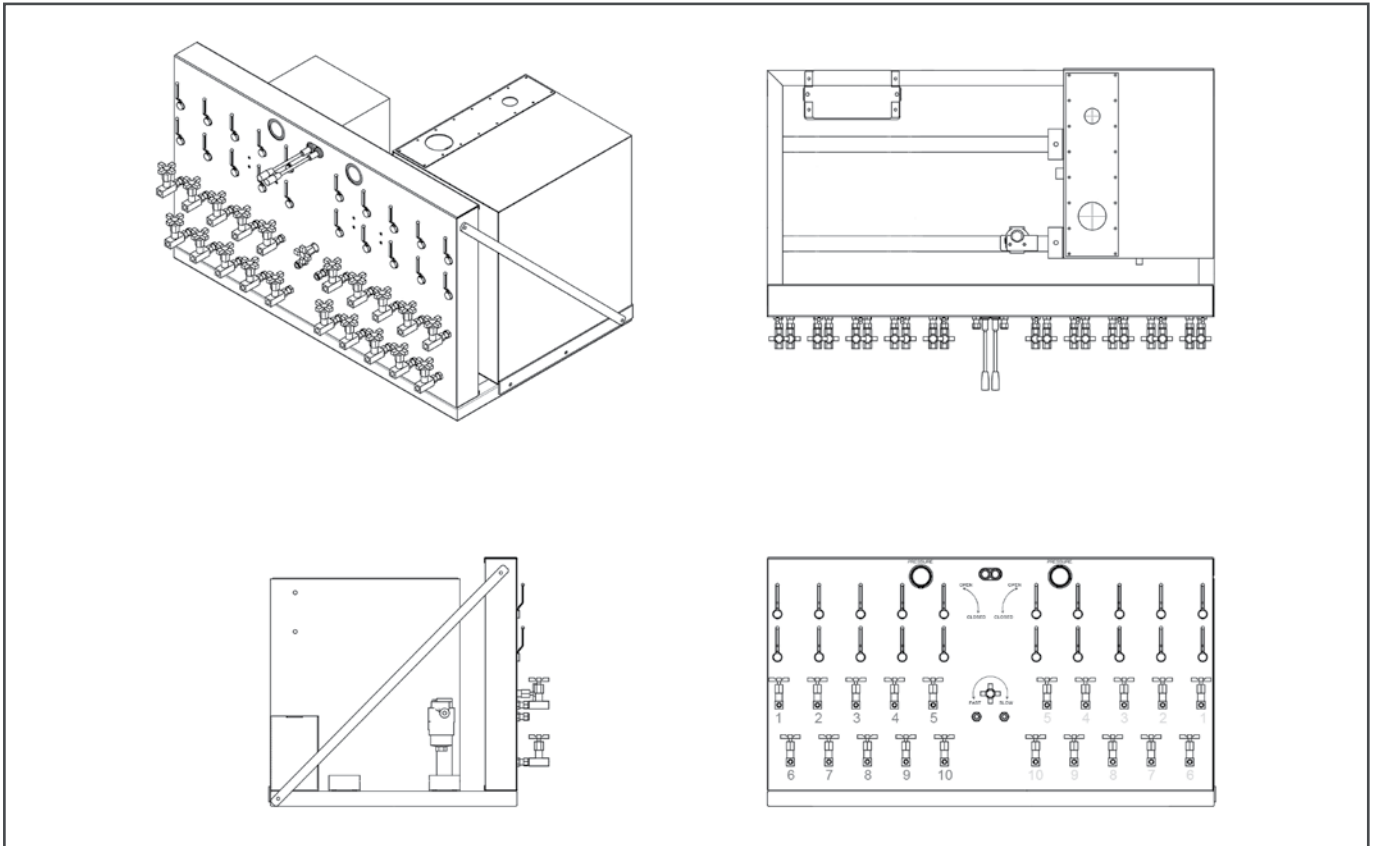

SPECIFICATIONS

| STANDARD SPECIFICATIONS (APPROX) | |
|----------------------------------|-------------------------------------|
| Motor | 18hp Electric start petrol engine |
| Outlets | 20 Outlets |
| Dimensions | 1066mm x 812mm x 762mm |
| Pressure Monitors | Left & Right bank pressure monitors |
| Controls | 20 Outlet controls |
| Controls | 1 Unified controls (each side) |
| Hydraulics | 1 Pressure bleed of 2500 PSI |
| Hydraulics | Hydraulic tank and sight glass |
| Handles | Lifting points on sides |

OPTIONAL EXTRAS

| OPTIONAL EXTRAS | |
|-----------------|-----------------------------------|
| Jack | 2" Standard Jack with alloy cover |
| Jack | 3" Standard Jack with alloy cover |

MTE STANDARD JACKS

Standard Jacks to be used with MTE Jacking Plants.

DRAWINGS

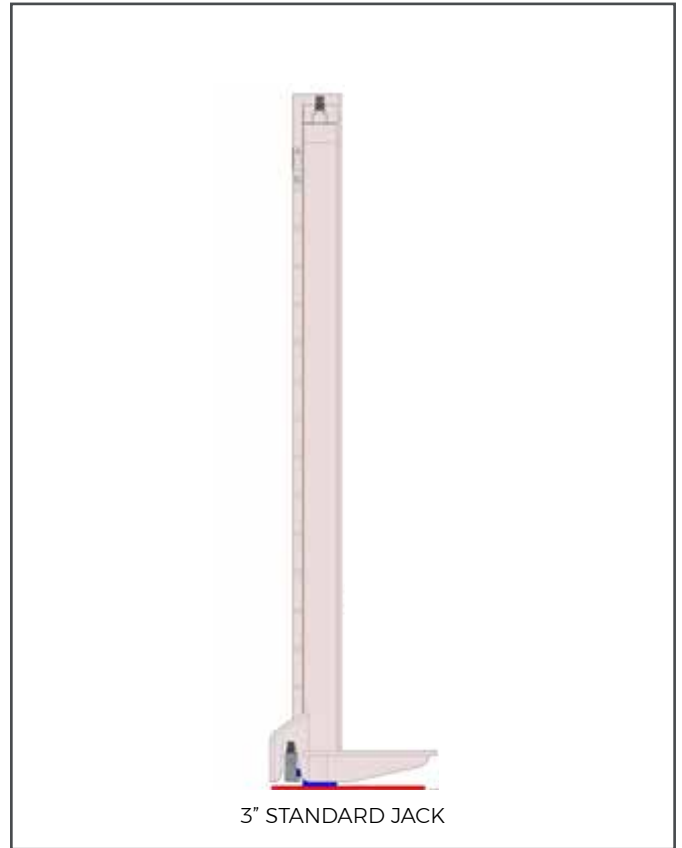
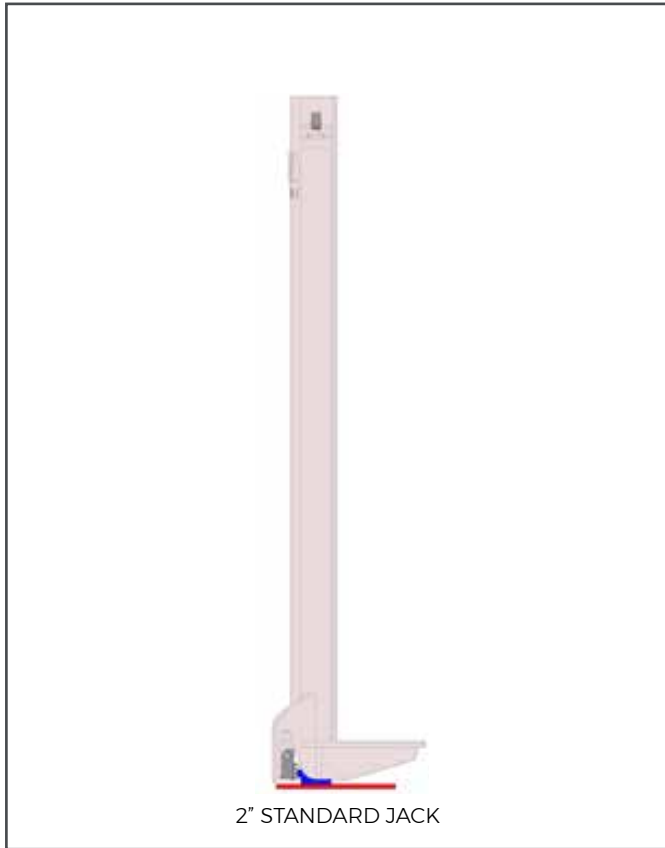

SPECIFICATIONS

| STANDARD SPECIFICATIONS (APPROX) | |
|----------------------------------|-------------------------------------|
| Model | MTE 2" Standard Jack |
| Internal Diameter | 2" ID |
| Stroke | 1350mm Stroke |
| Safe Working Load | 2000kg |
| Material | Aluminium High Tensile Outer Casing |
| Valves | Hold and Lowering valve for safety |
| Cylinder Type | Double acting |
| Operating Pressure | 2000 PSI |
| Weight | 45kg |

| STANDARD SPECIFICATIONS (APPROX) | |
|----------------------------------|-------------------------------------|
| Model | MTE 3" Standard Jack |
| Internal Diameter | 3" ID |
| Stroke | 1372mm Stroke |
| Safe Working Load | 5000kg |
| Material | Aluminium High Tensile Outer Casing |
| Valves | Hold and Lowering valve for safety |
| Cylinder Type | Double acting |
| Operating Pressure | 2000 PSI |
| Weight | 56kg |



MODERN TRANSPORT ENGINEERS

NZ - Visit www.modtrans.co.nz or call +64 7 849 4609
AUS - Visit www.modtrans.com.au or call +61 7 3393 5100

MTE AUSTRALIA IS A MEMBER OF THE MODERN TRANSPORT GROUP OF COMPANIES