



RIGHT
Laser Cut



WHERE EVERY CUT IS RIGHT

Laser Cutting

Precision in Every Cut

With our state-of-the-art Fiber Optic 3KW Laser, precision is our promise. From intricate designs to accurate shapes, we transform materials with laser precision. Your vision, perfectly cut.

TECHNICAL INFORMATION

Working length	6000mm
Working width	2500
Material thickness Max	20 mm

MATERIALS

MS & MSFP	Up to 20mm
SS & SSFP	Up to 10mm
Aluminium & ALFP	Up to 8mm
Brass	Up to 8mm
Copper	Up to 4mm
Titanium	Up to 2mm

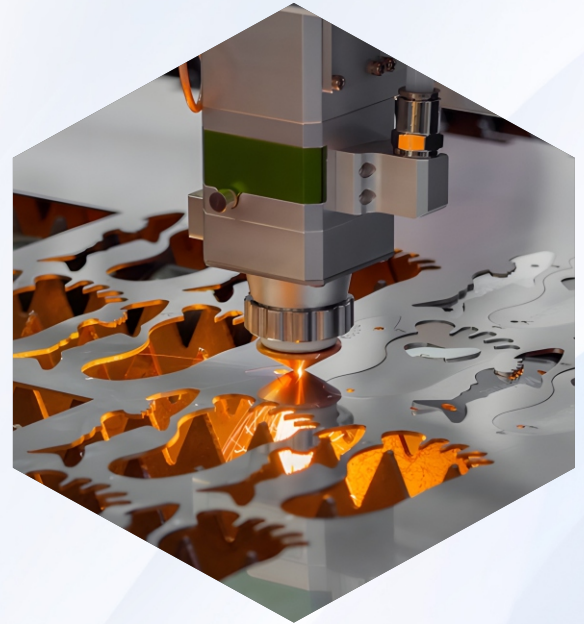

Pipe & Tube Cutting

Shape with Precision

Our expertise, backed by our advanced Fiber Optic 3KW Laser Machine, ensures exact cuts every time. Whether it's straight cuts or complex angles, we shape it to your specifications. Trust us for precision in piping.

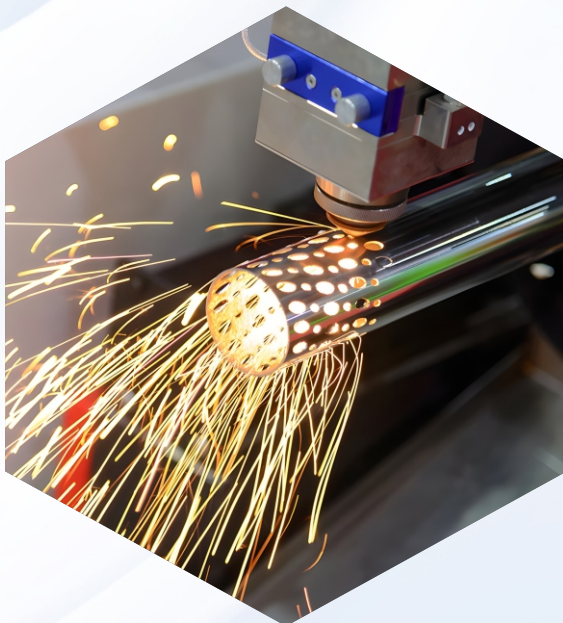

TECHNICAL INFORMATION

Working length	9000mm
Working width	350mm

LIST OF STRUCTURALS AND HOLDING CAPACITY OF THE MACHINE.

CHS	Upto 300 dia
RHS & SHS	Upto 300mm
UB (Universal Beam)	Upto 250UB 25
UC (Universal Column)	Upto 200UC 59
PFC - Channels	Upto 230x90
Equal & Unequal Angles	Upto 250mm

CNC Press brake machine.

Where the flat piece comes to life

Unlock precision bending capabilities with our 3 Axis CNC Press Brake Machine—combining accuracy, efficiency, and user-friendly operation for all your cutting needs. Plus, explore our rolling solutions for added versatility.

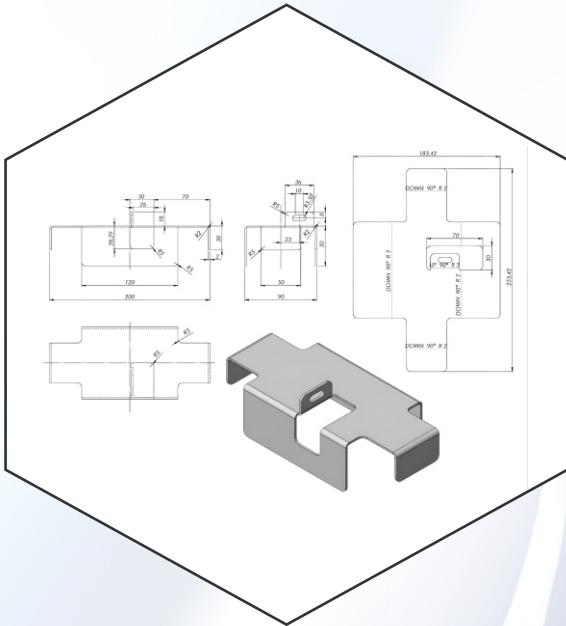

Designing

Turning Ideas into Reality

Start with a blueprint. Our experienced designers work with you to create detailed plans and 3D models. Visualize your project before production begins, ensuring it's just right.

Welding & Fabrication

Strong Connections, Durable Results

Our skilled welders create strong, durable connections for your metal components using advanced techniques like MIG and TIG welding. From custom structures to precise assemblies, we bring your designs to life with expert welding and fabrication craftsmanship.



Metal Coating

Finishing Excellence

Enhance and protect your metal components. Choose from powder coating or painting for a durable finish, or opt for zinc plating to resist corrosion. Beauty meets longevity.



Precision Machining Solutions

Drilling, Tapping, Milling, and Counter-Sinking

Prepare for assembly with precision. Our drilling, tapping, and countersinking services ensure accurate holes and threads. Countersunk holes provide a clean and secure fit. At Right Laser Cut, we combine the latest technology with expert craftsmanship to deliver top-quality results. PDA ensure your projects are in safe hands.



Contacts

📍 Building 2/101, Port Wake field Rd, Cavan, SA 5094

🌐 www.rightlaser.com.au

☎ 0472 738 480

✉ info@rightlaser.com.au

SRIKANTH CHINTALA
Managing Director

✉ sri@rightlaser.com.au

☎ 0420 707 272



RIGHT
Laser Cut

WHERE EVERY CUT IS RIGHT